

ATEX-II2DGcT6

ATEX Gearboxes

Planetary Gearheads



北京润诚时代科技有限公司

地址：北京市朝阳区汤立路218号A座 301室

电话：010-84450370

网址：www.runcheng.net

邮箱：runcheng_emd@sina.com



ENGINEERING YOUR SUCCESS.



WARNING – USER RESPONSIBILITY

FAILURE OR IMPROPER SELECTION OR IMPROPER USE OF THE PRODUCTS DESCRIBED HEREIN OR RELATED ITEMS CAN CAUSE DEATH, PERSONAL INJURY AND PROPERTY DAMAGE.

- This document and other information from Parker-Hannifin Corporation, its subsidiaries and authorized distributors provide product or system options for further investigation by users having technical expertise.
- The user, through its own analysis and testing, is solely responsible for making the final selection of the system and components and assuring that all performance, endurance, maintenance, safety and warning requirements of the application are met. The user must analyze all aspects of the application, follow applicable industry standards, and follow the information concerning the product in the current product catalog and in any other materials provided from Parker or its subsidiaries or authorized distributors.
- To the extent that Parker or its subsidiaries or authorized distributors provide component or system options based upon data or specifications provided by the user, the user is responsible for determining that such data and specifications are suitable and sufficient for all applications and reasonably foreseeable uses of the components or systems.

ATEX Gearboxes GXA Series



Overview 5

Technical Characteristics..... 6

Gearbox Inertia 7

Permitted radial and axial loads on output shaft of the gearbox..... 8

Dimensions 9

Gearbox Combinations 10

Order Code 12

Drawing 13

Series	<p style="text-align: center;">GXA</p> <div style="display: flex; justify-content: center; align-items: center;">   </div>
Description	Precision ATEX Planetary Gearboxes
Frame size [mm]	60, 90, 115, 142, 180, 220
Nominal Output Torque [Nm]	up to 1800
Radial Load [N]	up to 50 000
Minimum backlash [arcmin]	< 3
Maximum input speed [min ⁻¹]	up to 10 000
Ratio	3 to 100
Torsional rigidity [Nm/arcmin]	7 to 225

ATEX Gearboxes GXA Series

Overview

Description

GXA gearbox series has to be associated with the powerful Parker ATEX servomotors ranges for use in hazardous areas. The precision helical gearing design offers smooth and quiet operation for the most demanding high performance applications.

The solid uncaged needle roller bearings provides maximum contact points to increase stiffness and generates high output torque.

In addition the unique motor adapter and bushing module system design allows to obtain a compact structure and a quick and easy mounting of any ATEX certified Parker motor.

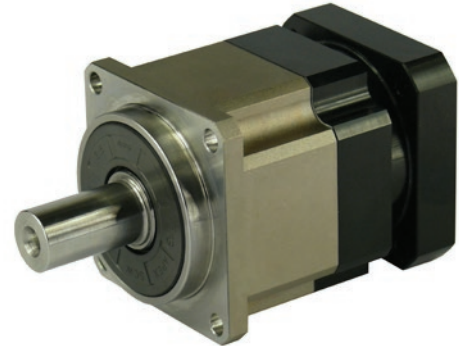

Features

- ATEX certify
- Low backlash
- High efficiency
- Easy mounting
- Low noise
- Compact structure
- Helical Gear Design



Technical Characteristics - Overview

Series	Unit	PS
Gear geometry		Helical Gearing
Type		In-Line
Frame sizes	[mm]	60, 90, 115, 142, 180, 220
Maximum input speed	[min ⁻¹]	up to 10 000
Nominal torque	[Nm]	40...1800
Radial force	[N]	up to 50 000
Life	[h]	up to 20 000
Backlash	[arcmin]	up to ≤ 3
Efficiency	[%]	up to ≥ 97 %
Category		Equipment Group II Category 2 in accordance with Directive 2014/34/EU
Harmonized standard		EN 1127-1:2012
Other technical standards & specifications applied		EN 13463-1:2009, EN 13463-5:2013, ISO281:2004, ISO286:2013, DIN3960

Technical Characteristics

Model No.		Stage	Ratio ¹	GX..R02..	GX..R04..	GX..R06..	GX..R07..	GX..R09..	GX..R10..
Nominal Output Torque T_{2N}	[Nm]	1	3	55	130	208	342	588	-
			4	50	140	290	542	1050	-
			5	60	160	330	650	1200	-
			6	55	150	310	600	1100	-
			7	50	140	300	550	1100	-
			8	45	120	260	500	1000	-
			9	40	100	230	450	900	-
			10	40	100	230	450	900	-
		2	15	-	130	208	342	588	-
			20	-	140	290	542	1050	-
			25	-	160	330	650	1200	-
			30	-	150	310	600	1100	-
			35	-	140	300	550	1100	-
			40	-	120	260	500	1000	-
			45	-	100	230	450	900	-
			50	-	160	330	650	1200	-
			60	-	150	310	600	1100	-
			70	-	140	300	550	1100	1800
			80	-	120	260	500	1000	1600
			90	-	100	230	450	900	1500
100	-	100	230	450	900	1500			
Emergency Stop Torque T_{2NOT}^3	[Nm]	1,2	3~100	3 times of Nominal Output Torque					
Nominal Input Speed n_{1N}	[min ⁻¹]	1,2	3~100	5000	4000	4000	3000	3000	2000
Max. Input Speed n_{1B}	[min ⁻¹]	1,2	3~100	10 000	8000	8000	6000	6000	4000
Standard Backlash	[arcmin]	1	3~10	≤ 5	≤ 5	≤ 5	≤ 5	≤ 5	≤ 5
		2	15~100	≤ 7	≤ 7	≤ 7	≤ 7	≤ 7	≤ 7
Reduced Backlash	[arcmin]	1	3~10	≤ 3	≤ 3	≤ 3	≤ 3	≤ 3	≤ 3
		2	15~100	≤ 5	≤ 5	≤ 5	≤ 5	≤ 5	≤ 5
Torsional Rigidity	[Nm / arcmin]	1,2	3~100	7	14	25	50	145	225
Max. Radial Load F_{2rB}^2	[N]	1,2	3~100	1530	3250	6700	9400	14500	50000
Max. Axial Load F_{2aB}^2	[N]	1,2	3~100	765	1625	3350	4700	7250	25000
Lifetime	[h]	1,2	3~100	20 000*					
Efficiency	[%]	1	3~10	≥ 97 %					
		2	15~100	≥ 94 %					
Weight	[kg]	1	3~10	1.3	3.7	7.8	14.5	29	48
		2	15~100	1.5	4.1	9	17.5	33	60
Operating Temp	[°C]	1,2	3~100	-10 to 40 °C					
Lubrication				Synthetic grease					
Degree of Gearbox Protection		1,2	3~100	IP65					
Mounting Position		1,2	3~100	All directions					
Noise Level ($n_1=3000 \text{ min}^{-1}$, No Load)	[dB(A)]	1,2	3~100	≤ 58	≤ 60	≤ 63	≤ 65	≤ 67	≤ 70

¹ Ratio (i=N in / N out)

² Applied to the output shaft center @ 100 min⁻¹

³ Max. acceleration torque $T_{2B} = 60\%$ of T_{2NOT}

*S1 service life 10,000 hrs.

Gearbox Inertia

Model No.	Unit	Stage	Ratio	GX..R02..	GX..R04..	GX..R06..	GX..R07..	GX..R09..	GX..R10..
Mass Moments of inertia J₁	[kgmm ²]	1	3	16	61	325	921	2898	-
			4	14	48	274	754	2367	-
			5	13	47	271	742	2329	-
			6	13	45	265	725	2275	-
			7	13	45	262	714	2248	-
			8	13	44	258	707	2259	-
			9	13	44	257	704	2253	-
			10	13	44	257	703	2251	-
		2	15	-	13	47	271	742	-
			20	-	13	47	271	742	-
			25	-	13	47	271	742	-
			30	-	13	47	271	742	-
			35	-	13	47	271	742	-
			40	-	13	47	271	742	-
			45	-	13	47	271	742	-
			50	-	13	44	257	703	-
			60	-	13	44	257	703	-
			70	-	13	44	257	703	2251
			80	-	13	44	257	703	2251
			90	-	13	44	257	703	2251
100	-	13	44	257	703	2251			

Permitted radial and axial loads on output shaft of the gearbox

The permitted radial and axial loads on output shaft of the gearbox depend on the design of the gearbox supporting bearings. GXA Series uses the extension straddle oversized ball bearing design. It can take heavy load from both axes.

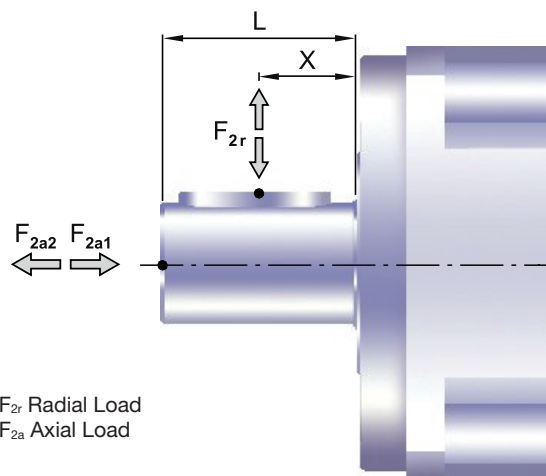

F_{2r} Radial Load
 F_{2a} Axial Load

If radial force F_{2r} exert on the center of the output shaft : $X=1/2 \times L$.

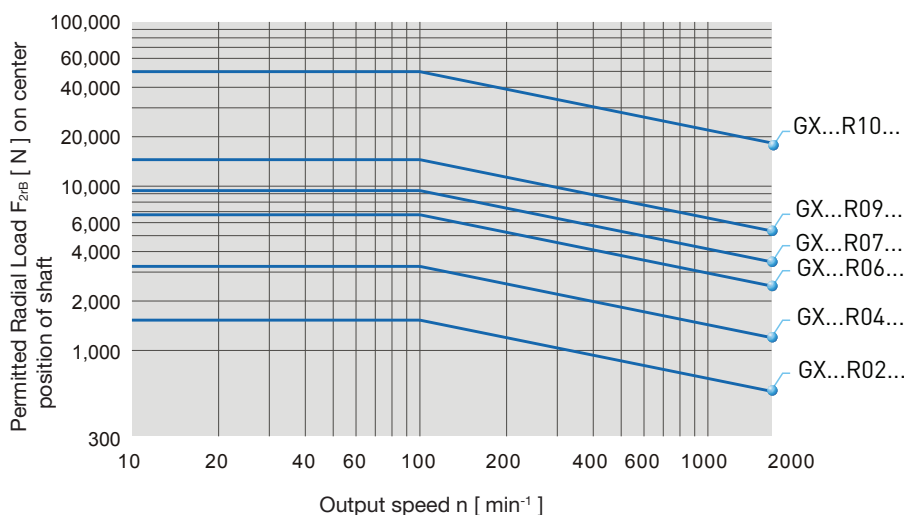

The permitted radial load is given on left diagram.

If radial force F_{2r} not exert on the center of the output shaft : $X < 1/2 \times L$ or $X > 1/2 \times L$

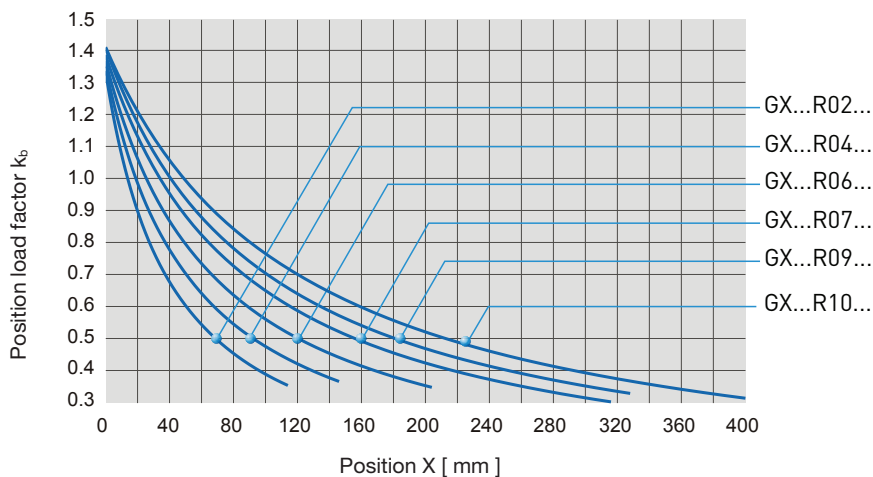

The permitted radial load can be calculated by multiplying the current by the position load factor k_b on the left diagram.

Dimensions

1 Stage - Ratio $i = 3 - 10$

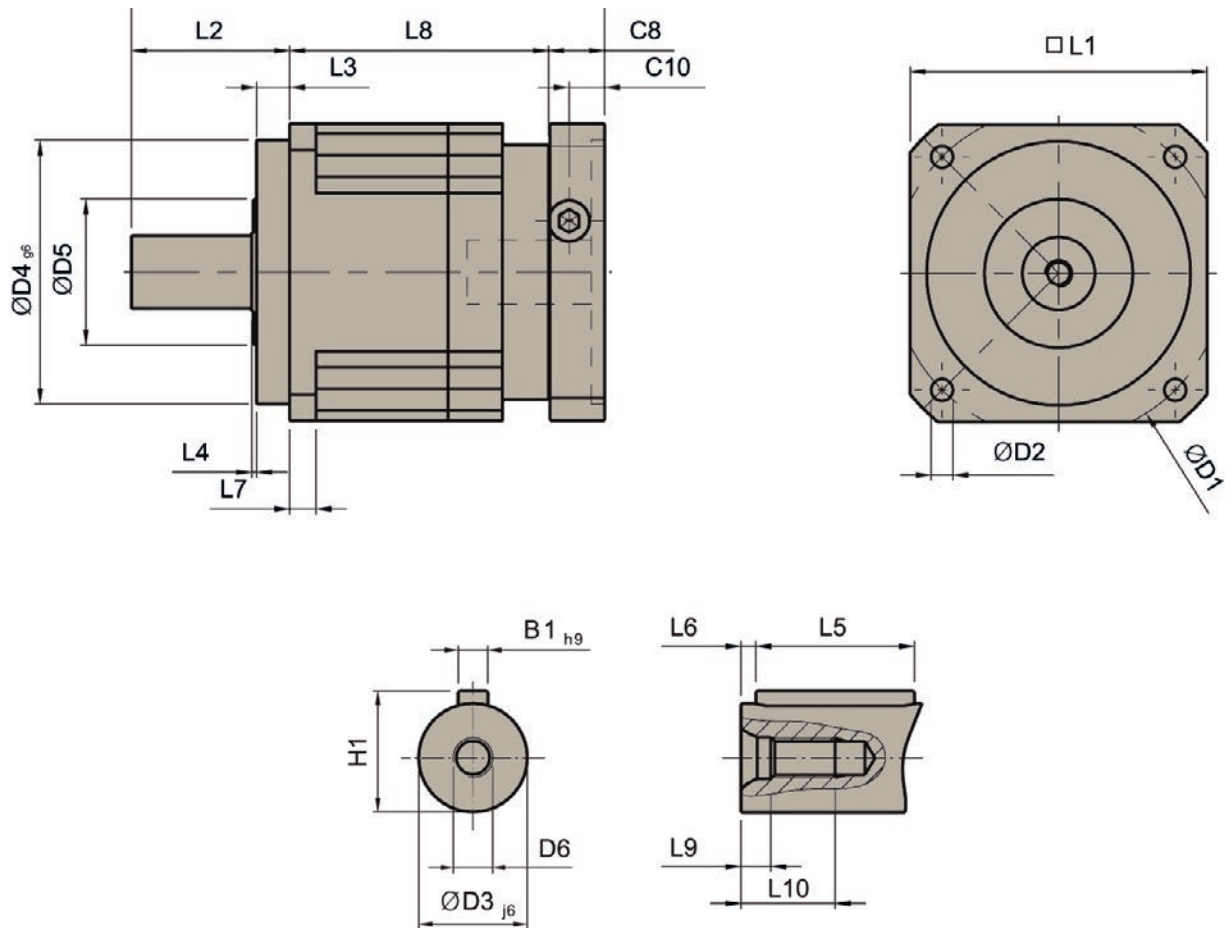

	GX..R02..	GX..R04..	GX..R06..	GX..R07..	GX..R09..
D1	70	100	130	165	215
D2	5.5	6.6	9	11	13
D3 j6	16	22	32	40	55
D4 g6	50	80	110	130	160
D5	45	65	95	75	95
D6	M5 x 0.8	M8 x 1.25	M12 x 1.75	M16 x 0.8	M20 x 2.5
L1	60	90	115	142	180
L2	37	48	65	97	105
L3	7	10	12	15	20
L4	1.5	1.5	2	3	3
L5	25	32	40	63	70
L6	2	3	5	5	6
L7	6	8	10	12	15
L8	61	78.5	102	119.5	154
L9	4.8	7.2	10	12	15
L10	12.5	19	28	36	42
C8 ³	19	17	19.5	22.5	29
C10 ³	13.5	10.75	13	15	20.75
B1 _{h9}	5	6	10	12	16
H1	18	24.5	35	43	59

³C8-C10 are motor specific dimensions.

2 Stages - Ratio $i = 15 - 100$

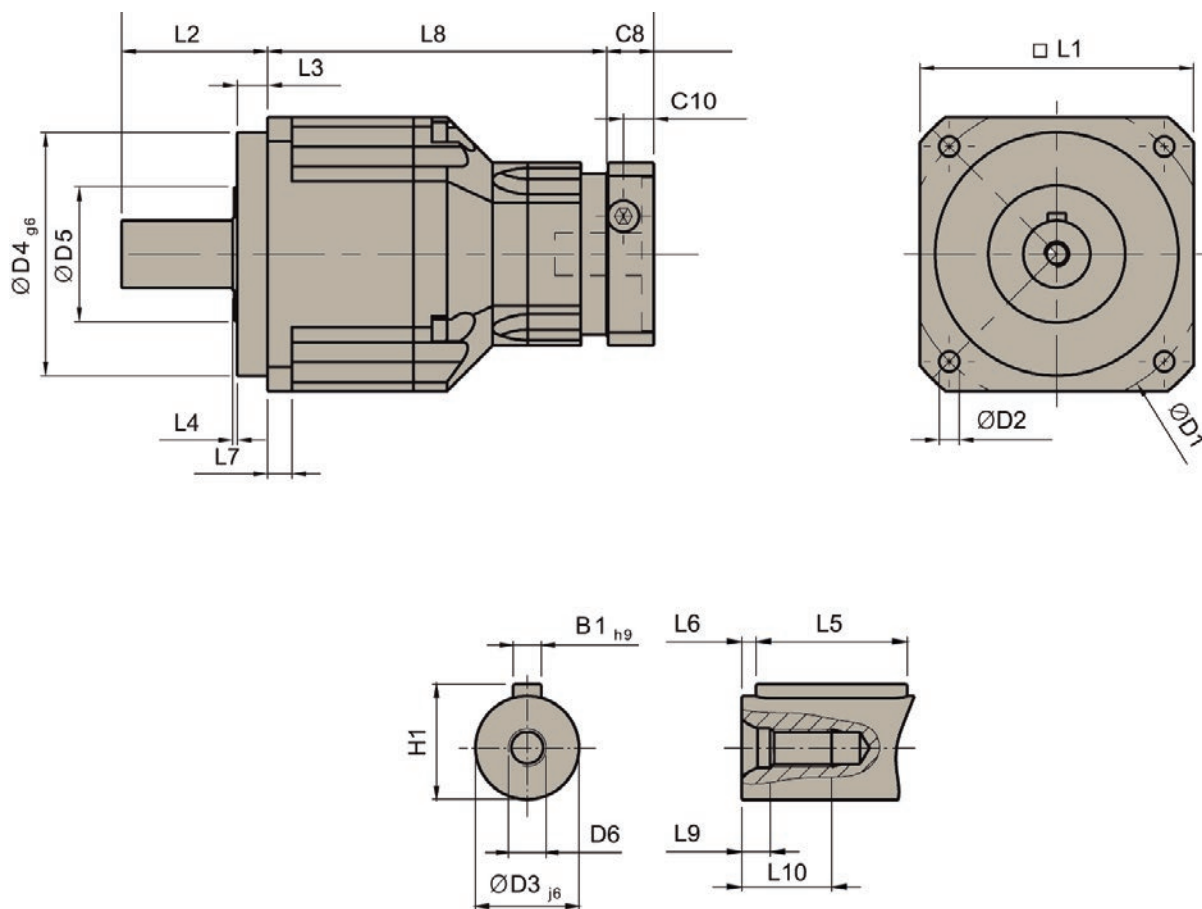

	GX..R04..	GX..R06..	GX..R07..	GX..R09..	GX..R10..
D1	100	130	165	215	250
D2	6.6	9	11	13	17
D3 j6	22	32	40	55	75
D4 g6	80	110	130	160	180
D5	65	95	75	95	115
D6	M8 x 1.25	M12 x 1.75	M16 x 2	M20 x 2.5	M20 x 2.5
L1	90	115	142	180	220
L2	48	65	97	105	138
L3	10	12	15	20	30
L4	1.5	2	3	3	3
L5	32	40	63	70	90
L6	3	5	5	6	7
L7	8	10	12	15	20
L8	111.5	143.5	176	209.5	248
L9	7.2	10	12	15	15
L10	19	28	36	42	42
C8 ⁴	19	17	19.5	22.5	29
C10 ⁴	13.5	10.75	13	15	20.75
B1 _{h9}	6	10	12	16	20
H1	24.5	35	43	59	79.5

4. C8-C10 are motor specific dimensions.

Gearbox Combinations

	Ratio	Motor Size				
		EX3 / EY3	EX4 / EY4	EX6 / EY6	EX8 / EY8	
1 stage	3	GXA3N003R0201	GXA4N003R0401	GXA6N003R0601	GXA8N003R0701	
	4	GXA3N004R0201	GXA4N004R0401	GXA6N004R0601	GXA8N004R0701	
	5	GXA3N005R0201	GXA4N005R0401	GXA6N005R0601	GXA8N005R0701	
	6	GXA3N006R0201	GXA4N006R0401	GXA6N006R0601	GXA8N006R0701	
	7	GXA3N007R0201	GXA4N007R0401	GXA6N007R0601	GXA8N007R0701	
	8	GXA3N008R0201	GXA4N008R0401	GXA6N008R0601	GXA8N008R0701	
	9	GXA3N009R0201	GXA4N009R0401	GXA6N009R0601	GXA8N009R0701	
	10	GXA3N010R0201	GXA4N010R0401	GXA6N010R0601	GXA8N010R0701	
2 stages	15	GXA3N015R0401	GXA4N015R0601	GXA6N015R0701	GXA8N015R0901	
	20	GXA3N020R0401	GXA4N020R0601	GXA6N020R0701	GXA8N020R0901	
	25	GXA3N025R0401	GXA4N025R0601	GXA6N025R0701	GXA8N025R0901	
	30	GXA3N030R0401	GXA4N030R0601	GXA6N030R0701	GXA8N030R0901	
	35	GXA3N035R0401	GXA4N035R0601	GXA6N035R0701	GXA8N035R0901	
	40	GXA3N040R0401	GXA4N040R0601	GXA6N040R0701	GXA8N040R0901	
	45	GXA3N045R0401	GXA4N045R0601	GXA6N045R0701	GXA8N045R0901	
	50	GXA3N050R0401	GXA4N050R0601	GXA6N050R0701	GXA8N050R0901	
	60	GXA3N060R0401	GXA4N060R0601	GXA6N060R0701	GXA8N060R0901	
	70			GXA4N070R0601		GXA8N070R0901
		GXA3N070R0401	GXA4N070R0701	GXA6N070R0701	GXA8N070R1001	
	80	GXA3N080R0401	GXA4N080R0601	GXA6N080R0701	GXA8N080R0901	
			GXA4N080R0701		GXA8N080R1001	
	90	GXA3N090R0401	GXA4N090R0601	GXA6N090R0701	GXA8N090R0901	
			GXA4N090R0701		GXA8N090R1001	
	100	GXA3N100R0401	GXA4N100R0601	GXA6N100R0701		
		GXA4N100R0701		GXA8N100R1001		

Motor gearhead possible combination with torque limitation, please consult us at EM-motion@parker.com

Order Code

GXA Gearboxes

	1	2	3	4	5	6	7
Order example	GX	A	3	N	005	R060	0

1 Gearbox Series	GX	Gearbox for in-line mounting
2 Gearbox Type	A	ATEX version
3 Motor size association *	3	EX3, EY3 (60/75/11/23)
	4	EX4, EY4 (80/100/19/40)
	6	EX6, EY6 (110/130/24/50)
	8	EX8, EY8 (130/165/32/58)
4 Backlash	N	Normal
	R	Reduced
5 Ratio	3 to 10	for GXA 1 stage
	15 to 100	for GXA 2 stages
6 Gearbox Size *	R020	Size 60
	R040	Size 90
	R060	Size 115
	R070	Size 142
	R090	Size 180
	R100	Size 220
7 Shaft	0	Smooth shaft
	1	Keyed shaft

* To find out about possible combinations please refer to the table on page 31.

Explosion proof servo motor

EX Series - Zone 1
www.parker.com/eme/ex



EY Series - Zone 2
www.parker.com/eme/ey

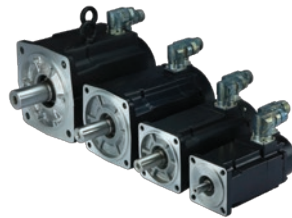

REDUCTEUR ATEX type GXA - ATEX GXA type GEARBOX

GXA3N010R0201 (montage avec moteur ATEX EX3 – Jeu Normal - Rapport 1/10 – Taille 60 – Arbre claveté)
 (to be fitted with EX3 ATEX motor – Normal backlash – Ratio 10:1 – Size 60 – Shaft with key)
ATEX - II2DGcT6

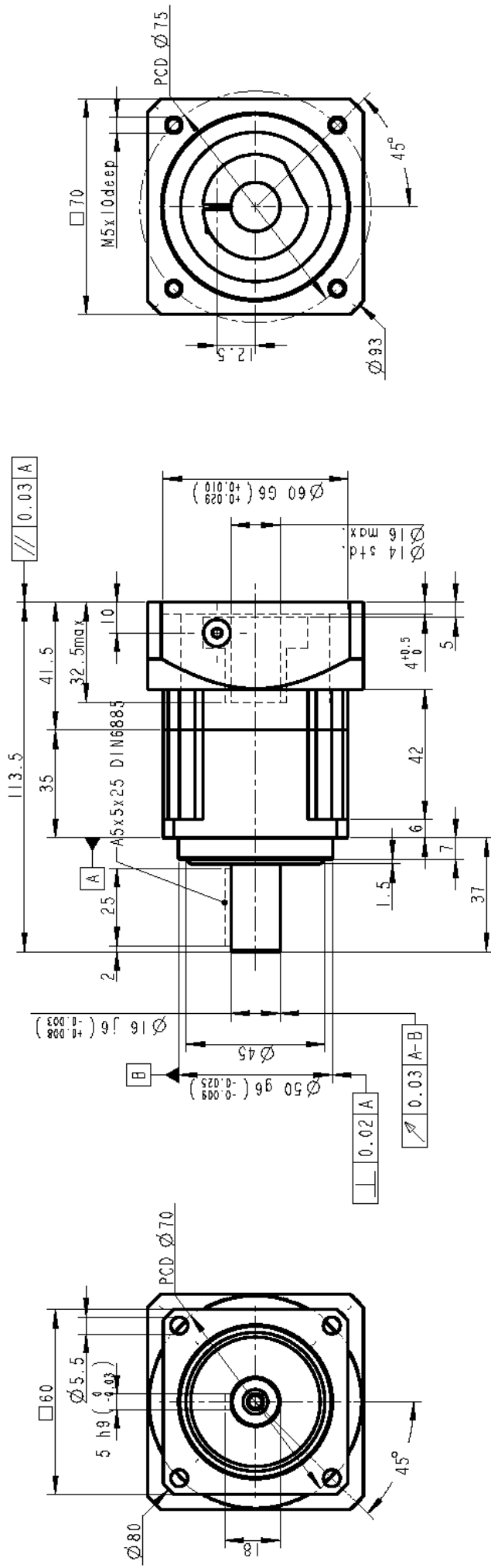

ATEX Gearboxes GXA Series
 Gearbox Drawing

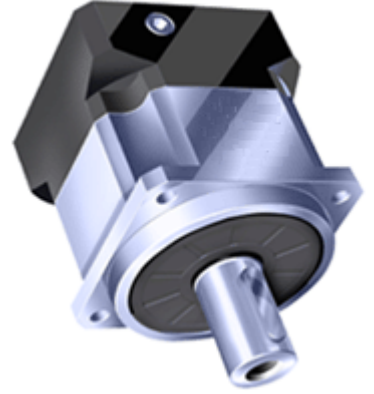

- | | |
|---|---------------------------------------|
| Rapport réduction : 10 | Masse : 1.3 kg |
| Couple sortie nominal : 40 Nm | Couple sortie maxi : 72 Nm |
| Vitesse entrée nominale : 5000 tr/mn | Vitesse entrée maximale : 10000 tr/mn |
| Jeu : 5 minutes | Rigidité : 7 Nm/min |
| Charge radiale (milieu arbre) : 1530 N | Charge axiale : 765 N |
| Rendement : 97% | Durée de vie : 20000 h |
| Inertie : 1.3 E-5 kgm ² | Température service : -10 à + 94°C |
| Lubrification : Graisse Synth.NYOGEL 792D | Protection : IP65 |
| Position montage : Toutes | Niveau sonore : < 58 dB (3000tr/mn) |

GXA3N100R0401 (montage avec moteur EX3 – Jeu Normal - Rapport 1/100 – Taille 90 – Arbre claveté)

(to be fitted with EX3 motor – Normal backlash – Ratio 100:1 – Size 90 – Shaft with key)

ATEX - II2DGcT6

ATTENTION : PREVOIR de LIMITER le COUPLE du MOTEUR – CAUTION : LIMIT the MOTOR TORQUE

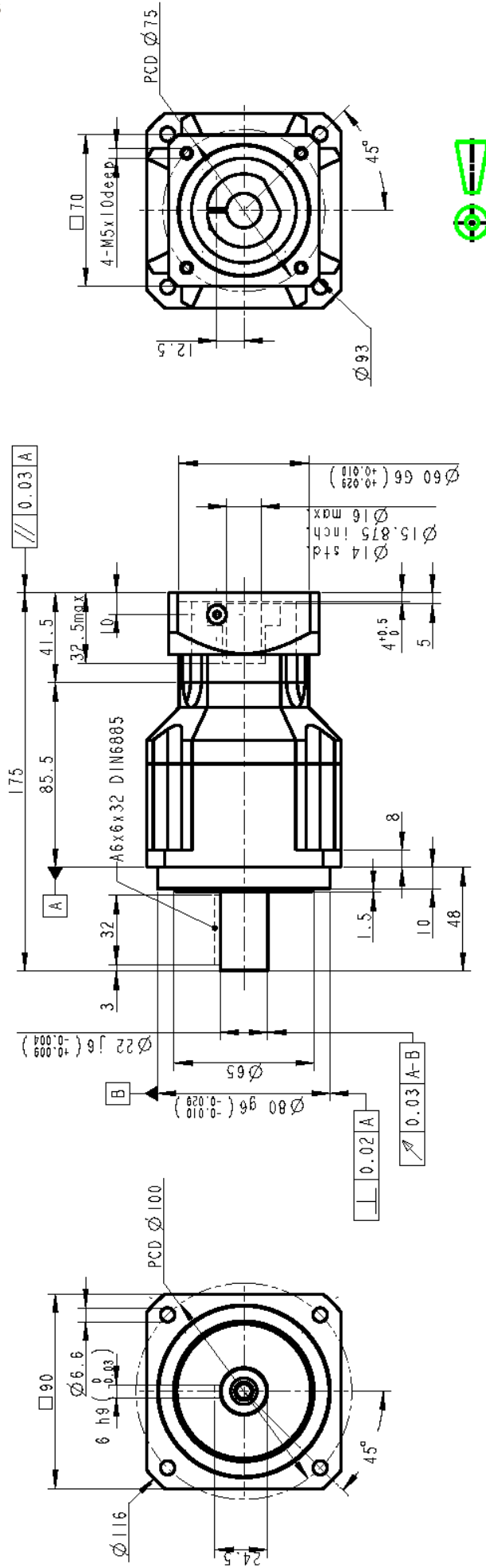

Rapport réduction : 100

Couple sortie nominal : 100 Nm
Vitesse entrée nominale : 4000 tr/mn
Jeu : 7 minutes
Charge radiale (milieu arbre) : 3250 N
Rendement : 94%
Inertie : 1.3 E-5 kgm²
Lubrification : Graisse Synth.NYOGEL 792D
Position montage : Toutes

Masse : 4.1 kg

Couple sortie maxi : 179 Nm
Vitesse entrée maximale : 8000 tr/mn
Rigidité : 14 Nm/min
Charge axiale : 1625 N
Durée de vie : 20000 h
Température service : -10 à +40°C
Protection : IP65
Niveau sonore : < 60 dB (3000tr/mn)

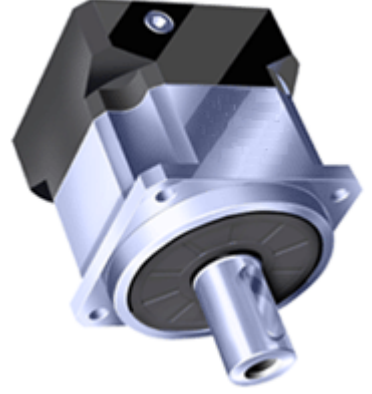

REDUCTEUR GX - GX GEARBOX

GXA4N010R0401 (montage avec moteur ATEX EX4 – Jeu Normal - Rapport 1/10 – Taille 90 – Arbre claveté)
 (to be fitted with EX4 ATEX motor – Normal backlash – Ratio 10:1 – Size 90 – Shaft with key)
ATEX - II2DGcT6

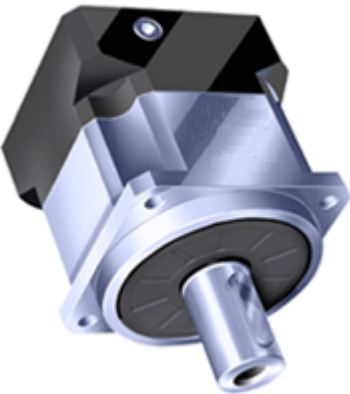
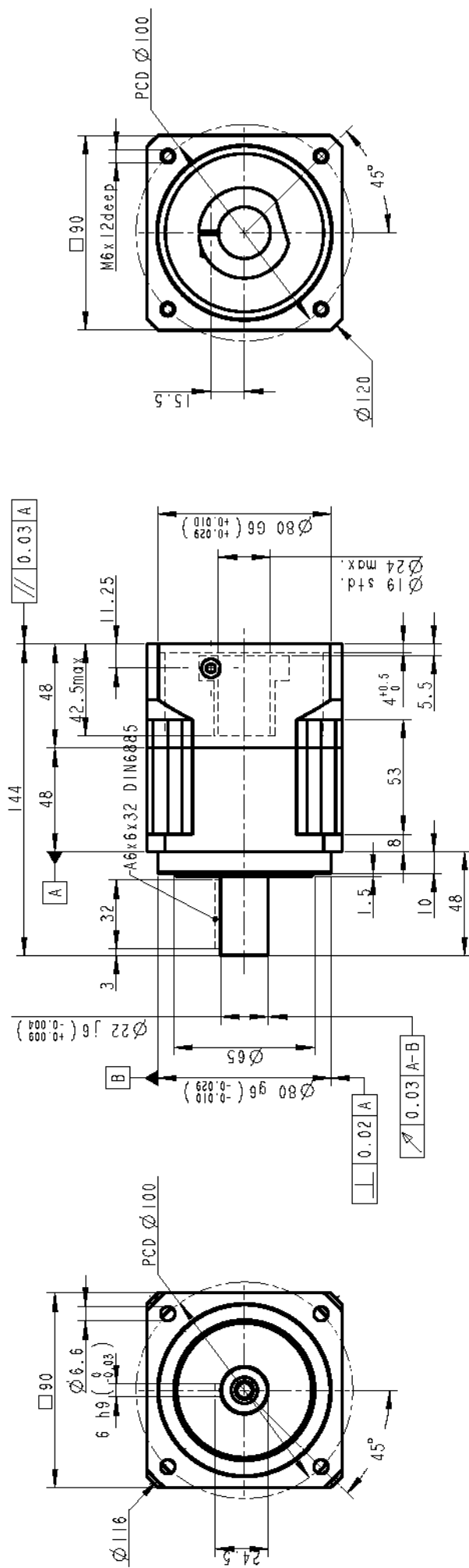

- | | |
|---|--------------------------------------|
| Rapport réduction : 10 | Masse : 3.7 kg |
| Couple sortie nominal : 100 Nm | Couple sortie maxi : 180 Nm |
| Vitesse entrée nominale : 4000 tr/mn | Vitesse entrée maximale : 8000 tr/mn |
| Jeu : 5 minutes | Rigidité : 14 Nm/min |
| Charge radiale (milieu arbre) : 3250 N | Charge axiale : 1625 N |
| Rendement : 97% | Durée de vie : 20000 h |
| Inertie : 4.4 E-5 kgm² | Température service : -10 à +40°C |
| Lubrification : Graisse Synth.NYOGEL 792D | Protection : IP65 |
| Position montage : Toutes | Niveau sonore : < 60 dB (3000tr/mn) |

GXA6N010R0601 (montage avec moteur EX6 110/130/24x50 – Jeu Normal - Rapport 1/10 – Taille 115 – Arbre claveté)
(to be fitted with EX6 motor 110/130/24x50 – Normal backlash – Ratio 10:1 – Size 115 – Shaft with key)

ATEX - II2DGcT6

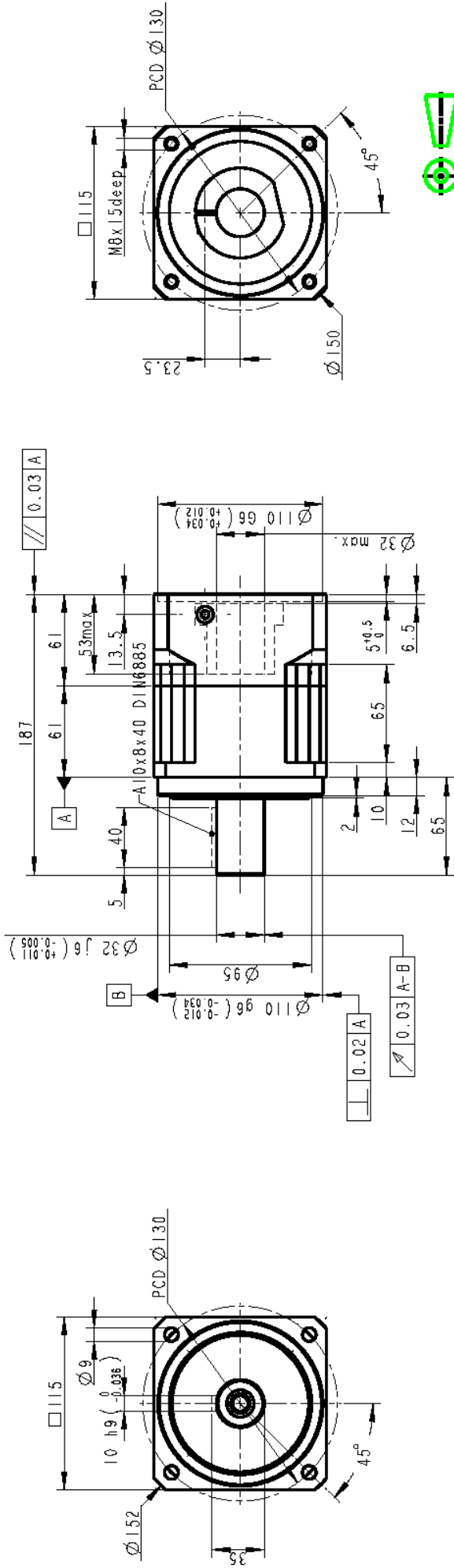

Rapport réduction : 10
 Couple sortie nominal : 230 Nm
 Vitesse entrée nominale : 4000 tr/mn
 Jeu : 5 minutes
 Charge radiale (milieu arbre) : 6700 N
 Rendement : 97%
 Inertie : 25.7 E-5 kgm²
 Lubrification : Graisse Synth.NYOGEL 792D
 Position montage : Toutes

Masse : 7.8 kg
 Couple sortie maxi : 414 Nm
 Vitesse entrée maximale : 8000 tr/mn
 Rigidité : 25 Nm/min
 Charge axiale : 3350 N
 Durée de vie : 20000 h
 Température service : -10 à +40°C
 Protection : IP65
 Niveau sonore : < 63dB (3000tr/mn)

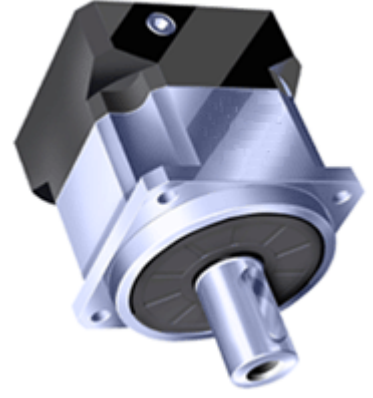

GXA8N090R1001 (montage avec moteur NX8 130/165/32x58 – Jeu Normal - Rapport 1/90 – Taille 220 – Arbre claveté)
 (to be fitted with NX8 motor 130/160/32x58 – Normal backlash – Ratio 90:1 – Size 220 – Shaft with key)
ATEX - II2DGcT6

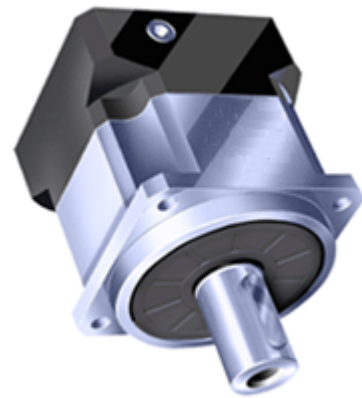
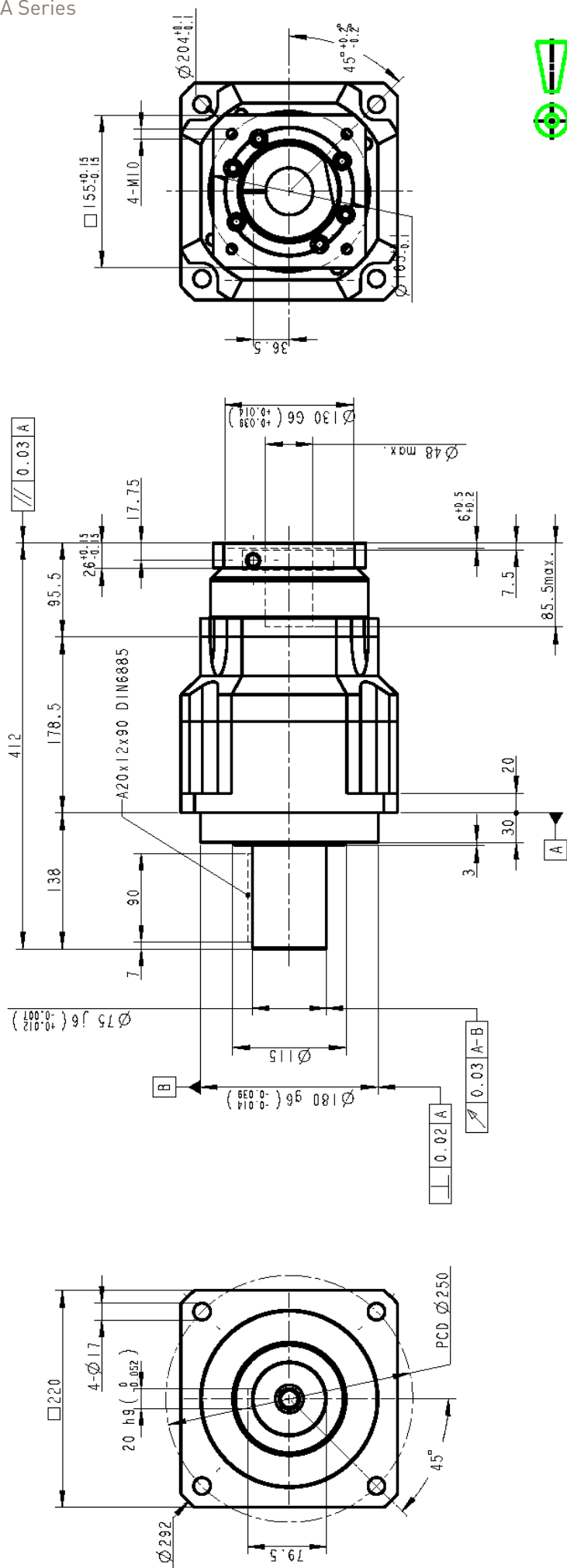

Rapport réduction : 90

- Couple sortie nominal : 1500 Nm
- Vitesse entrée nominale : 2000 tr/mn
- Jeu : 7 minutes
- Charge radiale (milieu arbre) : 50000 N
- Rendement : 94%
- Inertie : 225.1 E-5 kgm²
- Lubrification : Graisse Synth.NYOGEL 792D
- Position montage : Toutes

Masse : 60 kg

- Couple sortie maxi : 2700 Nm
- Vitesse entrée maximale : 4000 tr/mn
- Rigidité : 225 Nm/min
- Charge axiale : 25000 N
- Durée de vie : 20000 h
- Température service : -10 à +40°C
- Protection : IP65
- Niveau sonore : < 70 dB (3000tr/mn)



北京润诚时代科技有限公司

地址：北京市朝阳区汤立路218号A座 301 室

电话：010-84450370

网址：www.runcheng.net

邮箱：runcheng_emd@sina.com