

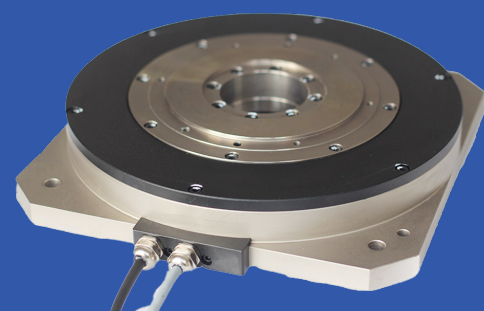

直驱力矩电机

DD 系列

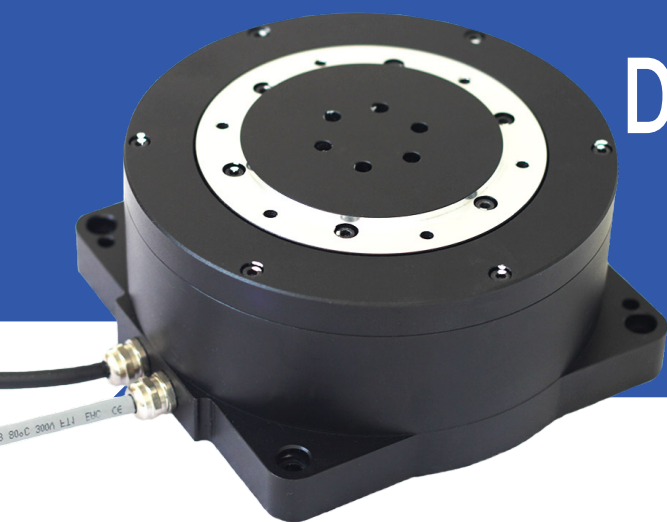

北京润诚时代科技有限公司

www.runcheng.net

产品目录

DD系列直驱力矩电机

概述	01
命名规则	01

DDW系列外转子直驱力矩电机

技术指标	02
机械尺寸	03

DDN系列内转子直驱力矩电机

技术指标	24
机械尺寸	25

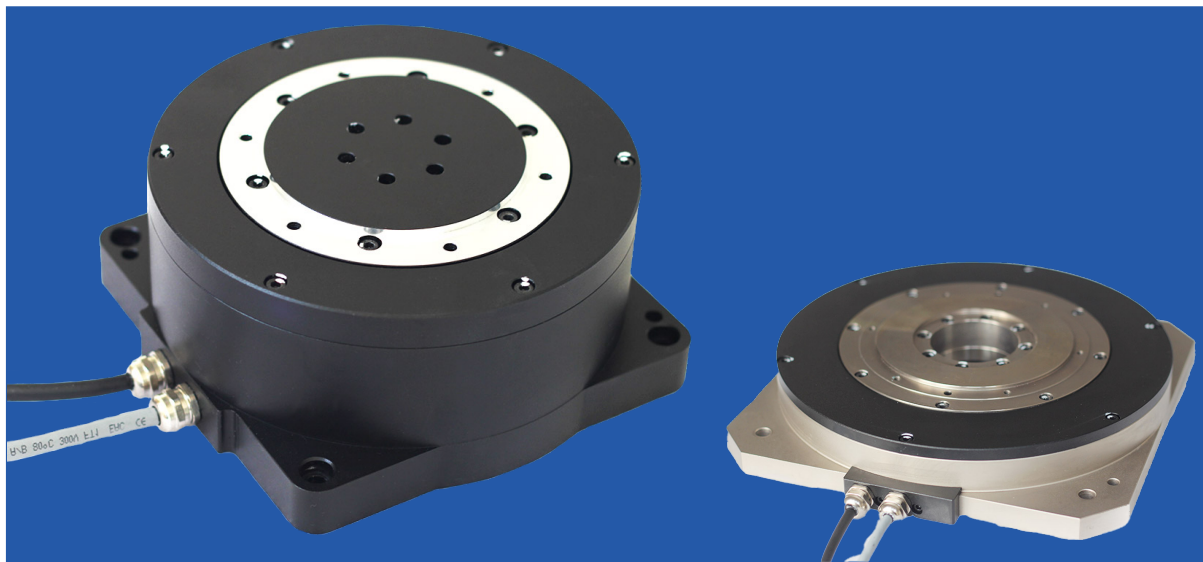

DD 系列直驱力矩电机

概述

DD 系列直驱力矩电机的一体化结构，使负载可以直接安装在直驱力矩电机的安装面上，所以由电机到工位盘之间没有精度损失。这样就增加了设备的精度。因为没有减速机等机械结构，所以没有像传统交流伺服那样的能量损失。用直接驱动方式使得通过程序改变工位变得很容易。

命名规则

DD 系列直驱力矩电机的命名方法。

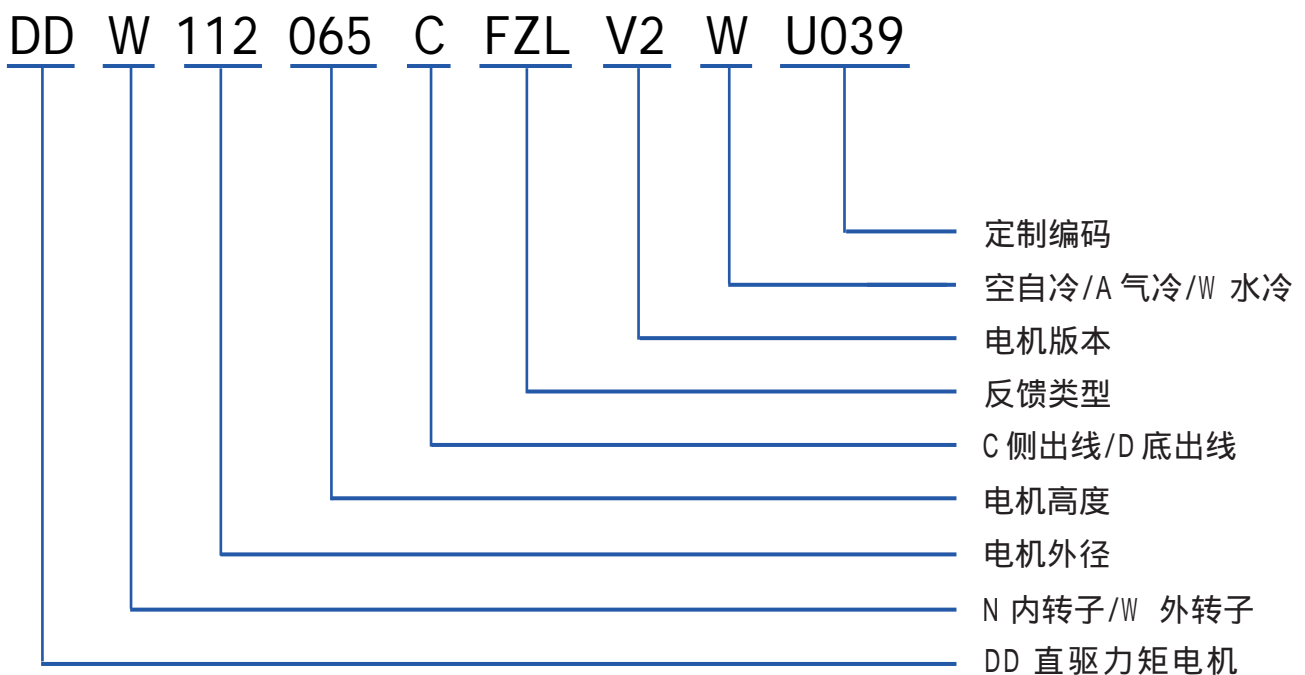

DDW 外转子直驱力矩电机

技术指标

电机型号	通孔直径 mm	连续 转矩 Nm	连续 电流 Arms	最大 转矩 Nm	最大 电流 Arms	最高 转速 rpm	定位 精度 arc sec	重复 精度 arc sec	电机 重量 kg
DDW-112065-C-FA	24	3	2.5	9	7.5	350	±20	±1.5	3.2
DDW-120025-C-FQL	15	1	0.65	3	2.0	500	±30	±2.5	1.3
DDW-140050-C-FA	30	6	2.5	16	7.0	600	±20	±1.5	3.4
DDW-140077-C-FA-V2	24	3	2.5	9	7.5	350	±20	±1.5	3.4
DDW-140077-C-FA	24	3	2.5	9	7.5	350	±20	±1.5	3.4
DDW-140080-C-FA	20	10	2.5	28	7.0	350	±20	±1.5	5.6
DDW-140085-D-FA	20	10	2.5	28	7.0	350	±20	±1.5	5.6
DDW-140095-C-FA	20	10	2.5	28	7.0	350	±20	±1.5	6.8
DDW-140092-C-FA	20	3	2.5	9	7.5	350	±20	±1.5	4.1
DDW-163092-C-FA	42	11.7	3.0	35	9.0	200	±20	±1.5	7.1
DDW-170050-C-FA	42	4.5	1.4	14	4.2	450	±20	±1.5	3.9
DDW-170055-C-FA	50	4.5	1.4	14	4.2	450	±20	±1.5	4.2
DDW-170056-C-FA	42	4.5	1.4	14	4.2	450	±20	±1.5	4.2
DDW-170095-C-FA	42	23.8	2.5	71	7.5	190	±20	±1.5	10.1
DDW-170110-C-FA	45	23.8	2.5	74	7.5	190	±20	±1.5	10.5
DDW-170118-D-FA	30	23.8	2.5	74	7.5	190	±20	±1.5	12
DDW-170125-C-FA	42	41.8	2.5	125	7.5	150	±20	±1.5	13.9
DDW-170130-C-FA	42	41.8	2.5	125	7.5	150	±20	±1.5	14.2
DDW-170155-C-FA	42	50.5	2.5	179	7.5	120	±20	±1.5	18.1
DDW-190100-C-FA	50	20	3.0	60	9.0	200	±20	±1.5	8.7
DDW-220062-C-FA	81	10	3.0	30	9.0	320	±20	±1.5	8.9
DDW-224042-C-FA	50.5	14	2.2	42	6.6	380	±20	±1.5	5.5
DDW-224062-C-FA	50.5	35	2.2	105	6.6	200	±20	±1.5	9.2
DDW-260035-C-FQL	160	45	7.1	135	21.3	200	±30	±5.0	12.8
DDW-263065-C-FA	70	45	7.1	135	21.3	200	±20	±1.5	13.1
DDW-263095-C-FA	80	45	7.1	135	21.3	200	±20	±1.5	19.3
DDW-263095-D-FA	80	45	7.1	135	21.3	200	±20	±1.5	18.5
DDW-263112-D-FA	80	95	7.1	190	14.2	150	±20	±1.5	25
DDW-263113-D-FA	80	95	7.1	190	14.2	150	±20	±1.5	24.4
DDW-263134-D-FA2	80	150	7.1	300	14.2	120	±20	±1.5	32
DDW-263138-C-FA	80	150	7.1	300	14.2	120	±20	±1.5	32.5
DDW-263138-D-FA	80	150	7.1	300	14.2	120	±20	±1.5	35
DDW-263188-C-FA	80	250	7.1	500	14.2	100	±20	±1.5	49
DDW-263188-D-FA	80	250	7.1	500	14.2	100	±20	±1.5	48
DDW-163215-D-FA	80	250	7.1	500	14.2	100	±20	±1.5	66.5
DDW-280145-C-FA	80	95	7.1	190	14.2	150	±20	±1.5	28.5
DDW-280170-C-FA	80	95	7.1	190	14.2	150	±20	±1.5	32
DDW-280231-C-FA	80	250	7.1	500	14.2	100	±20	±1.5	57
DDW-325065-C-FA	80	30	1.1	90	3.4	120	±20	±1.5	15.5
DDW-400052-C-FQL	235	32	1.2	80	3.0	120°	±20	±1.5	16.9
DDW-500065-C-FQL	310	43	2.0	86	4.0	175°	±30	±2.5	29.5
DDW-560067-C-FQL	360	50	1.0	125	2.5	180°	±30	±2.5	38.5

DDW 外转子直驱力矩电机

机械尺寸

DDW-112065-C-FA

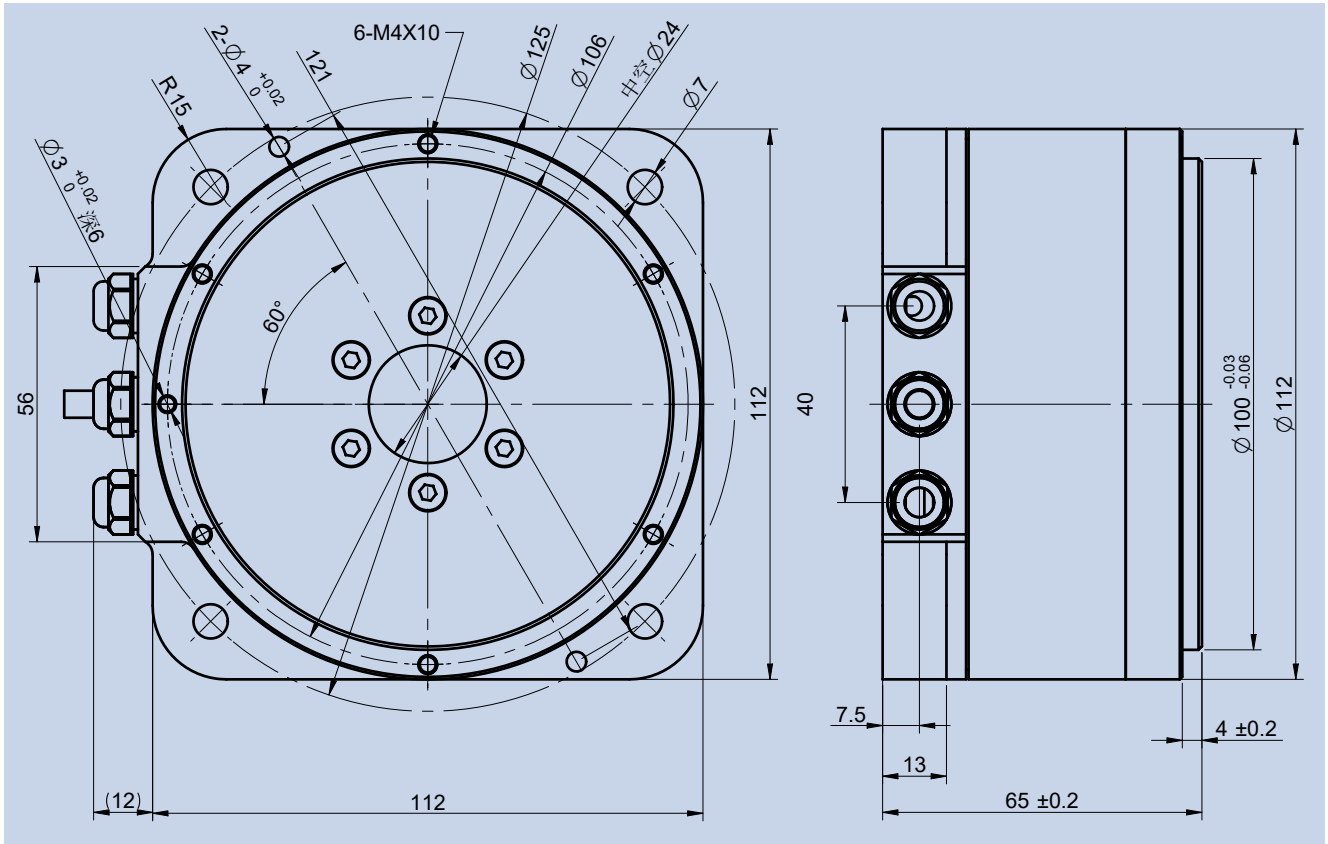

DDW-120025-C-FQL

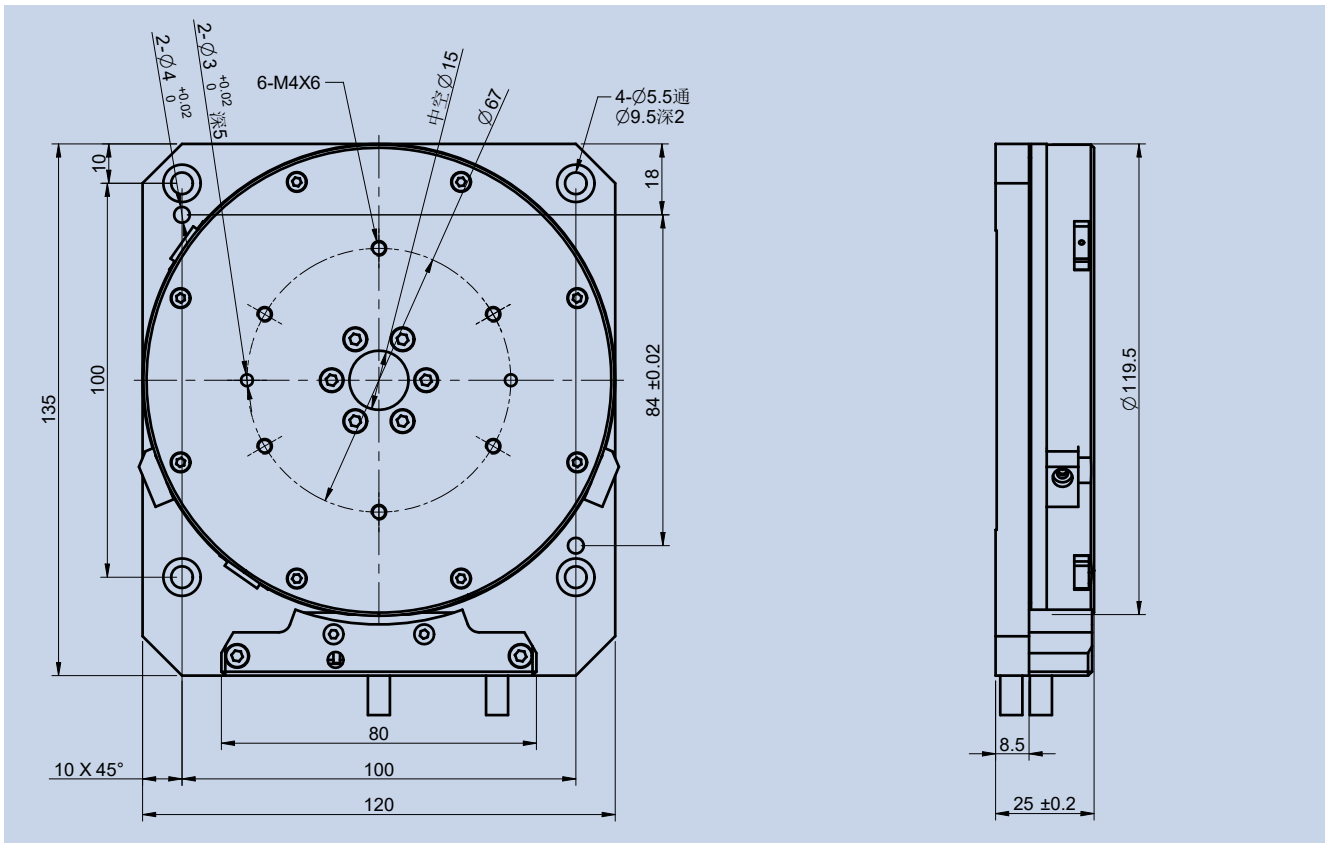

DDW 外转子直驱力矩电机

机械尺寸

DDW-140050-C-FA

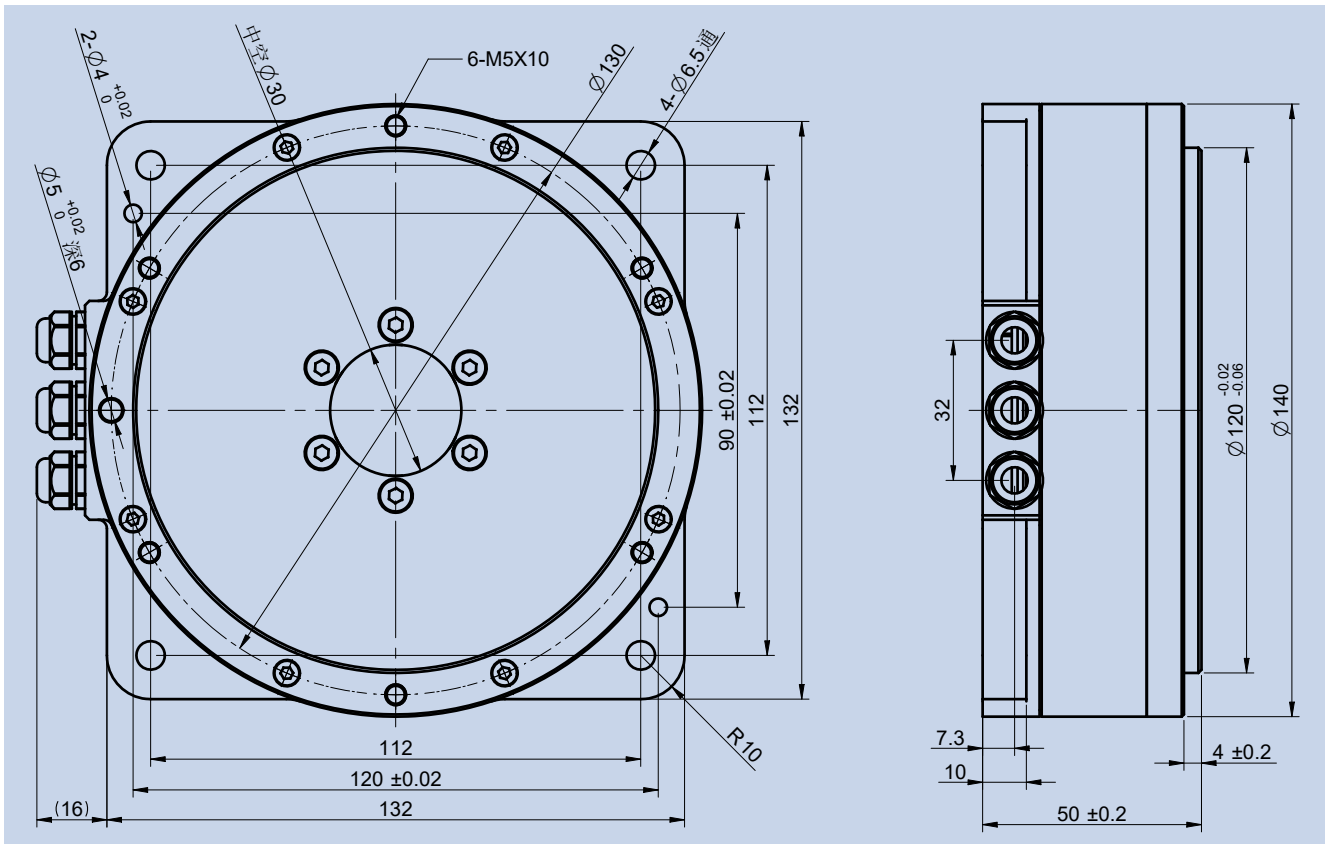

DDW-140077-C-FA

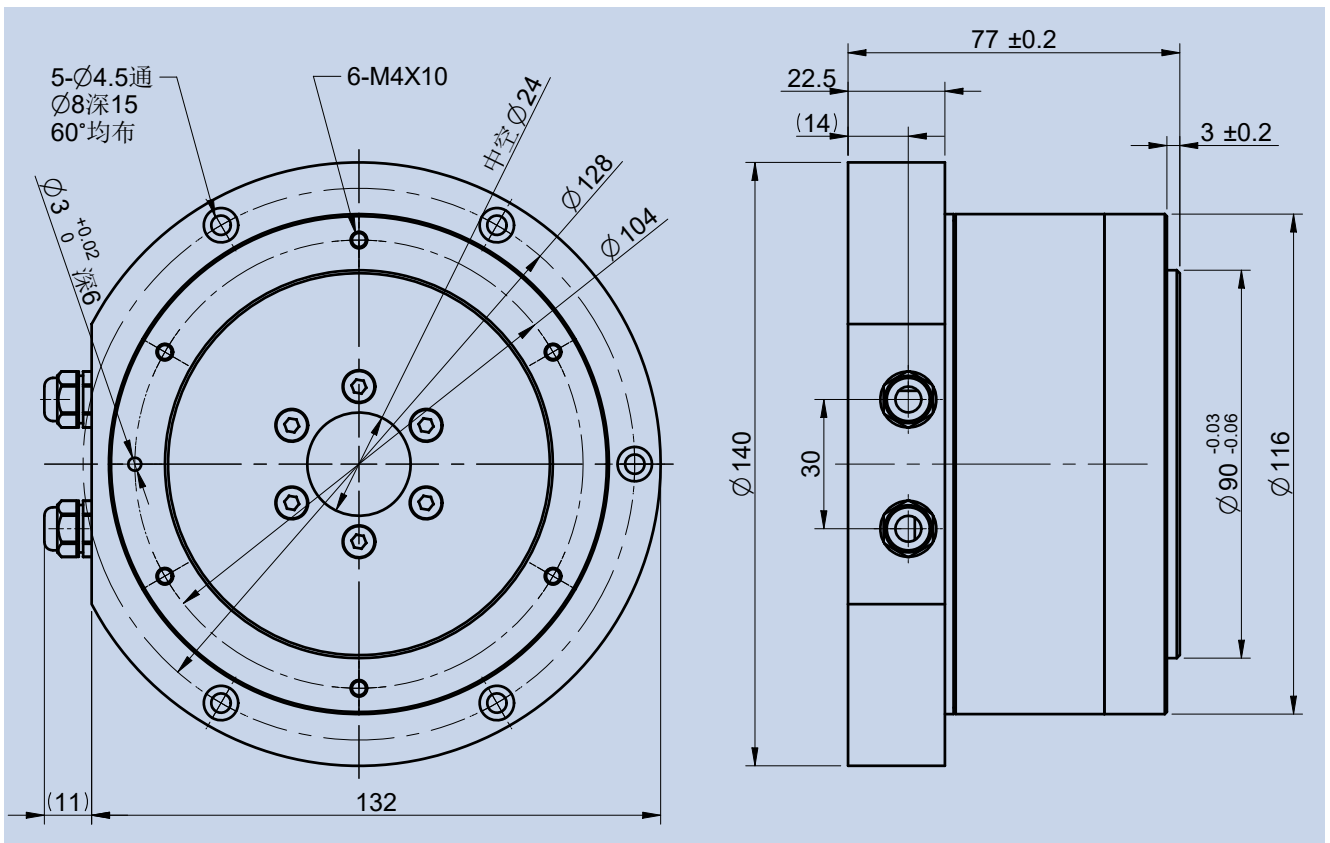

DDW 外转子直驱力矩电机

机械尺寸

DDW-140077-C-FA-V2

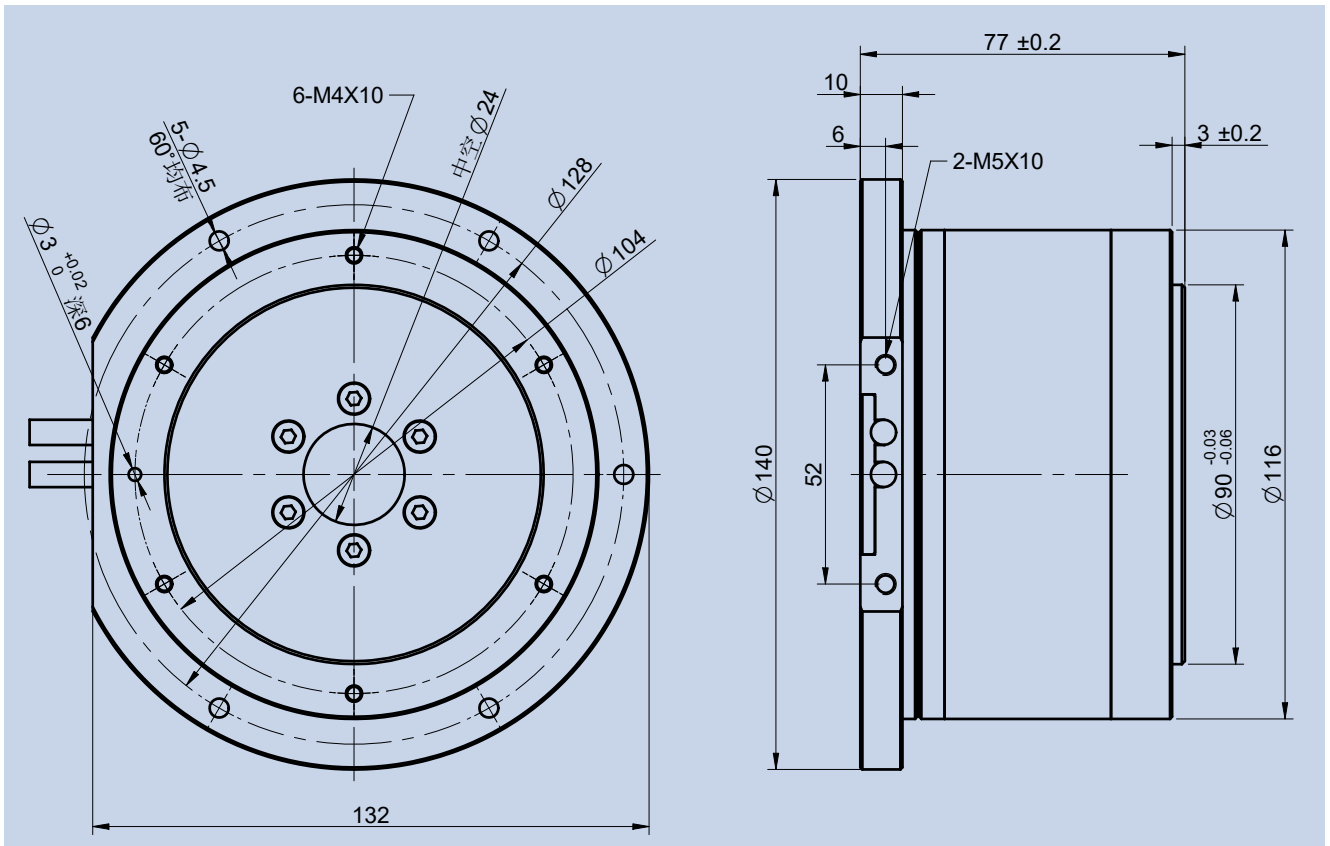

DDW-140080-C-FA

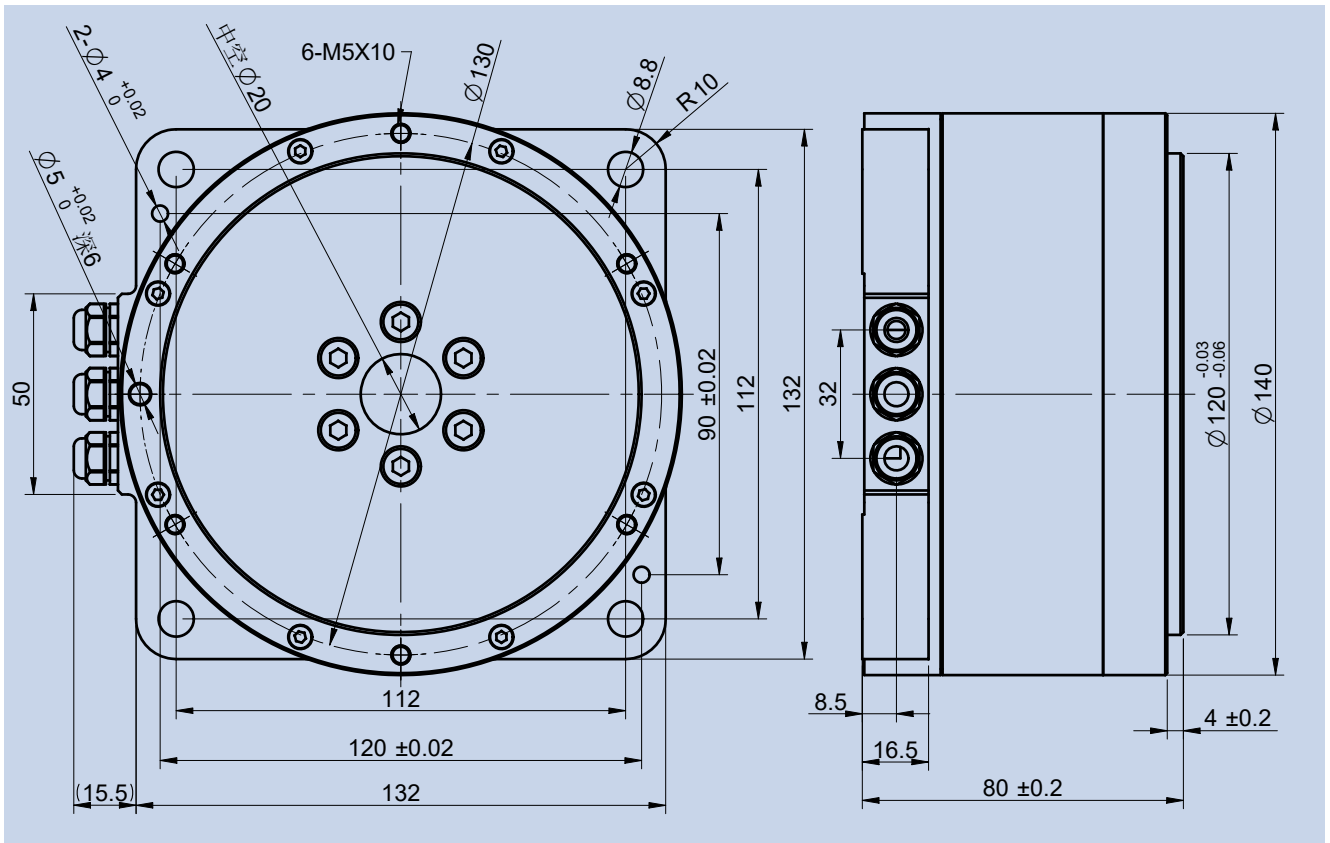

DDW 外转子直驱力矩电机

机械尺寸

DDW-140085-D-FA

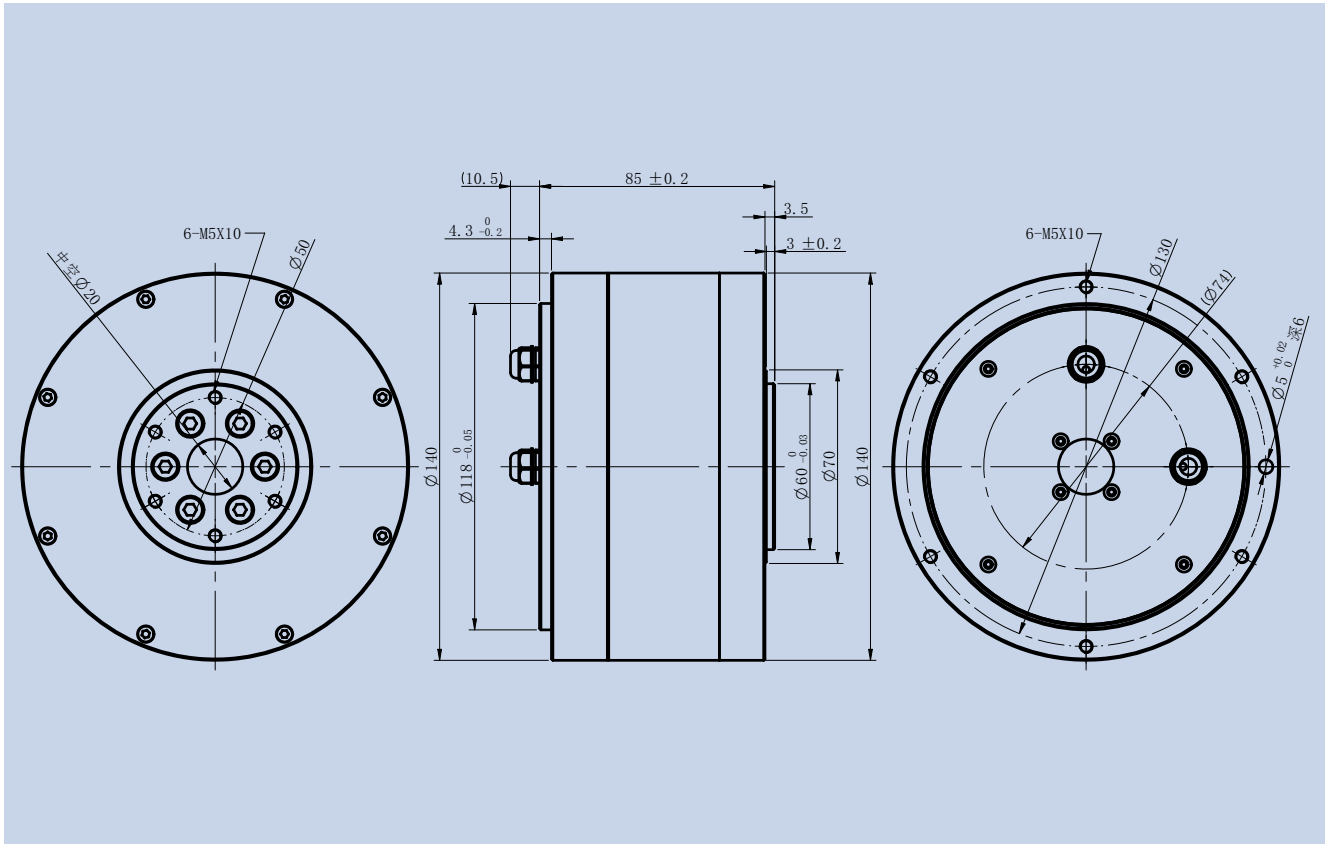

DDW-140095-C-FA

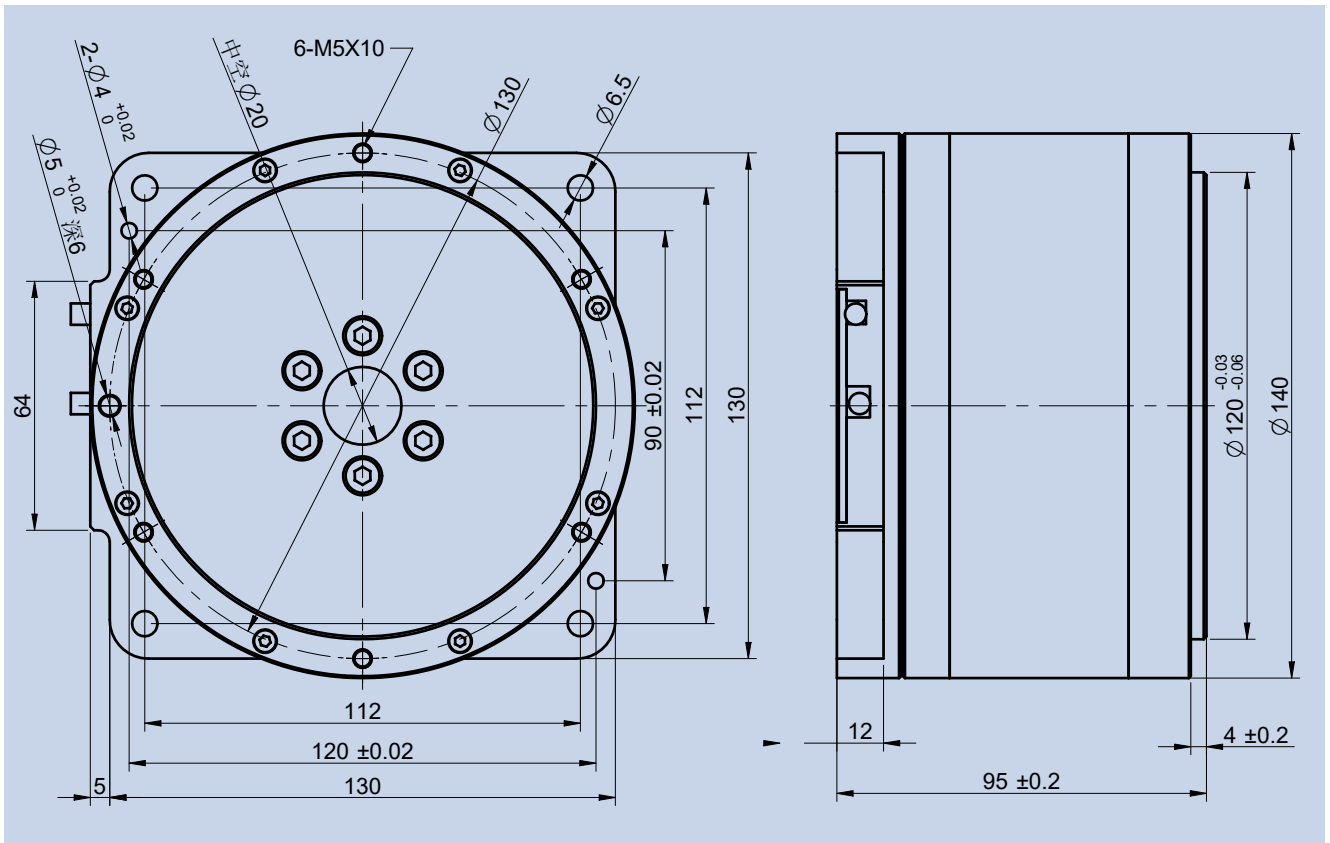

DDW 外转子直驱力矩电机

机械尺寸

DDW-144092-C-FA

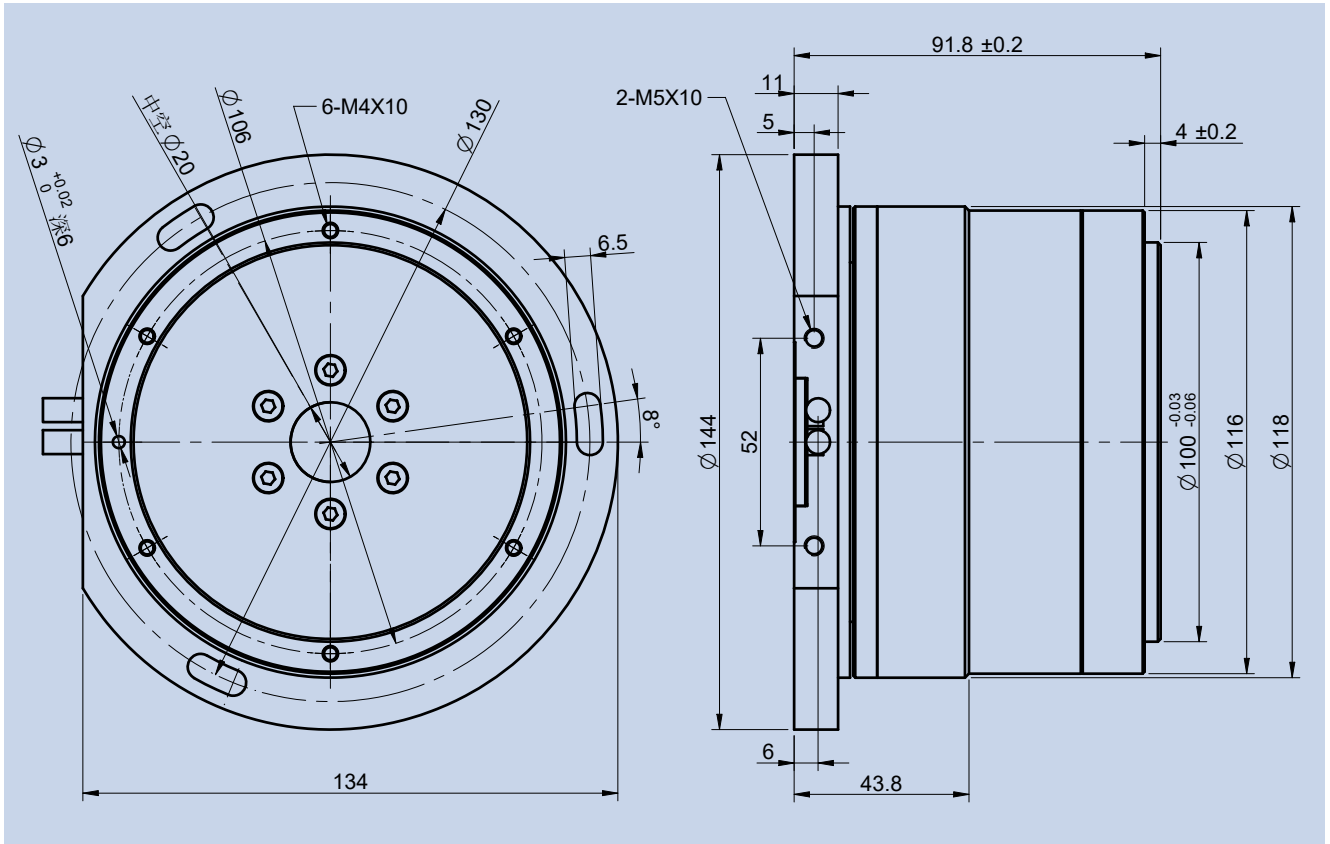

DDW-163092-C-FA

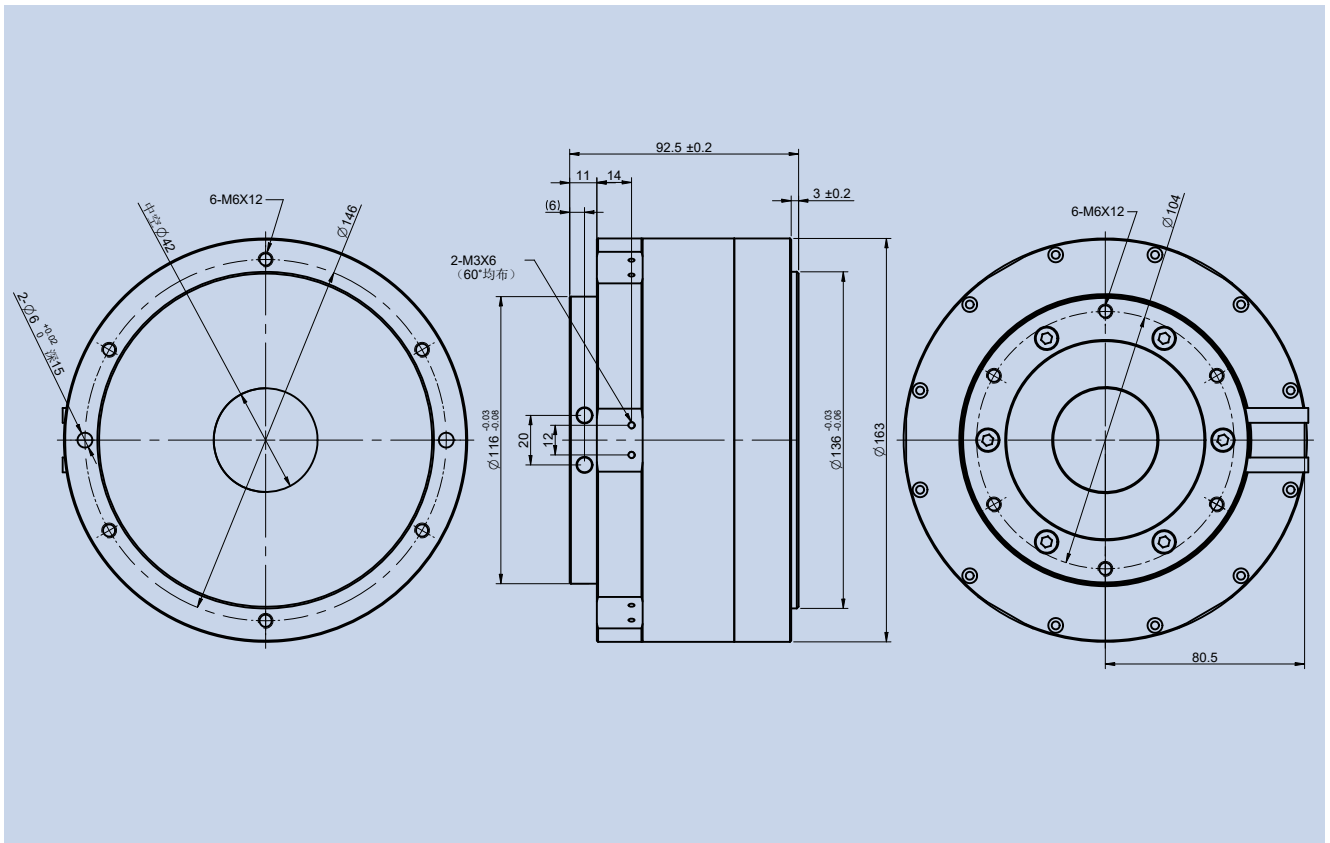

DDW 外转子直驱力矩电机

机械尺寸

DDW-170050-C-FA

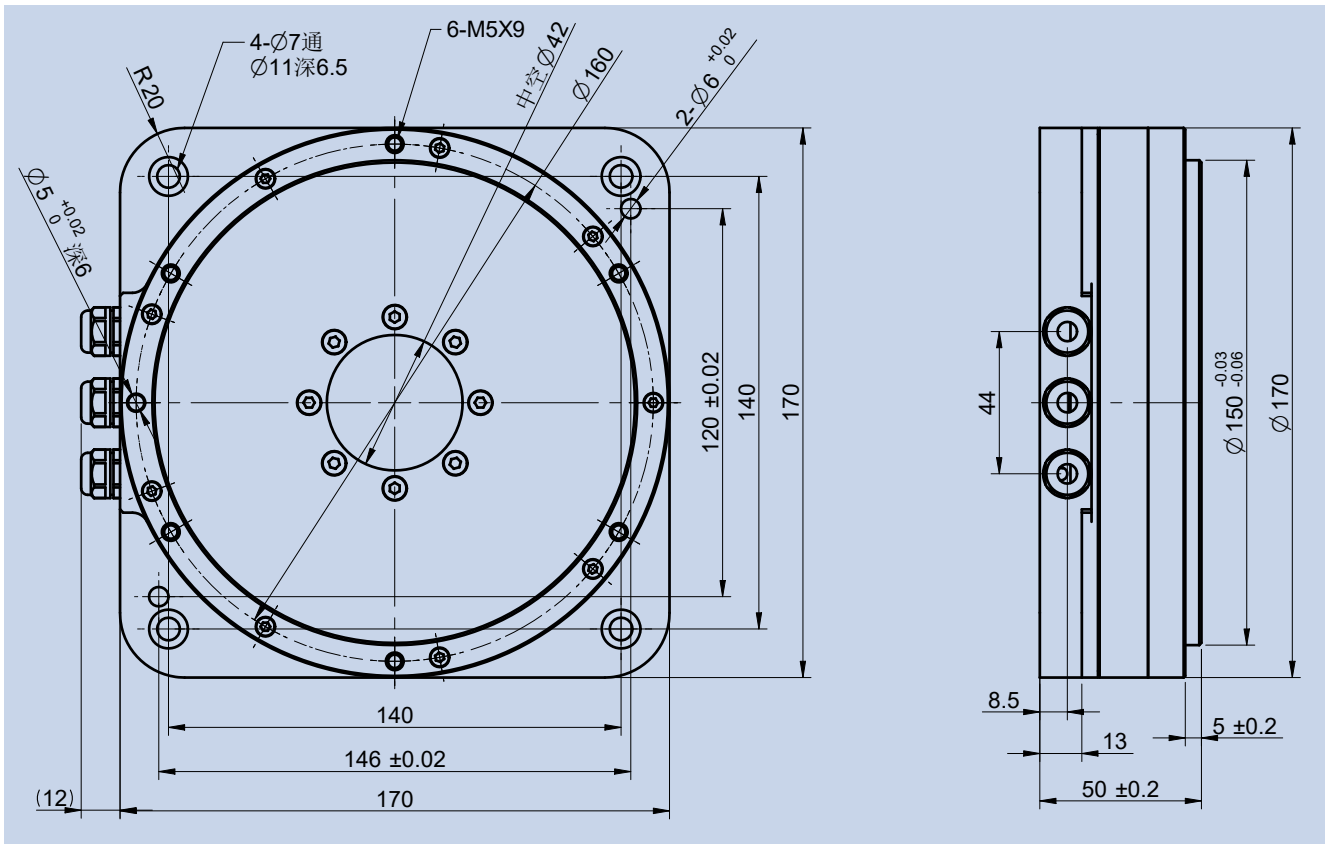

DDW-170055-C-FA

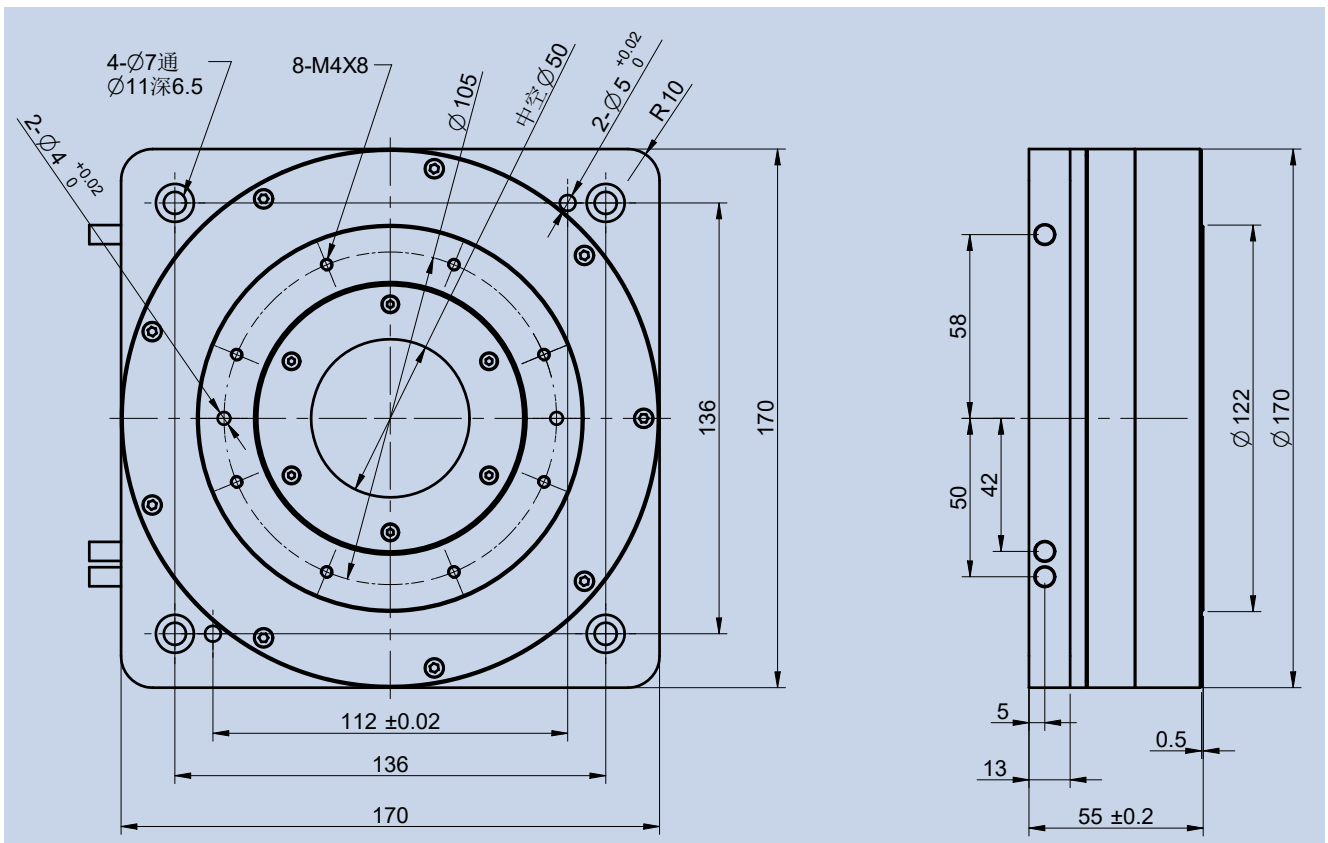

DDW 外转子直驱力矩电机

机械尺寸

DDW-170056-C-FA

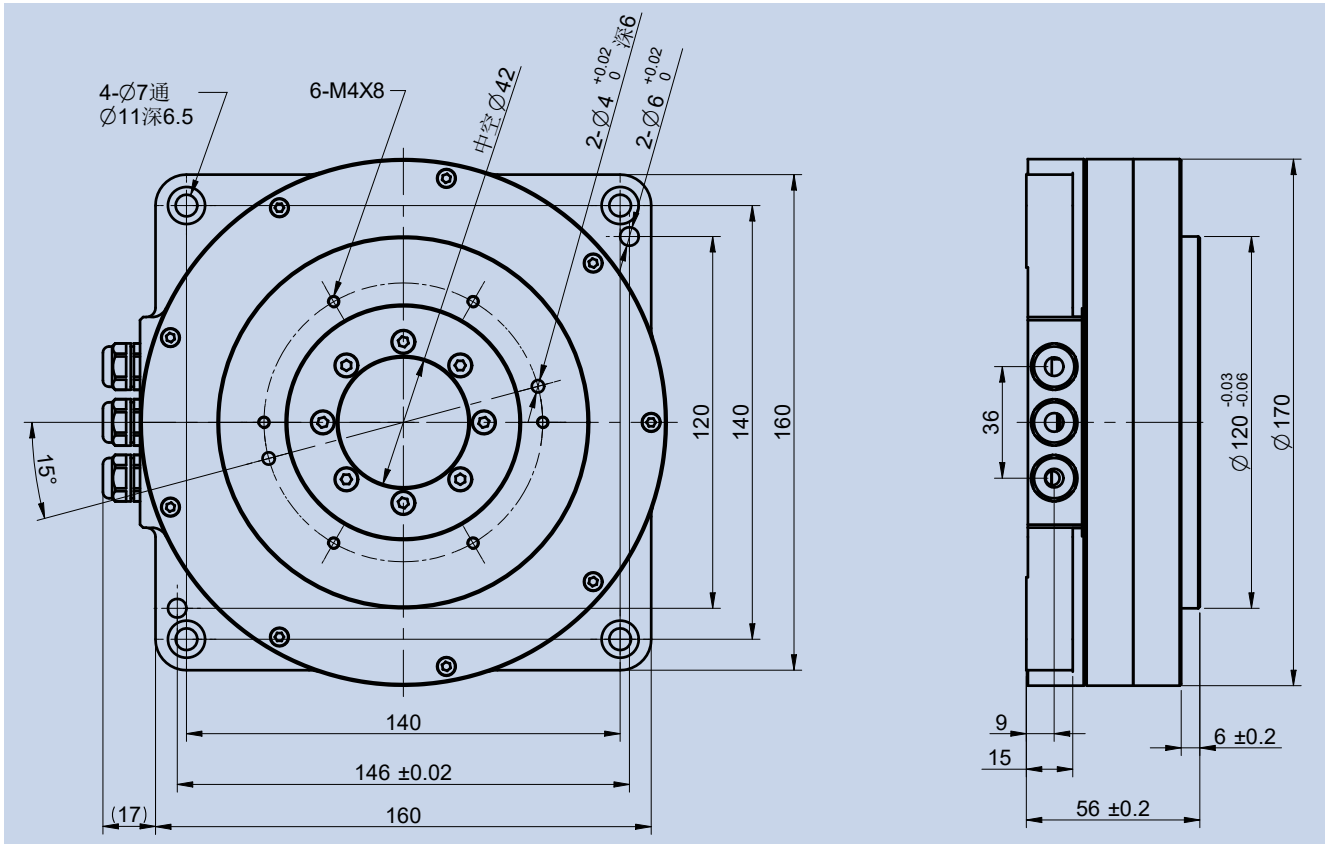

DDW-170095-C-FA

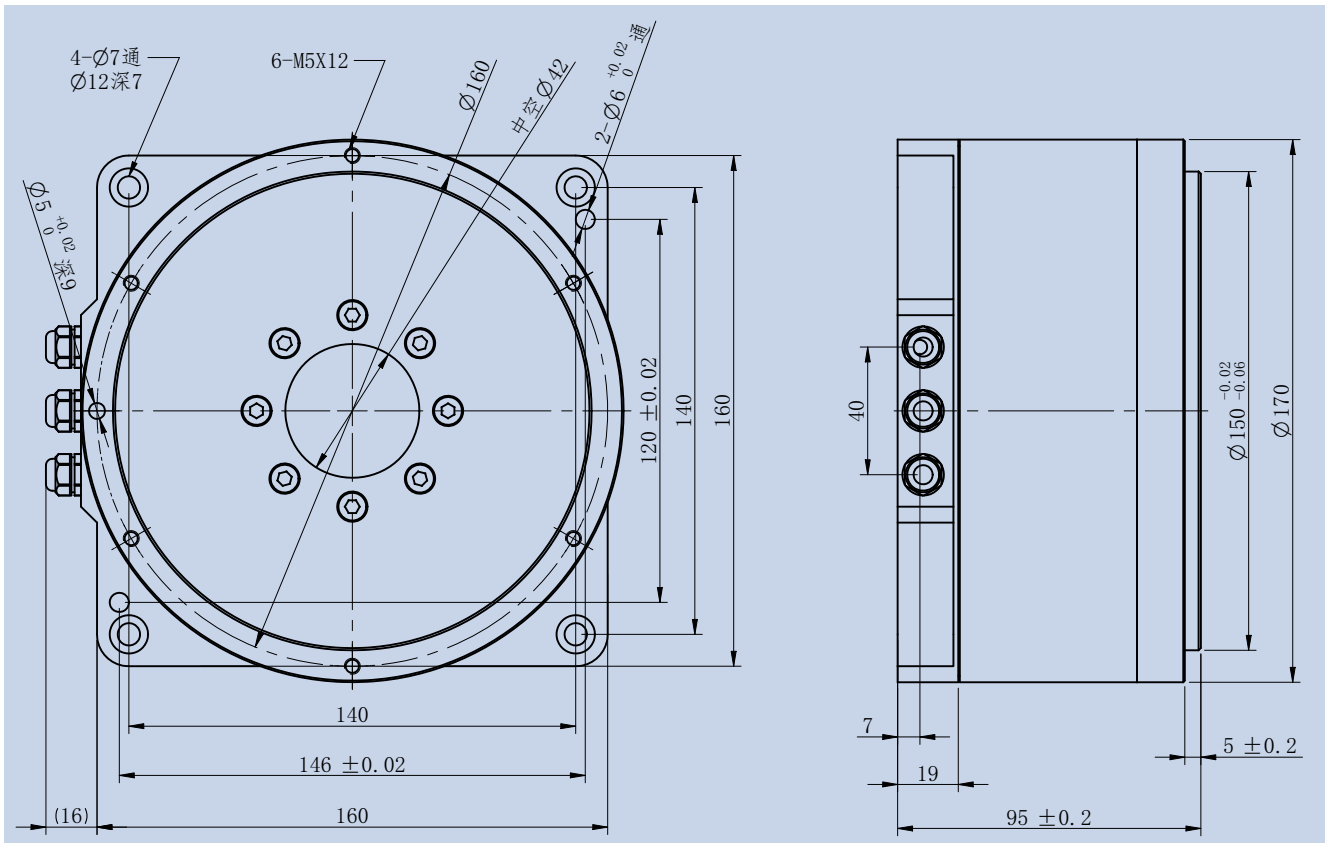

DDW 外转子直驱力矩电机

机械尺寸

DDW-170125-C-FA

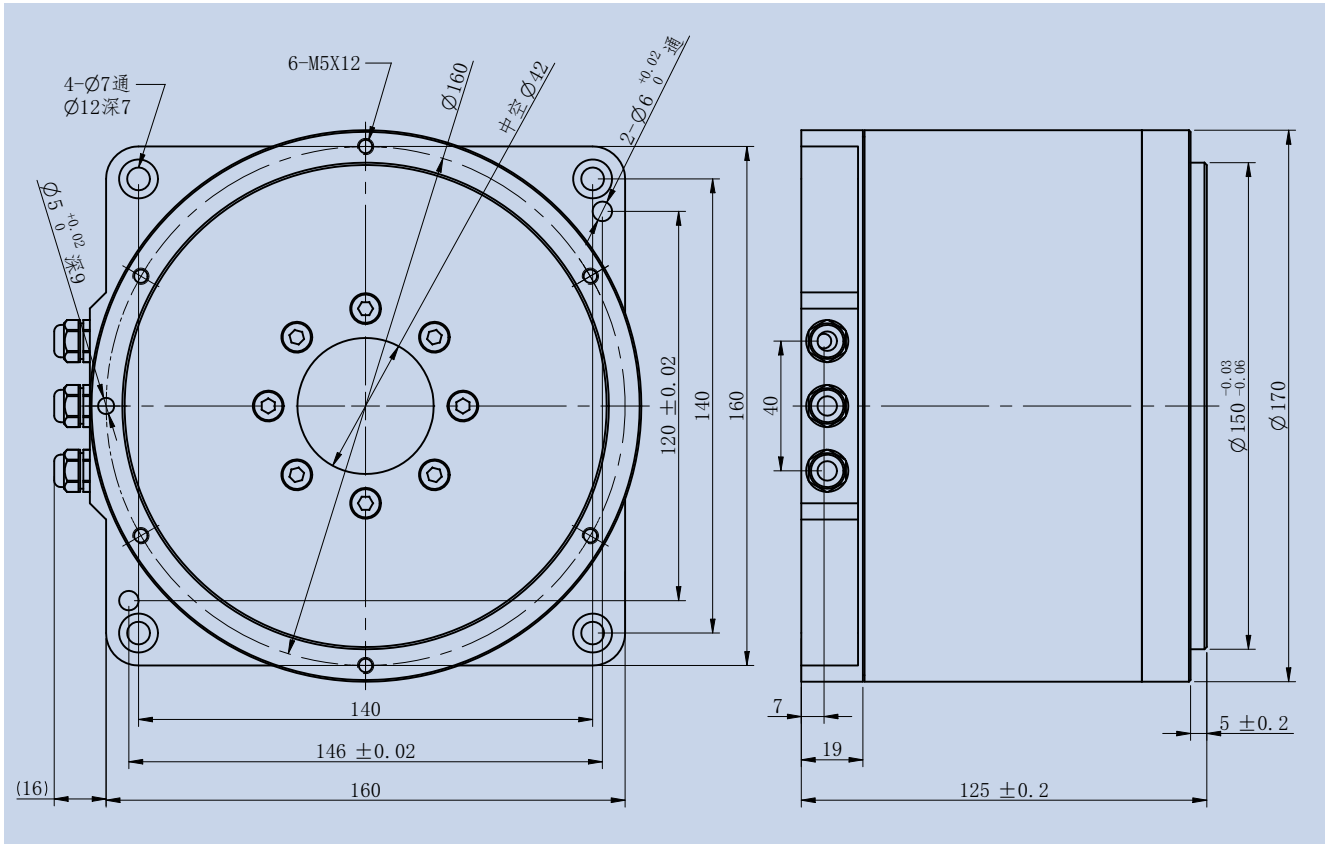

DDW-170130-C-FA

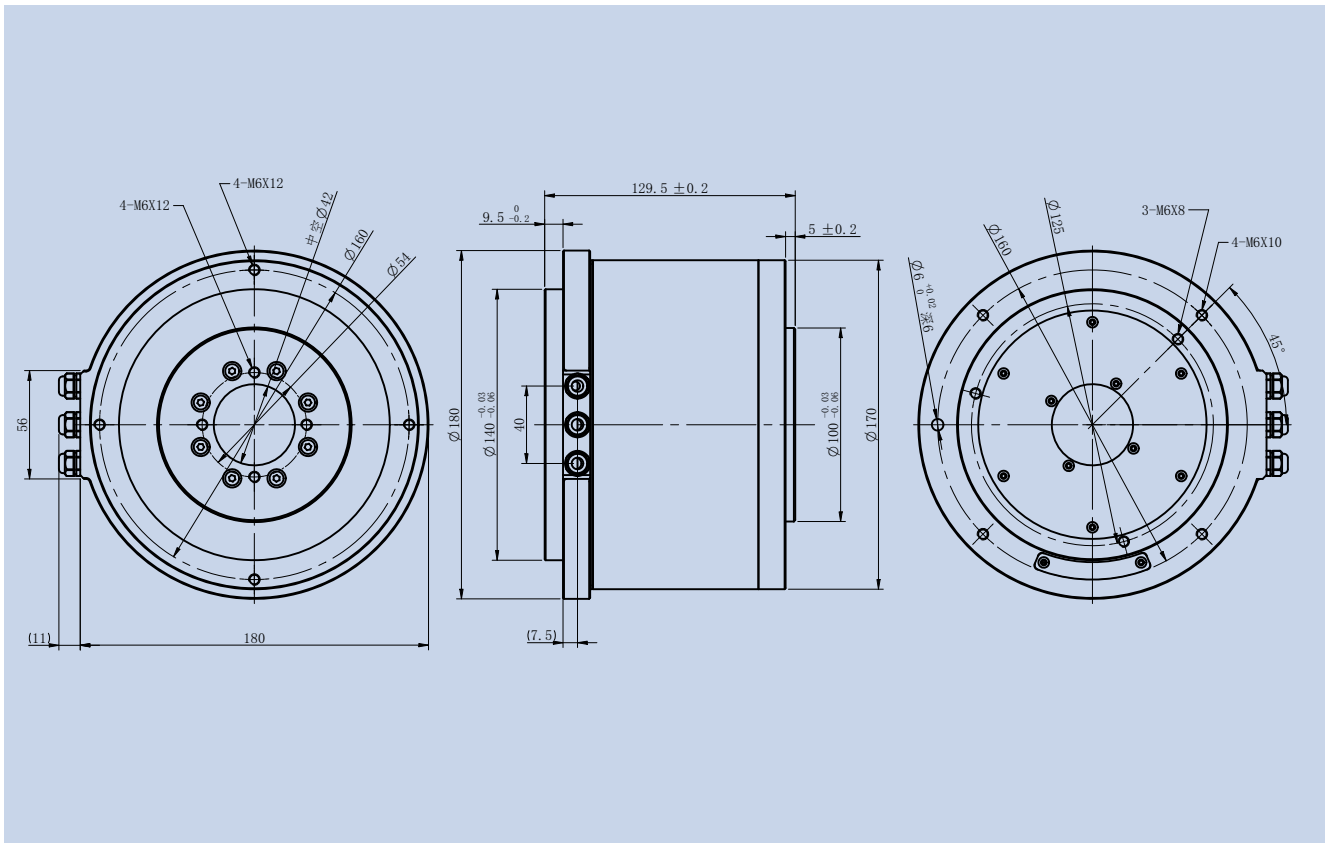

DDW 外转子直驱力矩电机

机械尺寸

DDW-170155-C-FA

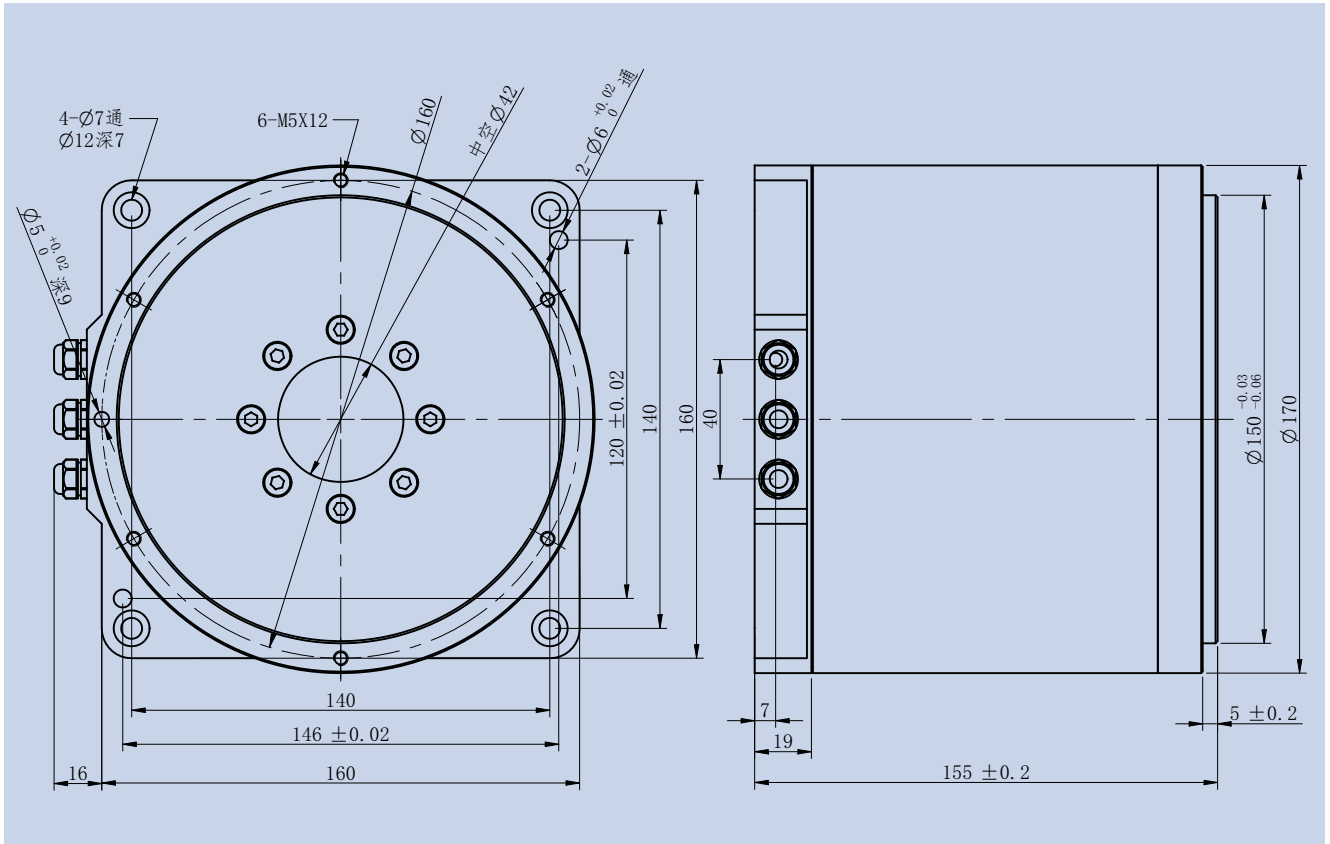

DDW-190100-C-FA

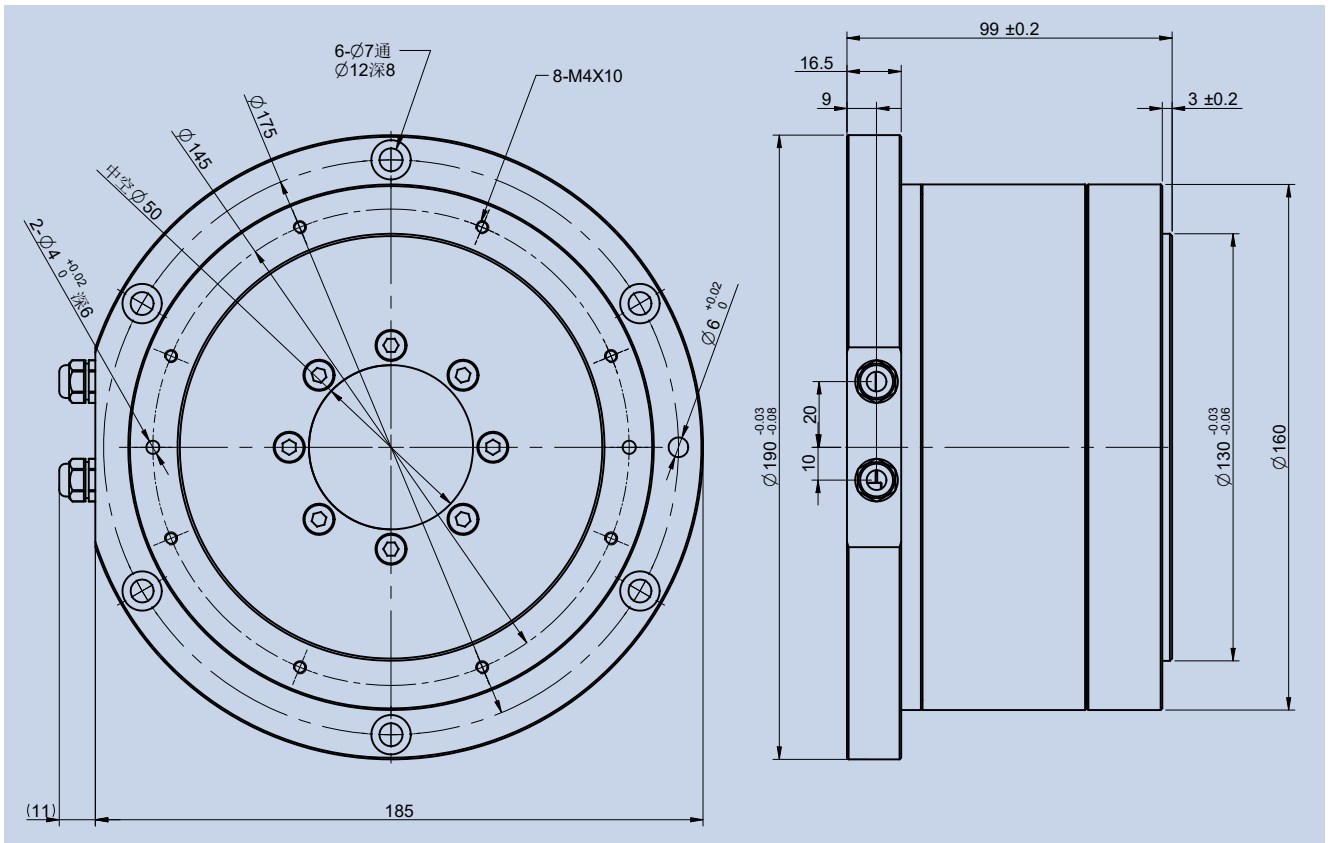

DDW 外转子直驱力矩电机

机械尺寸

DDW-220062-C-FA

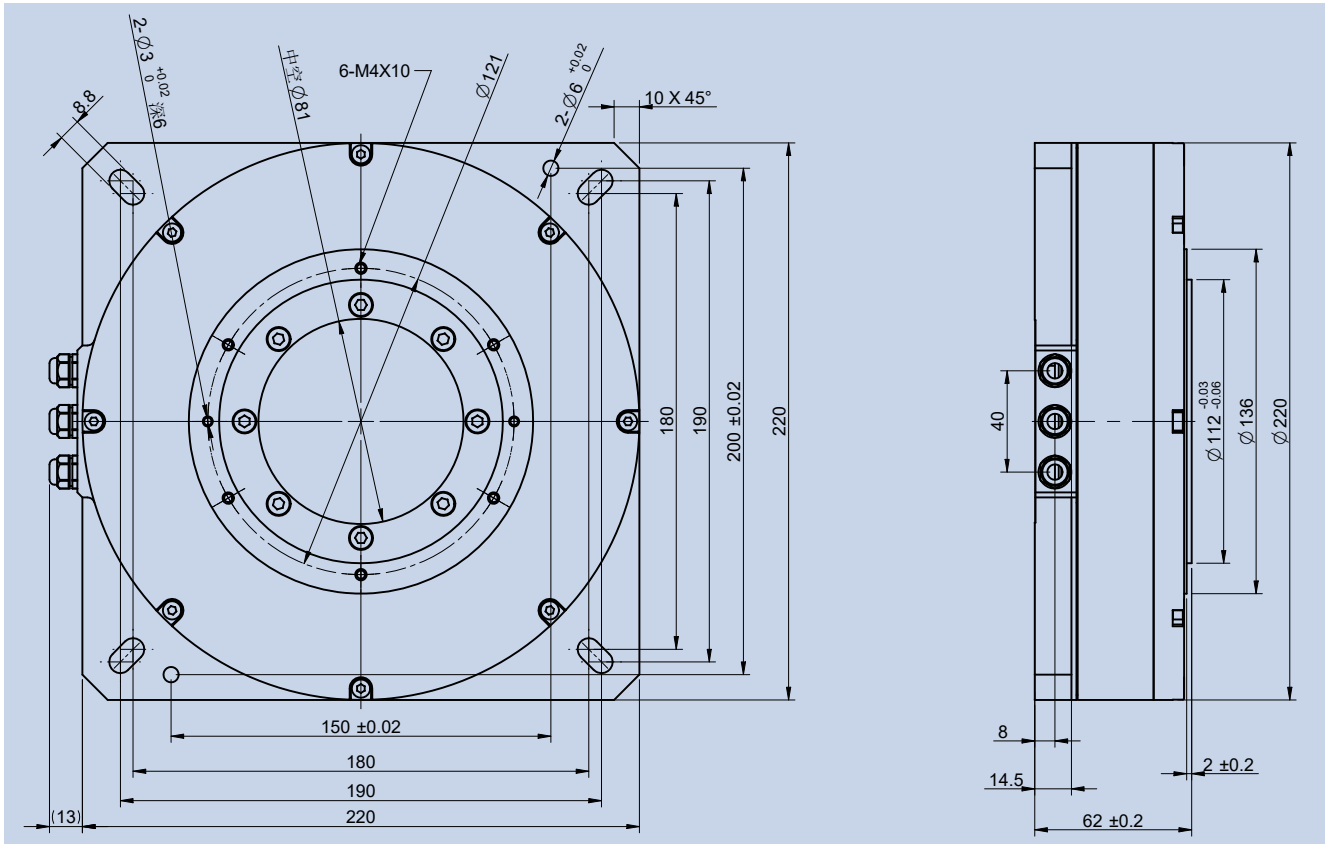

DDW-224042-C-FA

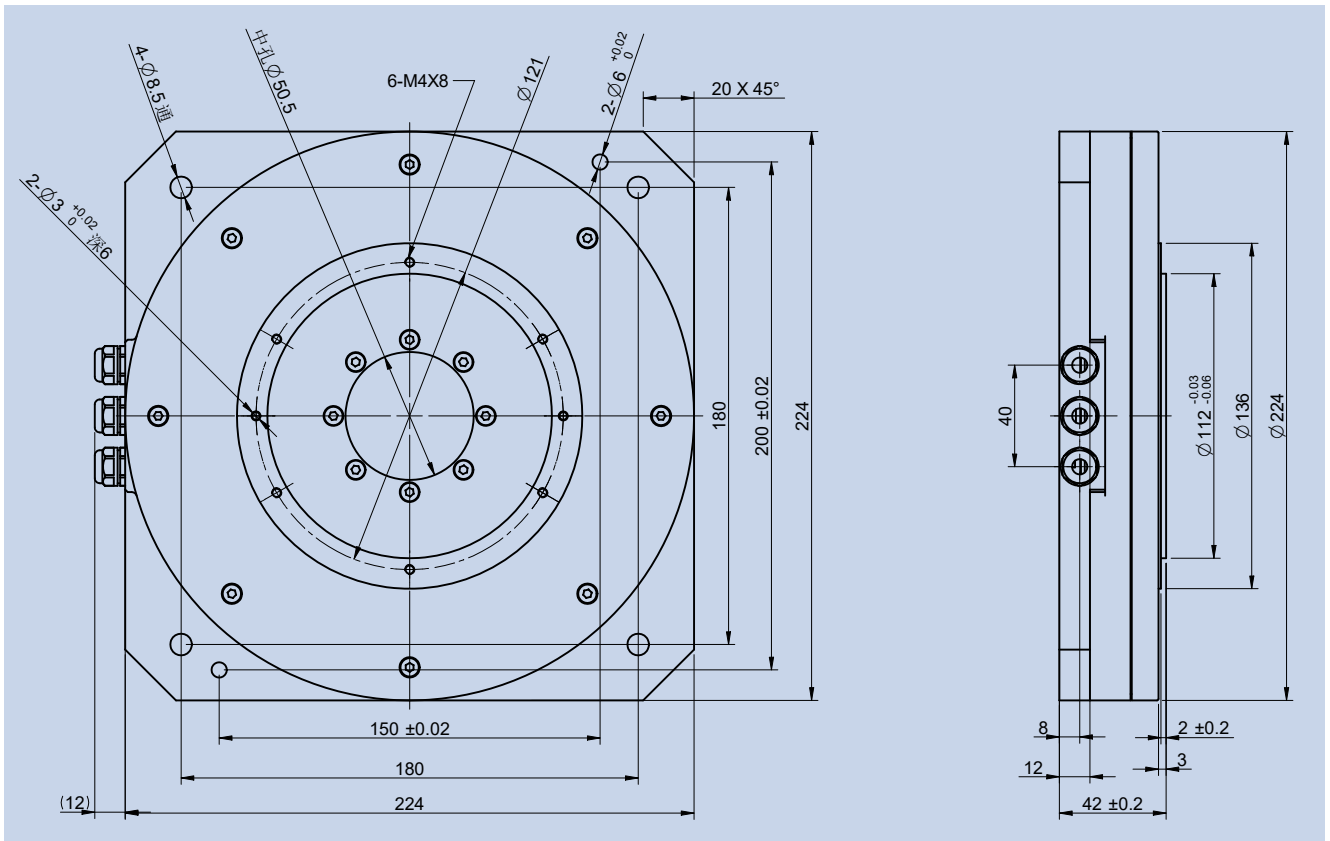

DDW 外转子直驱力矩电机

机械尺寸

DDW-224062-C-FA

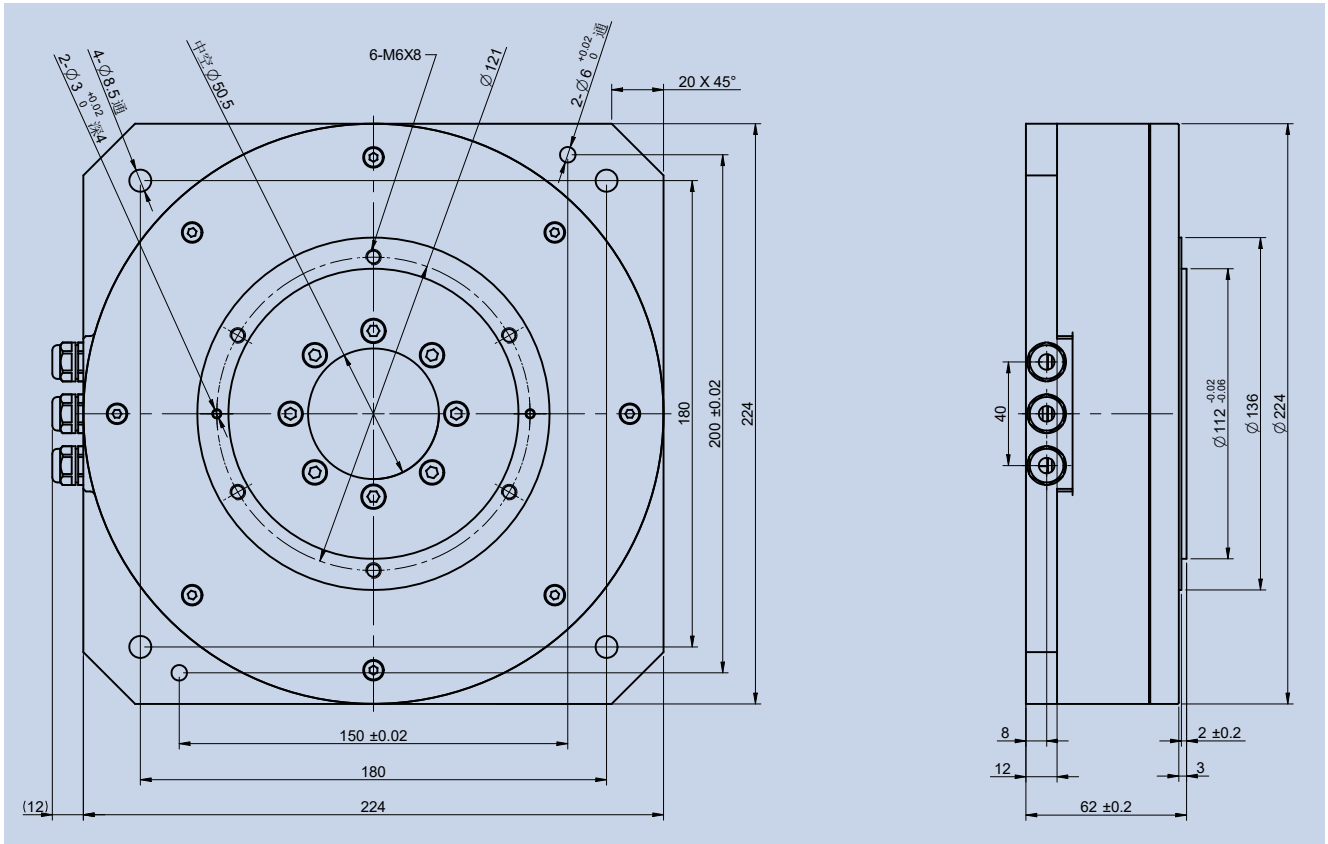

DDW-260035-C-FQL

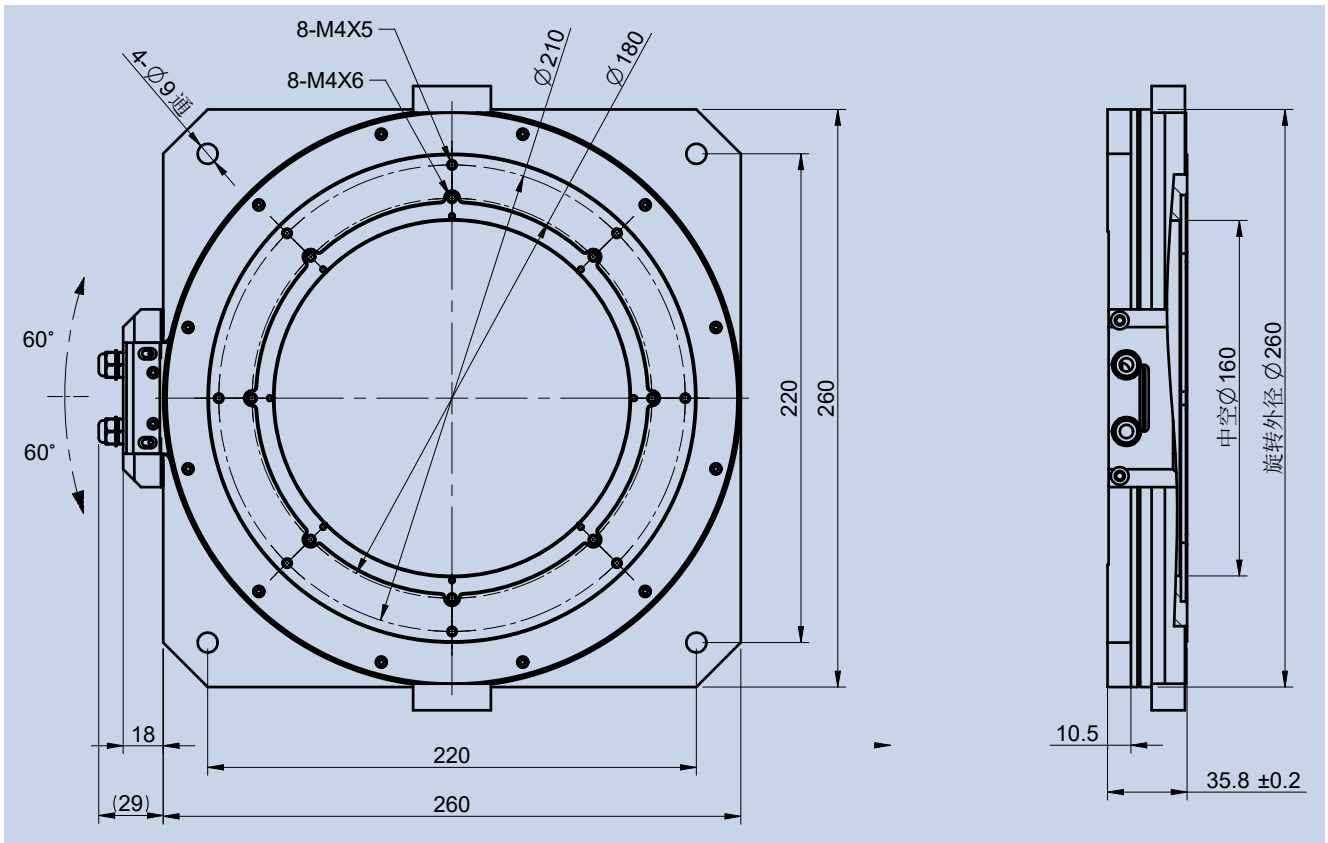

DDW 外转子直驱力矩电机

机械尺寸

DDW-263065-C-FA

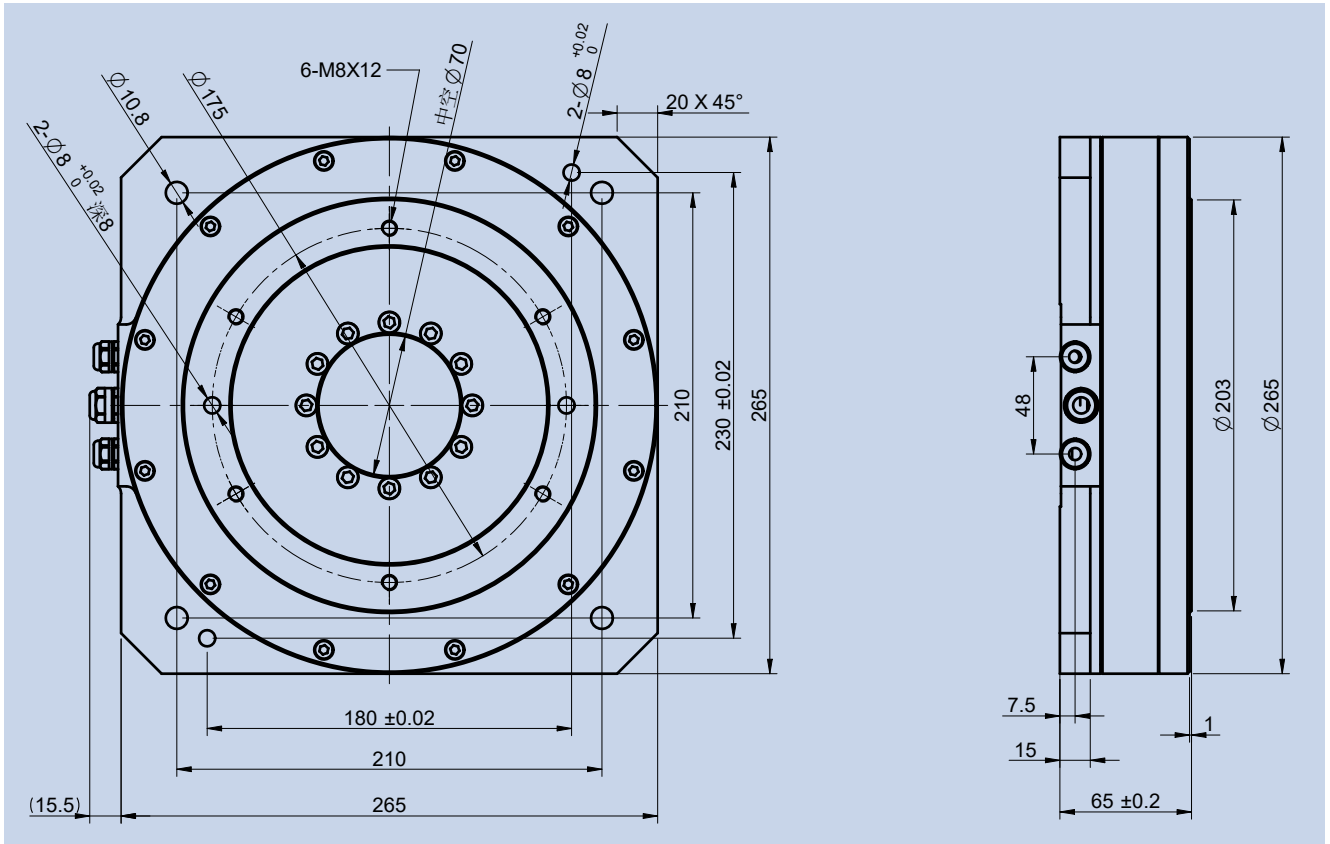

DDW-263095-C-FA

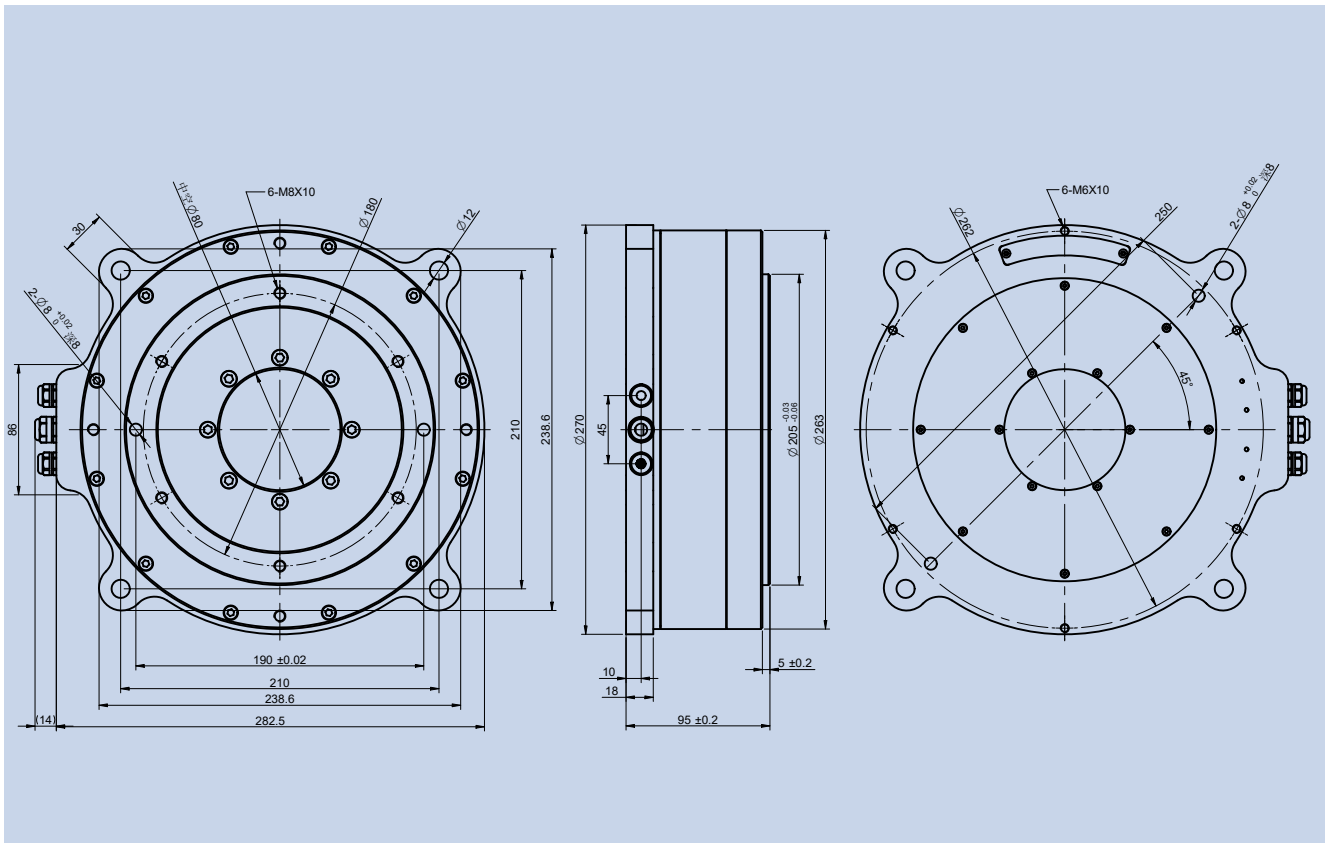

DDW 外转子直驱力矩电机

机械尺寸

DDW-263095-D-FA

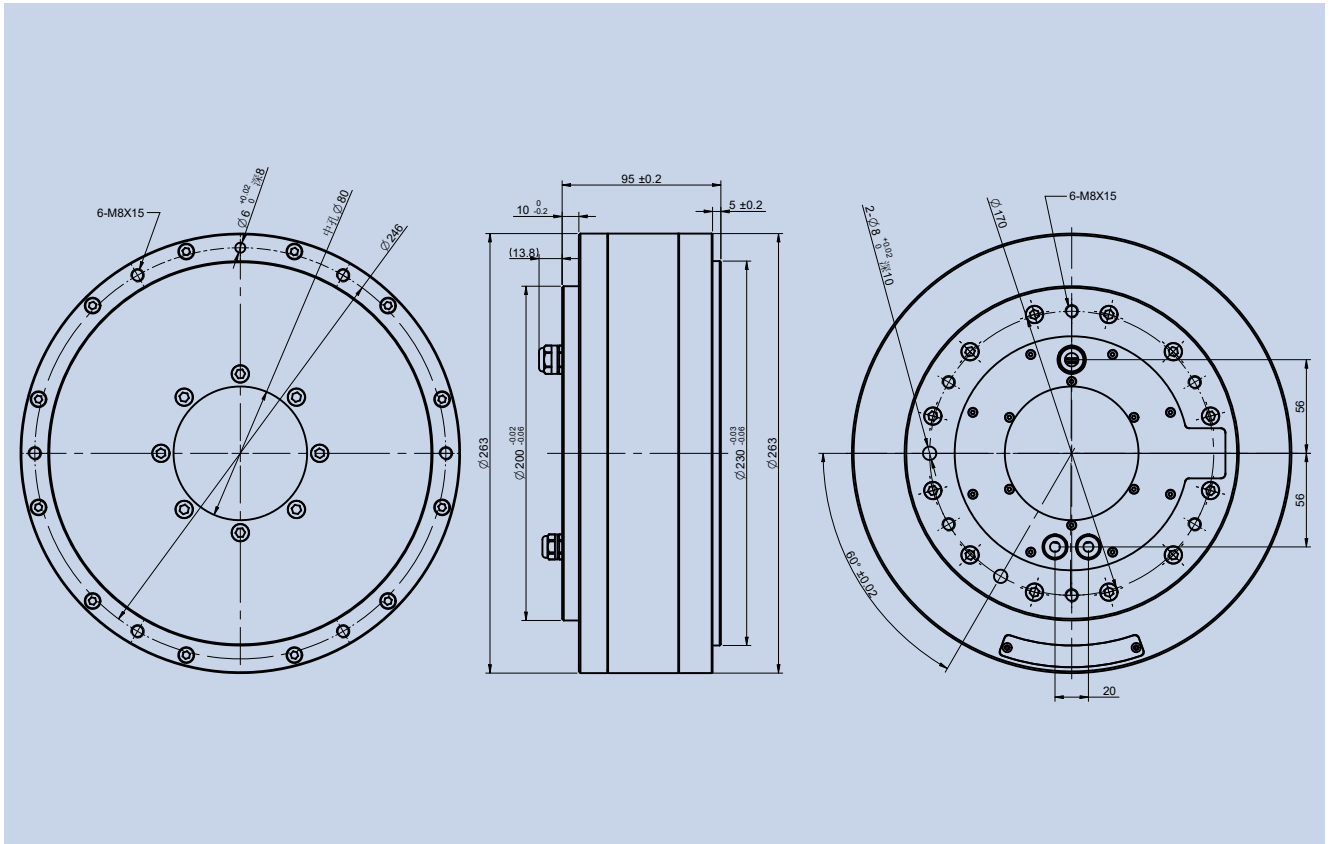

DDW-263112-D-FA

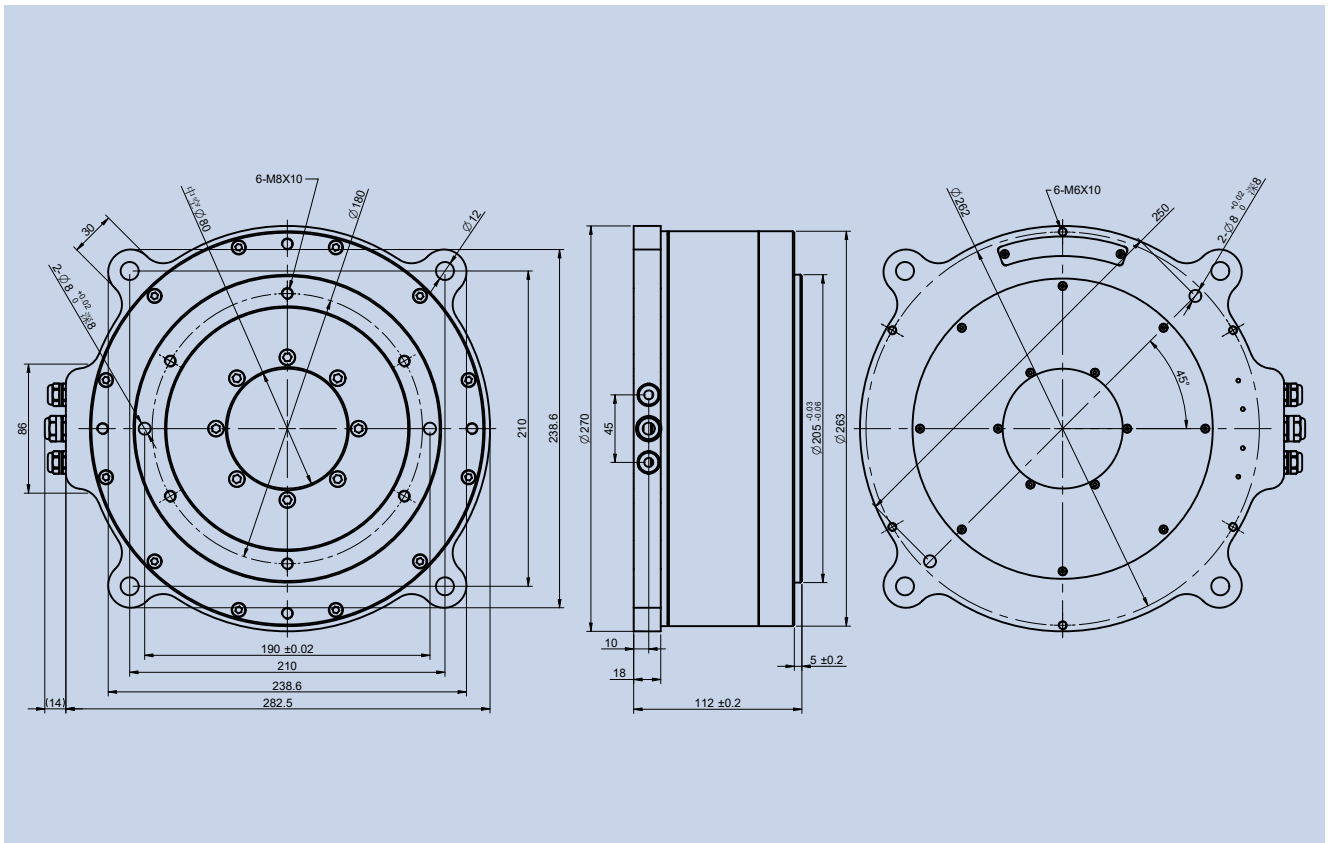

DDW 外转子直驱力矩电机

机械尺寸

DDW-263113-D-FA

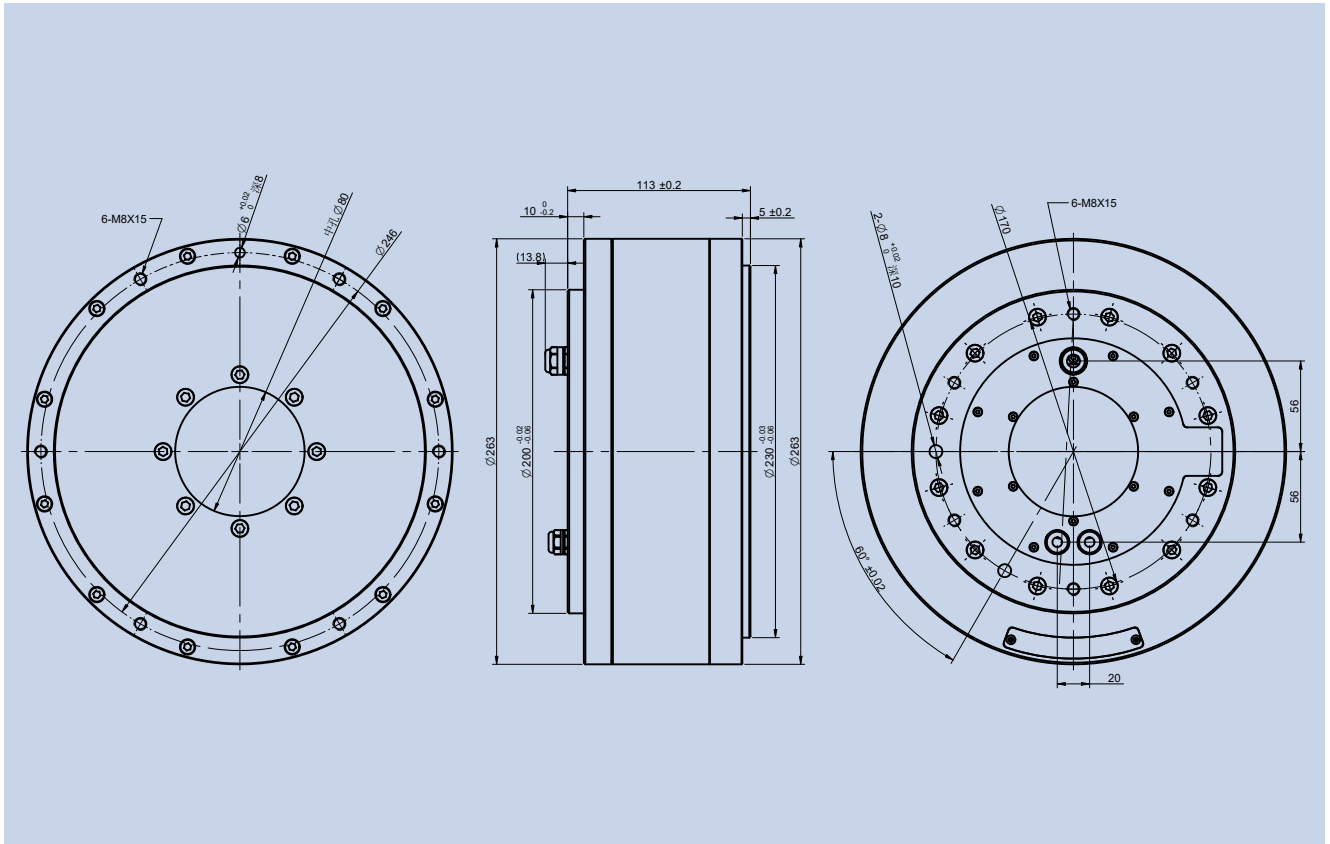

DDW-263134-C-FA2

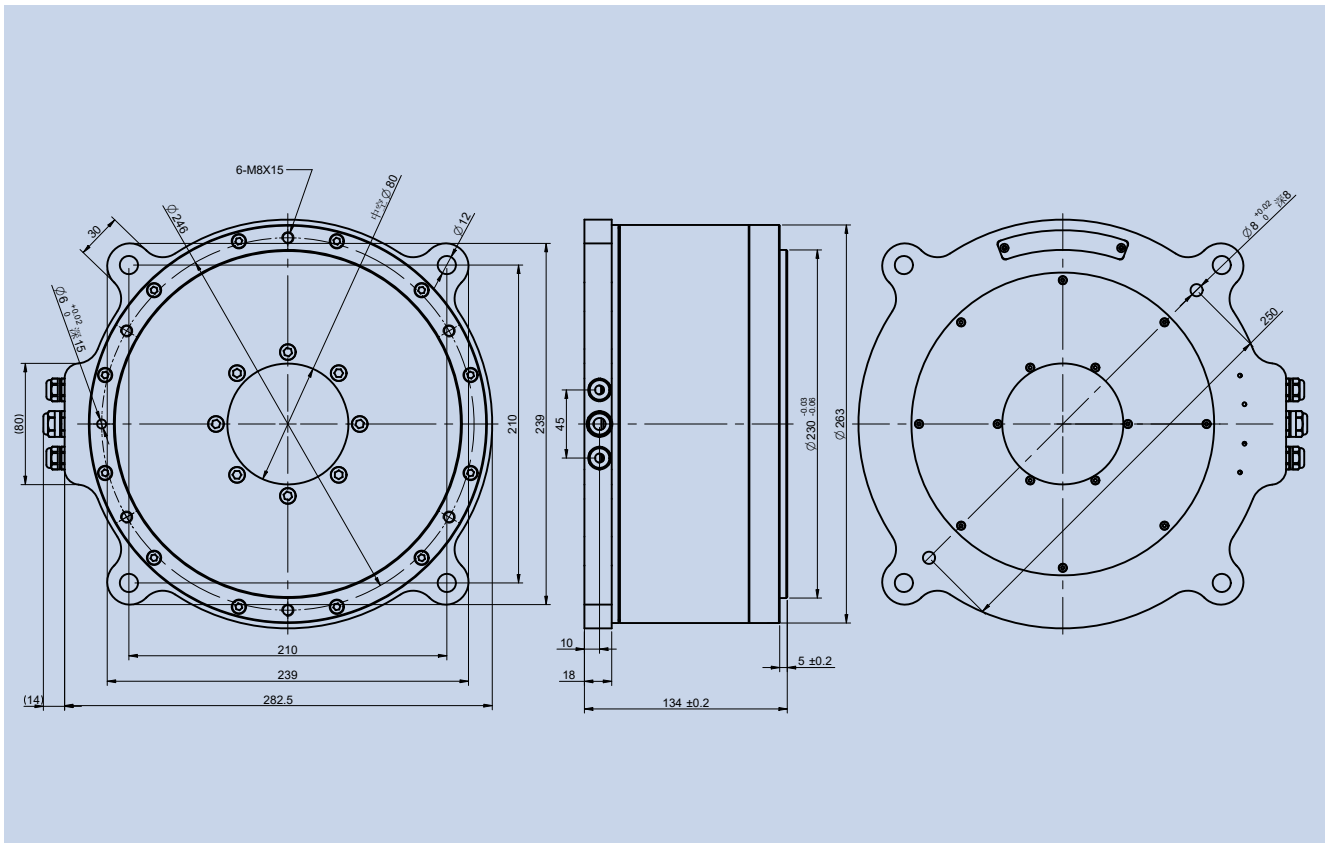

DDW 外转子直驱力矩电机

机械尺寸

DDW-263138-C-FA

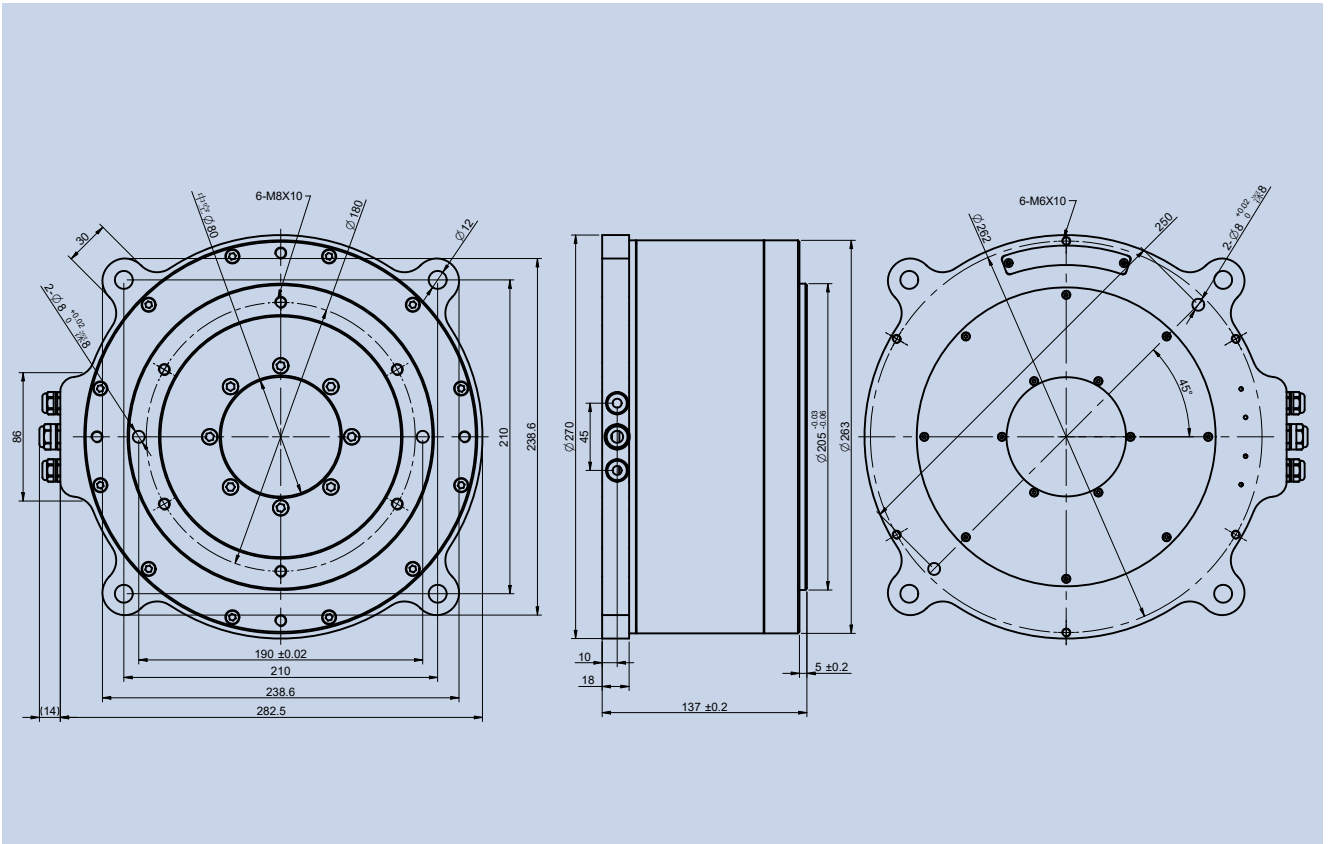

DDW-263138-D-FA

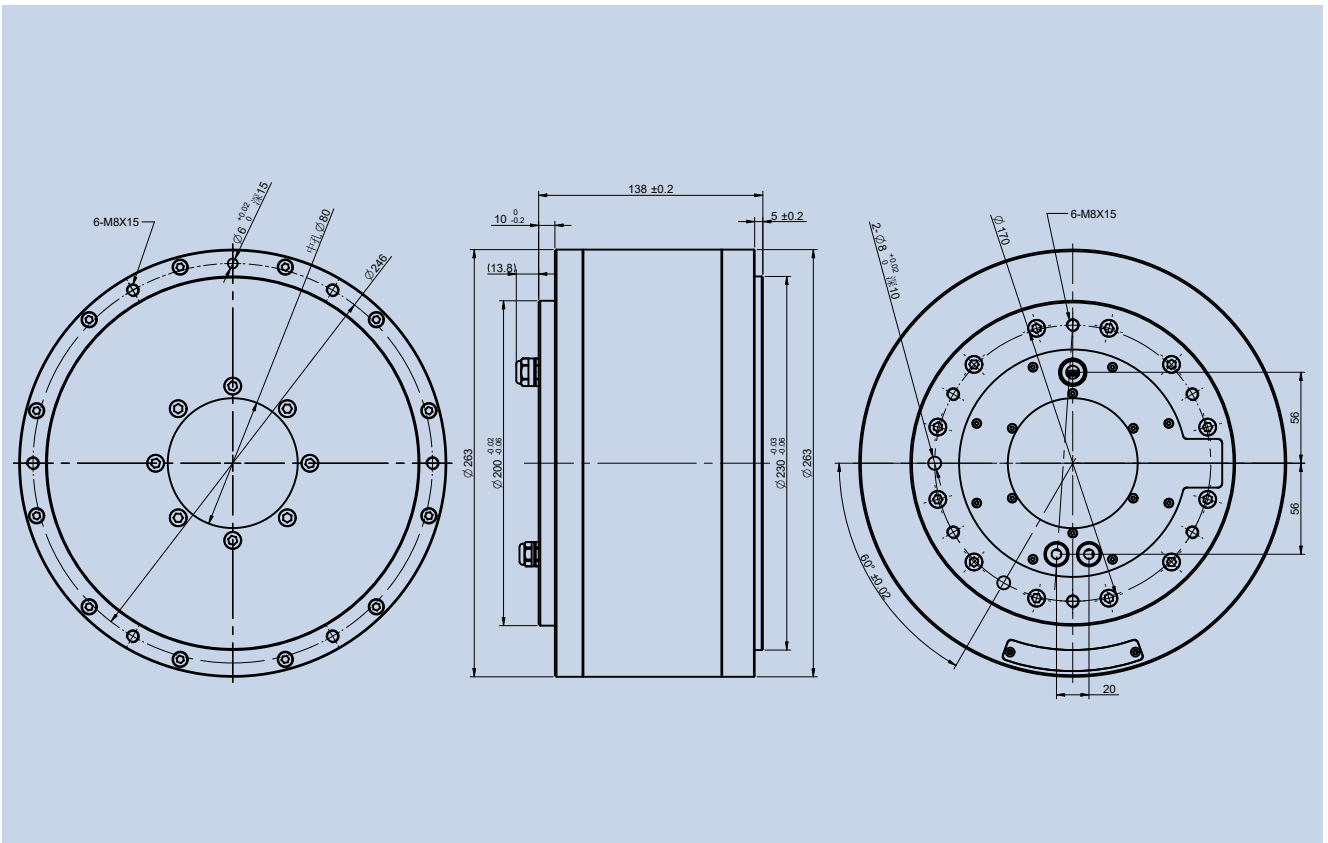

DDW 外转子直驱力矩电机

机械尺寸

DDW-263188-C-FA

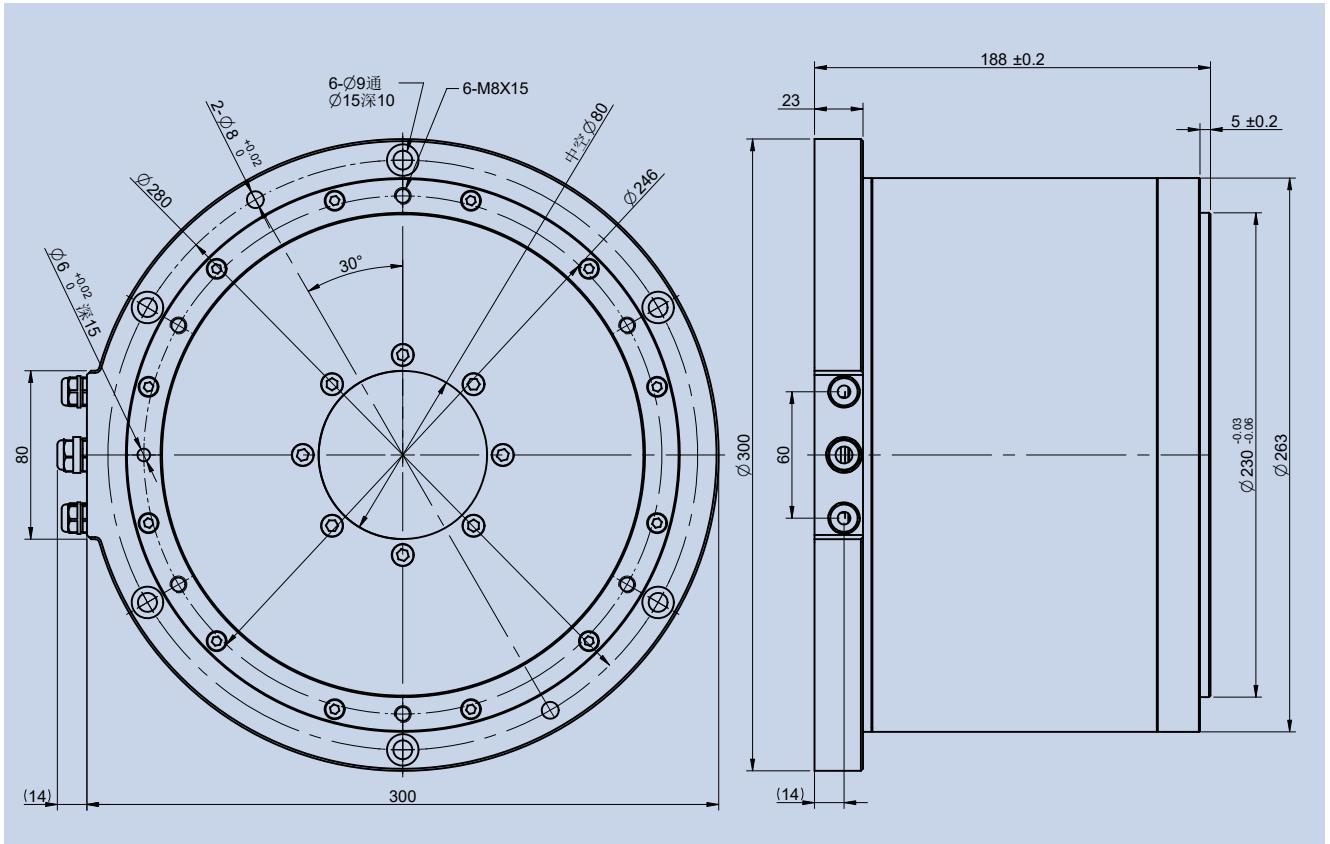

DDW-263188-D-FA

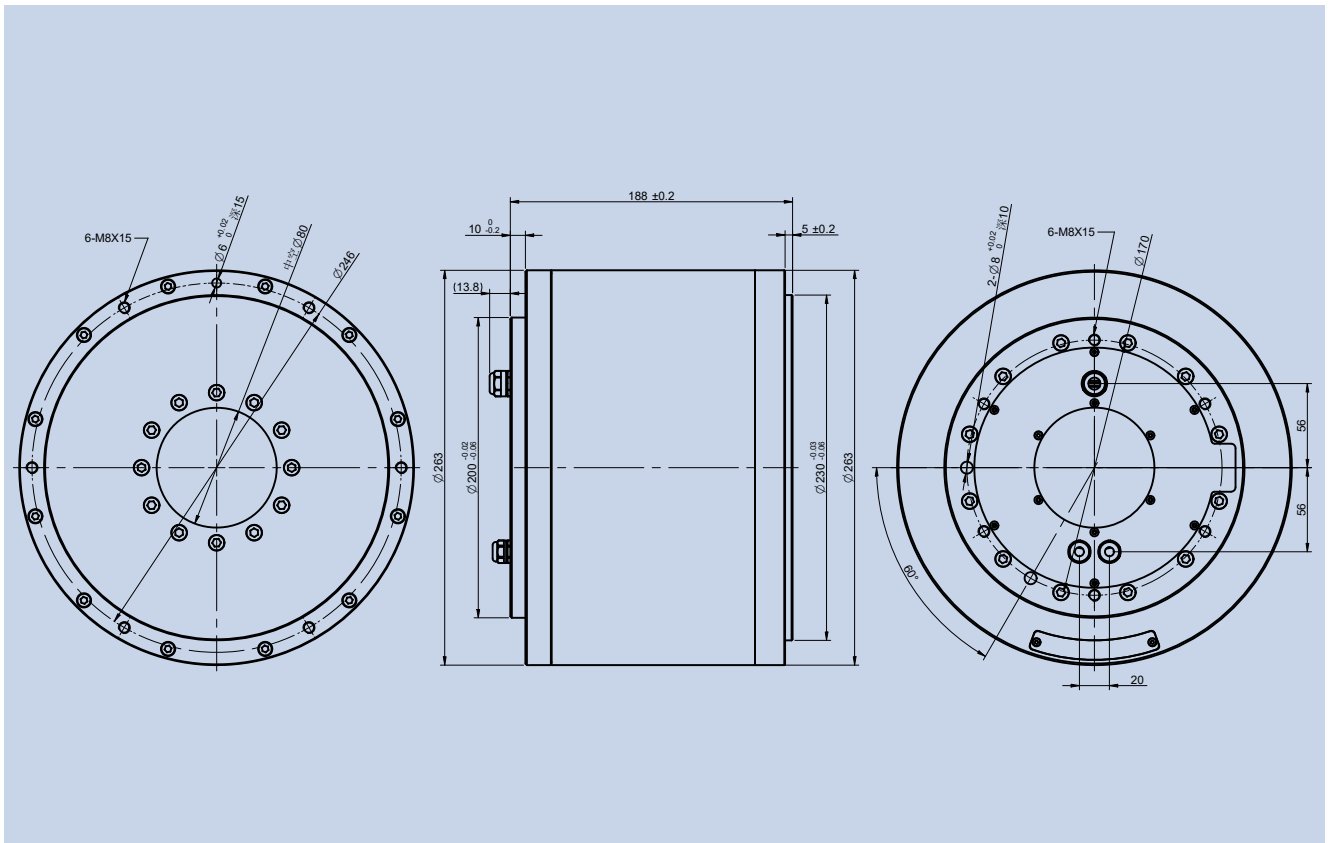

DDW 外转子直驱力矩电机

机械尺寸

DDW-263215-D-FA

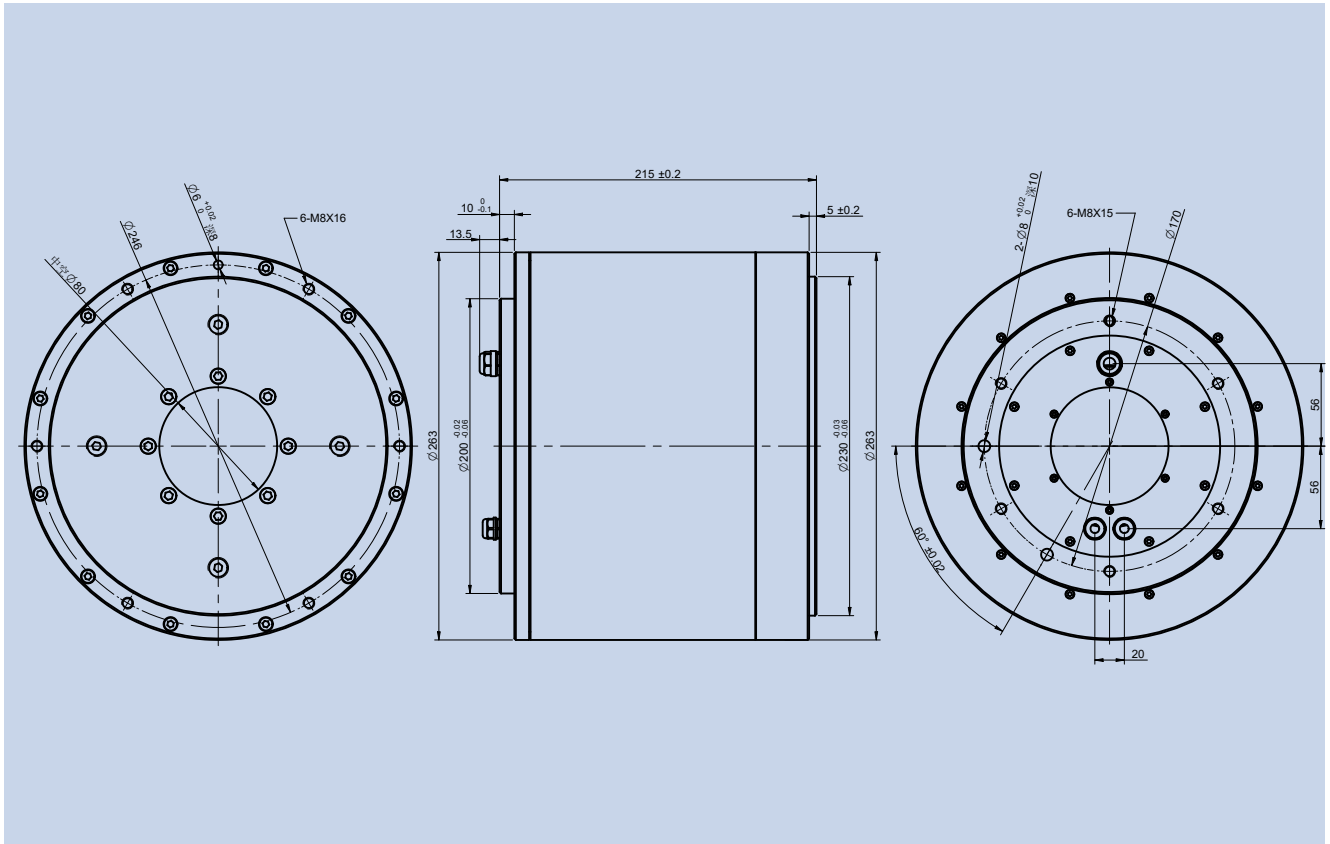

DDW-280145-C-FA

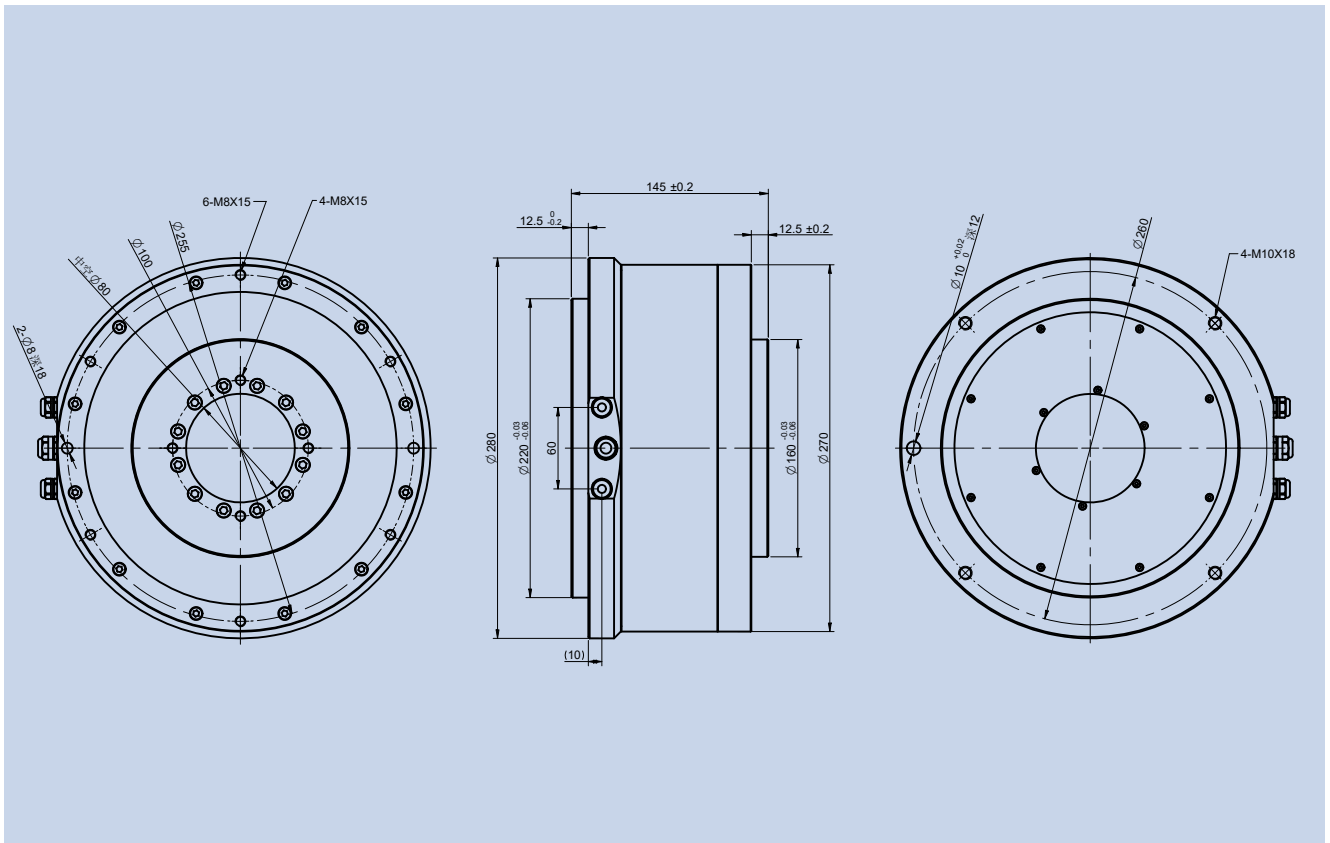

DDW 外转子直驱力矩电机

机械尺寸

DDW-280170-C-FA

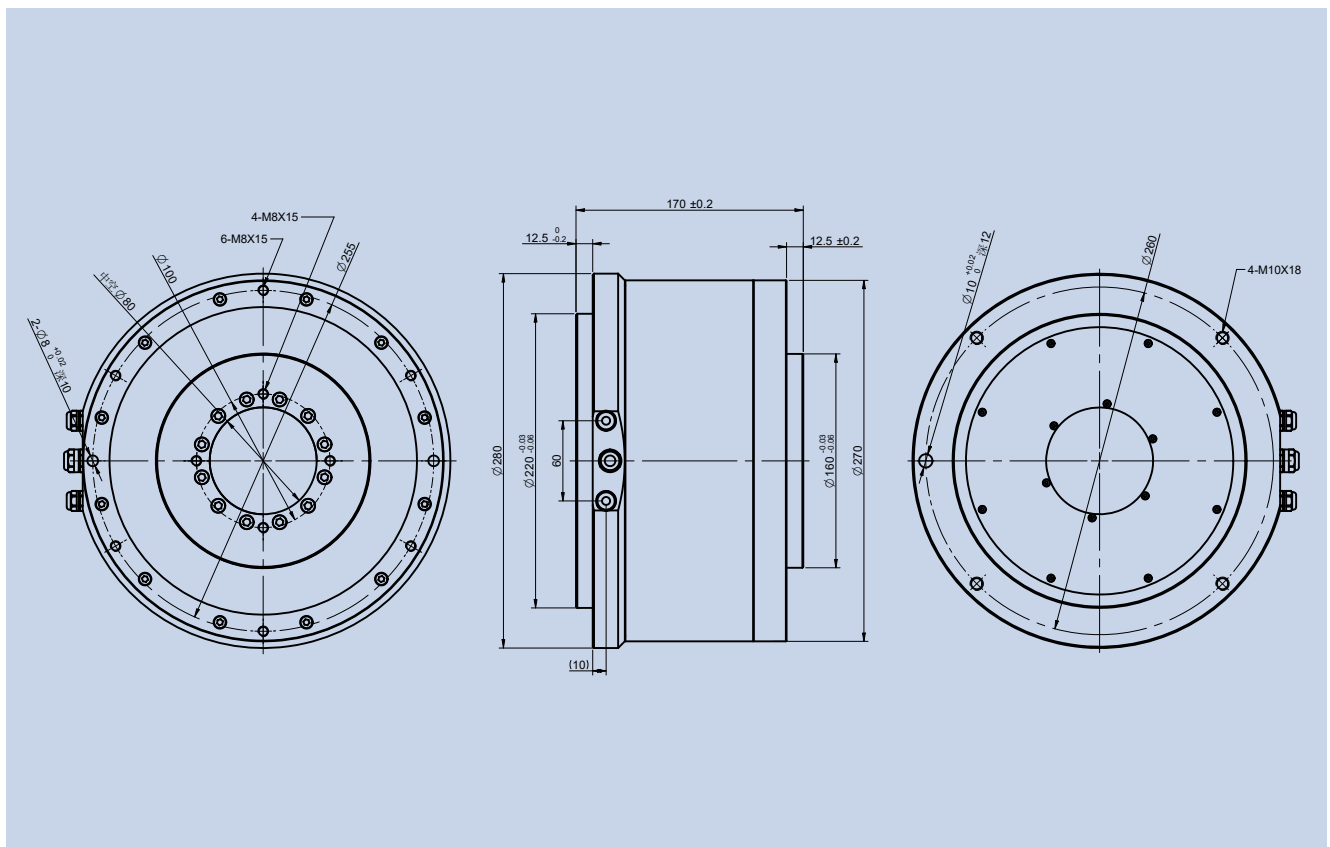

DDW-280231-C-FA

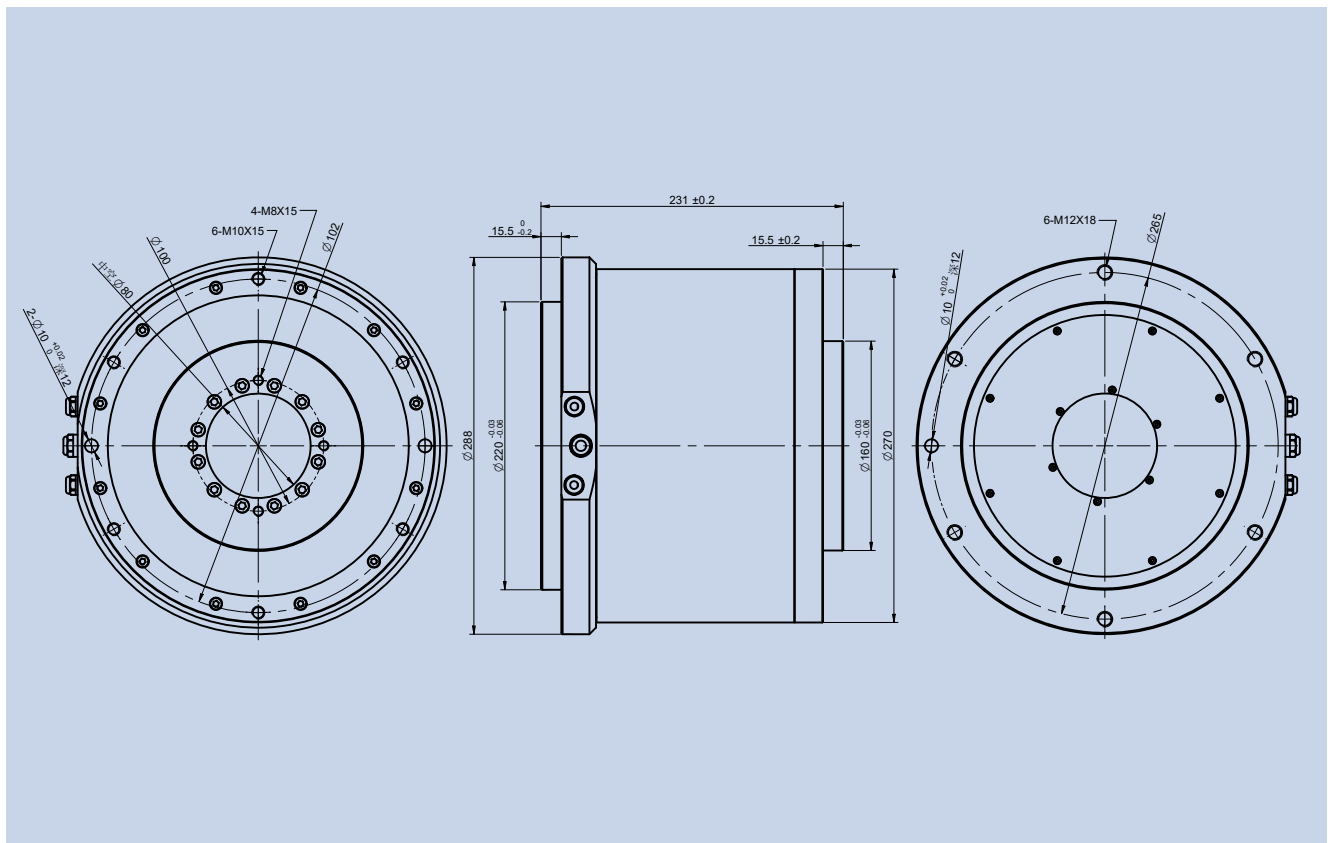

DDW 外转子直驱力矩电机

机械尺寸

DDW-325065-C-FA

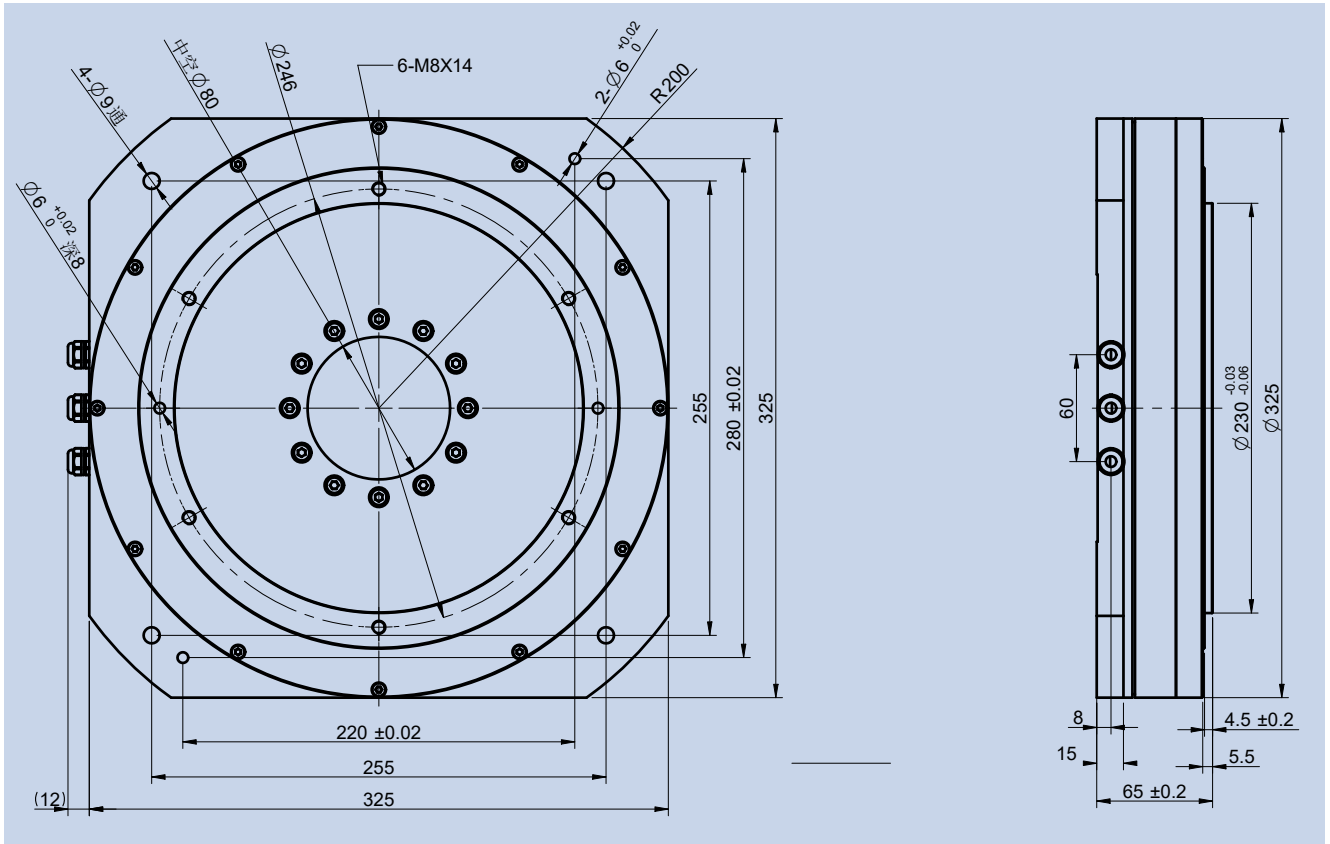

DDW-400052-C-FQL

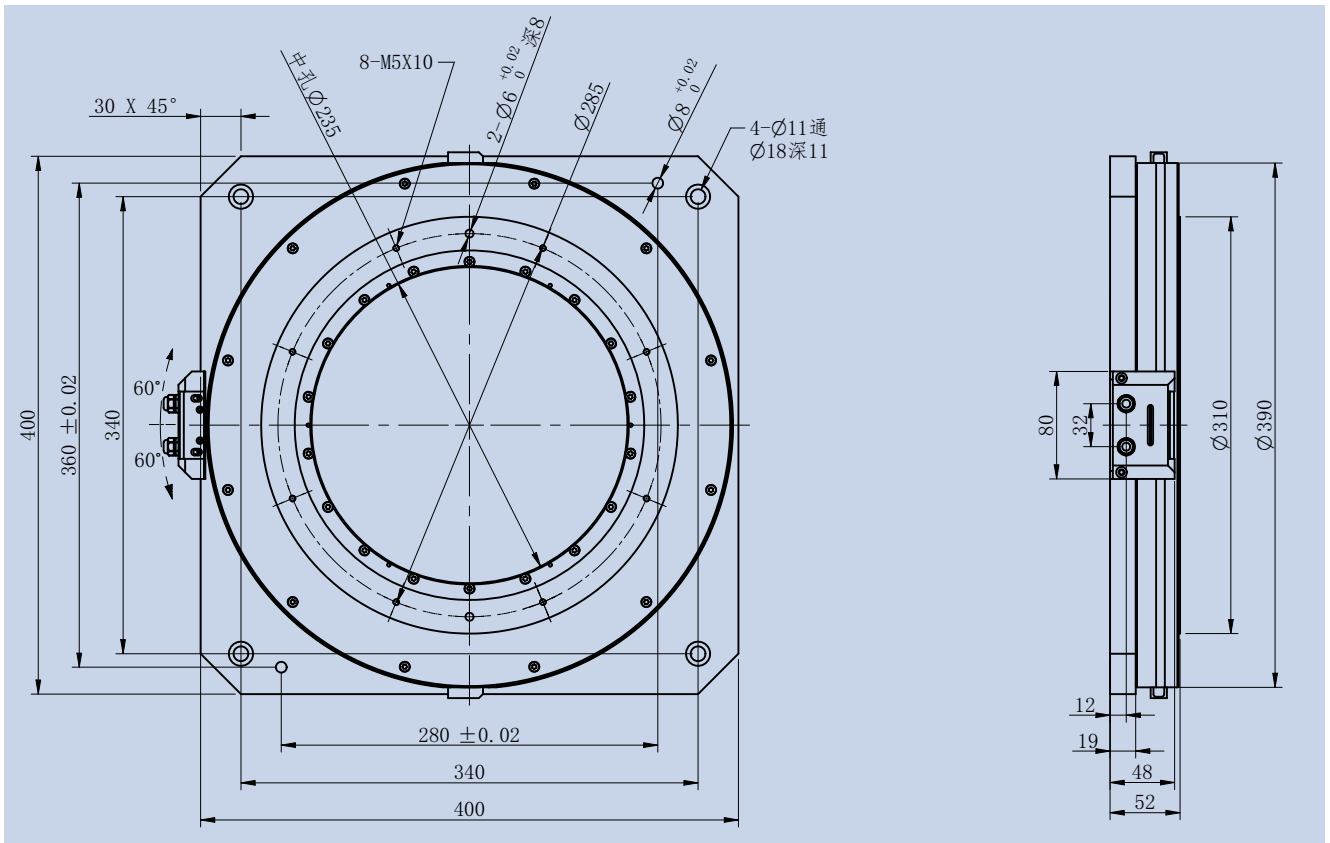

DDW 外转子直驱力矩电机

机械尺寸

DDW-500065-C-FQL

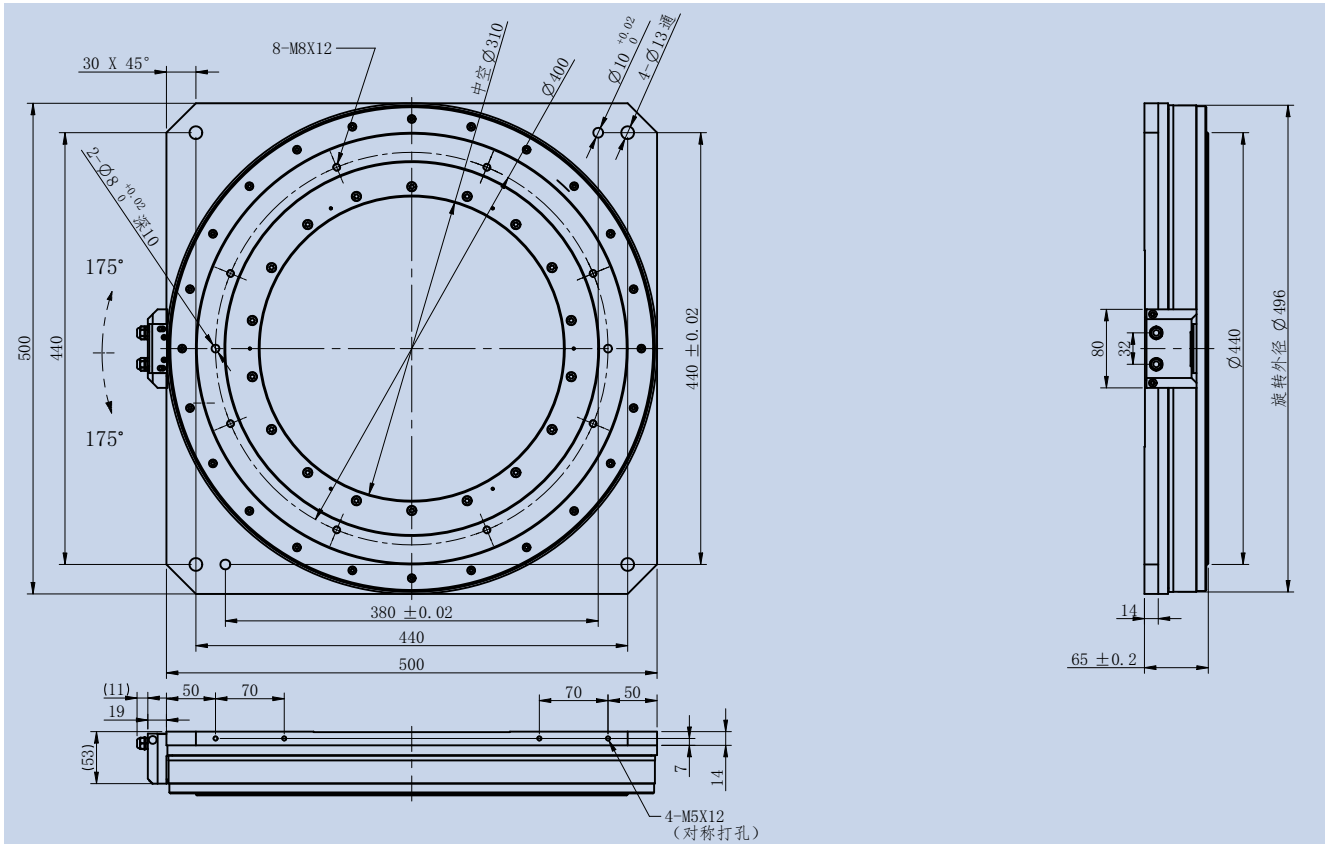

DDW-560067-C-FQL

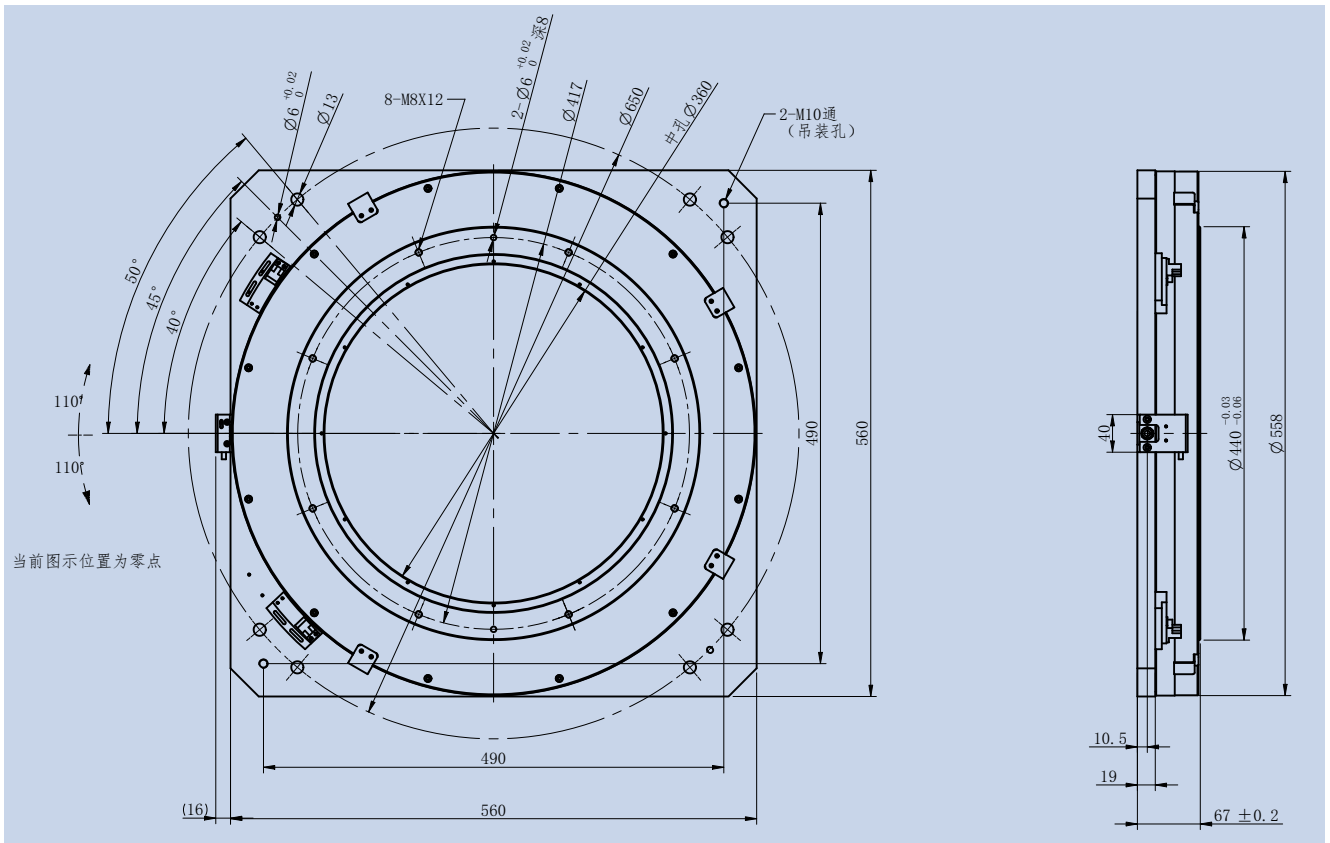

DDN 内转子直驱力矩电机

技术指标

电机型号	通孔直径 mm	连续 转矩 Nm	连续 电流 Arms	最大 转矩 Nm	最大 电流 Arms	最高 转速 rpm	定位 精度 arc sec	重复 精度 arc sec	电机 重量 kg
DDN-062060-C-FA	12	0.3	1.6	1.0	4.8	600	±30	±2.5	0.65
DDN-080050-C-FA-V2	12	0.9	3.2	2.7	9.6	600	±50	±2.5	1.5
DDN-080050-C-FA	12	0.9	3.2	2.7	9.6	600	±50	±2.5	1.5
DDN-080050-D-FA	10	0.9	3.2	2.7	9.6	600	±50	±2.5	1.5
DDN-080067-C-FA-V2	12	1.0	3.2	3.0	9.6	450	±50	±2.5	2.0
DDN-080067-C-FA	12	1.0	3.2	3.0	9.6	450	±30	±1.5	1.8
DDN-080067-D-FA-V2	12	1.0	3.2	3.0	9.6	450	±50	±2.5	2.1
DDN-080067-D-FA	12	1.0	3.2	3.0	9.6	450	±50	±2.5	1.8
DDN-100035-C-FA	8	1.0	1.5	3.0	4.5	350	±50	±2.5	1.1
DDN-120050-C-FA	42	3.5	1.2	10.5	3.5	350	±20	±1.5	2.3
DDN-140129-D-FA	30	18	5.0	47	13.0	250	±20	±1.5	7.3
DDN-140189-D-FA	36	40	8.0	73	14.5	350	±25	±2.5	11.7
DDN-170050-C-FA-V2	35	3.6	3.0	11	9.0	500	±20	±1.5	3.5
DDN-170050-C-FA	35	5.4	3.0	16	9.0	500	±20	±1.5	3.9
DDN-170075-C-FA	42	18.8	3.5	50	10.5	350	±20	±1.5	6.0
DDN-170080-C-FES-V2	-	8.3	15.0	17	30.0	200	±50	±5.0	5.6
DDN-170080-C-FES	-	9.9	3.0	30	9.0	250	±30	±2.5	5.6
DDN-180055-C-FA	40	14	4.5	42	13.5	250	±20	±1.5	5.4
DDN-180095-C-FA	40	25.2	4.5	76	13.5	300	±20	±1.5	9.1
DDN-180098-D-FA	40	27.4	3.7	83	11.2	300	±20	±1.5	9.4
DDN-180125-C-FA	40	40	4.5	120	13.5	250	±20	±1.5	13
DDN-220070-C-FA	100	10	5.5	30	16.5	120	±15	±1.5	6.5
DDN-220123-C-FA	50	35	5.5	150	16.5	200	±20	±1.5	20
DDN-220168-C-FA	50	88.6	5.7	266	17.5	150	±30	±1.5	24.7
DDN-224042-C-FA-V2	50.5	10	2.3	30	7.0	250	±20	±1.5	9.4
DDN-224042-C-FA	50.5	10	2.3	30	7.0	250	±20	±1.5	6.3
DDN-224065-C-FA	50.5	20	2.3	60	7.0	150	±20	±1.5	11.5
DDN-260208-D-FA2-W	50	230	23.0	350	35.0	250	±10	±1.0	42.5
DDN-380230-C-FL2-W	100	600	32.0	1400	75.0	150	±15	±1.5	109
DDN-390245-C-FL	70	280	5.0	1400	25.0	50	±30	±2.5	158
DDN-408077-C-FA	70	150	5.0	300	10.2	300	±20	±1.5	36
DDN-408077-C-FL	24	150	5.0	300	10.2	300	±30	±2.5	61
DDN-408077-D-FA	65	150	5.0	500	10.2	300	±20	±1.5	31.5
DDN-408102-C-FA	80	250	4.5	500	13.5	80	±20	±1.5	46
DDN-408102-C-FL	70	250	4.5	500	13.5	80	±30	±2.5	76
DDN-408102-D-FA	85	250	4.5	190	13.5	80	±30	±2.5	46
DDN-408165-C-FA-V2	80	500	8.6	190	25.8	60	±15	±1.5	110
DDN-408185-C-FA-V2	80	500	8.6	500	25.8	60	±15	±1.5	110
DDN-408165-D-FA-V2	65	500	8.6	90	25.8	60	±15	±1.5	94
DDN-408180-C-FA-V2	80	500	8.6	80	25.8	60	±15	±1.5	130
DDN-408180-C-FL-V2	100	500	8.6	86	25.8	60	±20	±1.5	130
DDN-670179-C-FLJ-V2	200	1380	28.0	125	50.0	50	±20	±1.5	260

DDN 内转子直驱力矩电机

机械尺寸

DDN-062060-C-FA

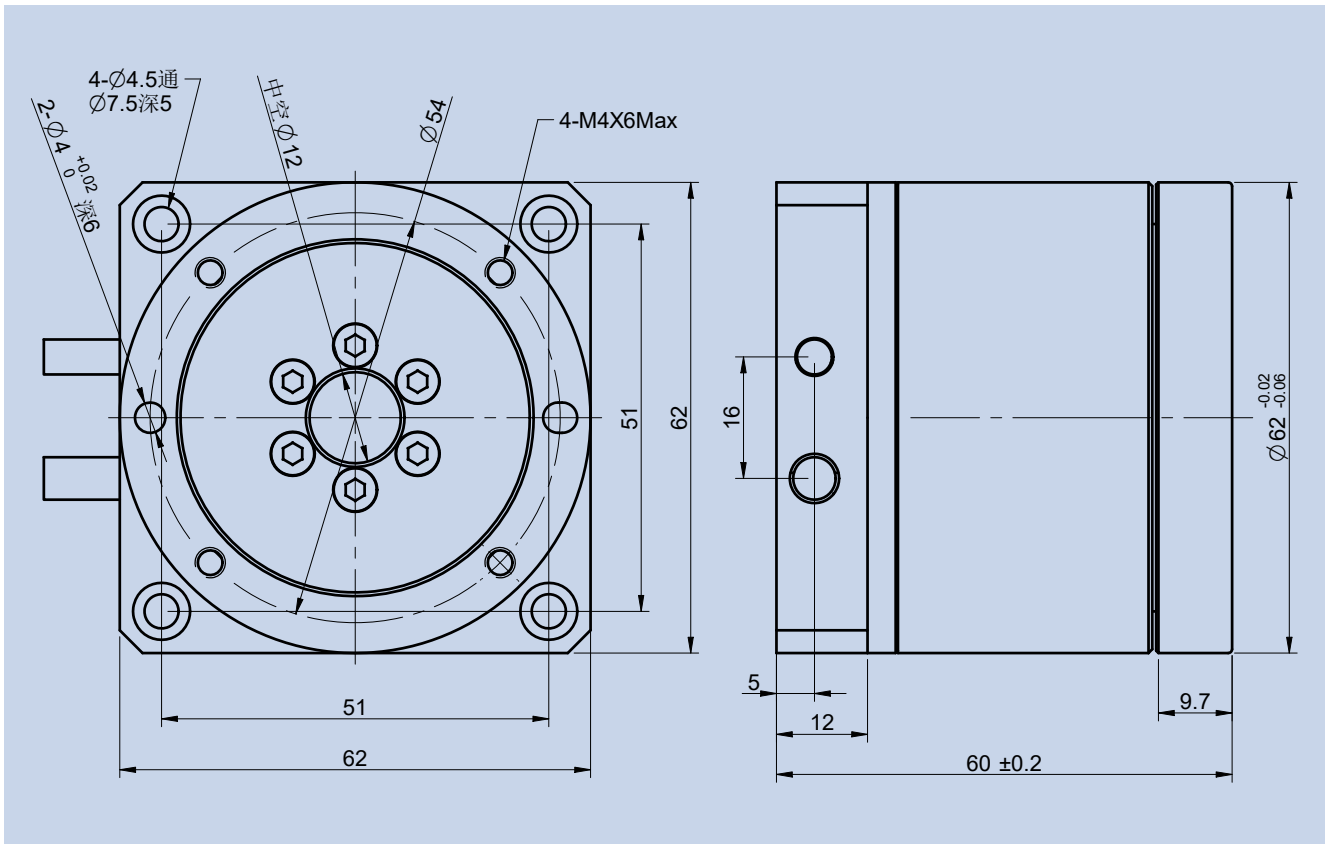

DDN-080050-C-FA

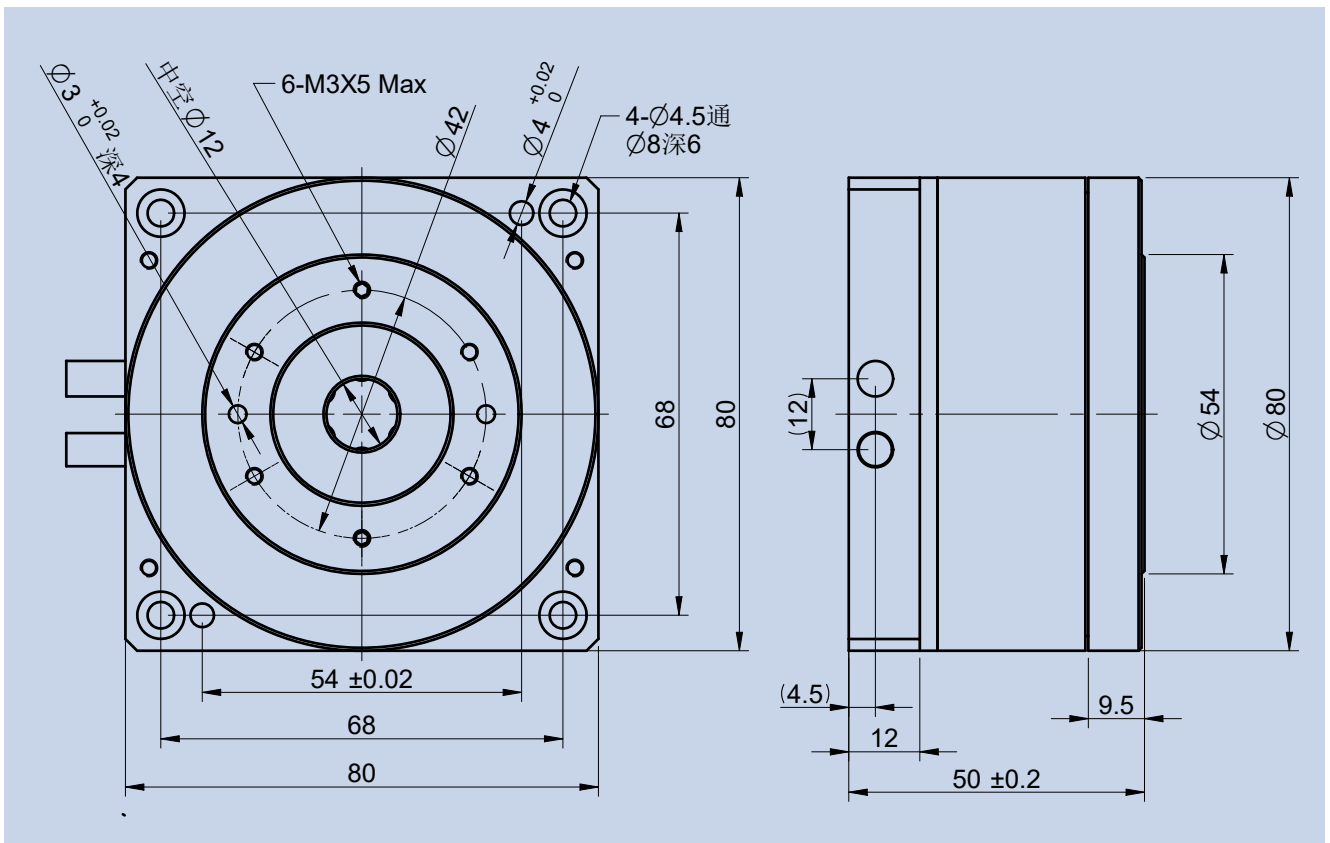

DDN 内转子直驱力矩电机

机械尺寸

DDN-080020-C-FA-V2

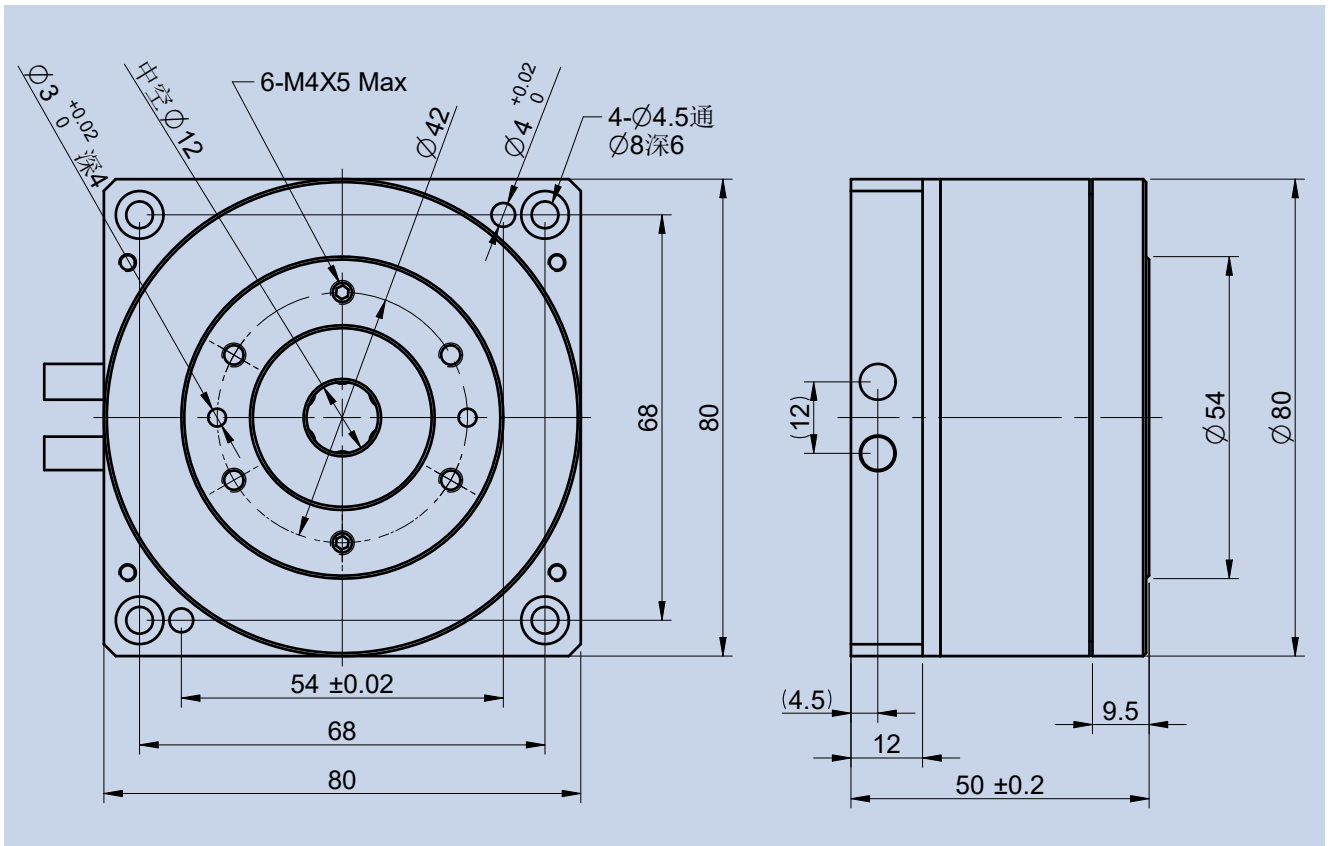

DDN-080050-D-FA

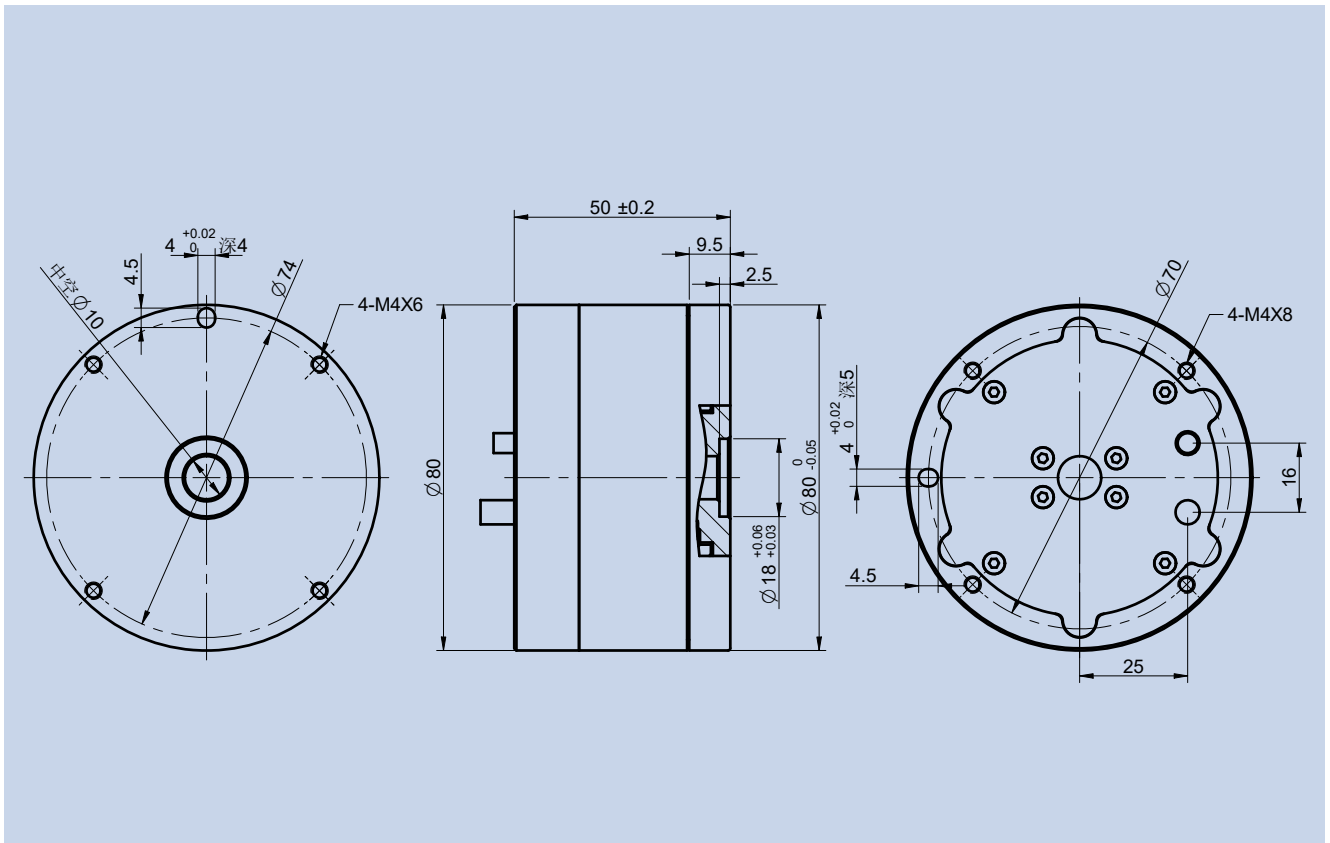

DDN 内转子直驱力矩电机

机械尺寸

DDN-080067-D-FA

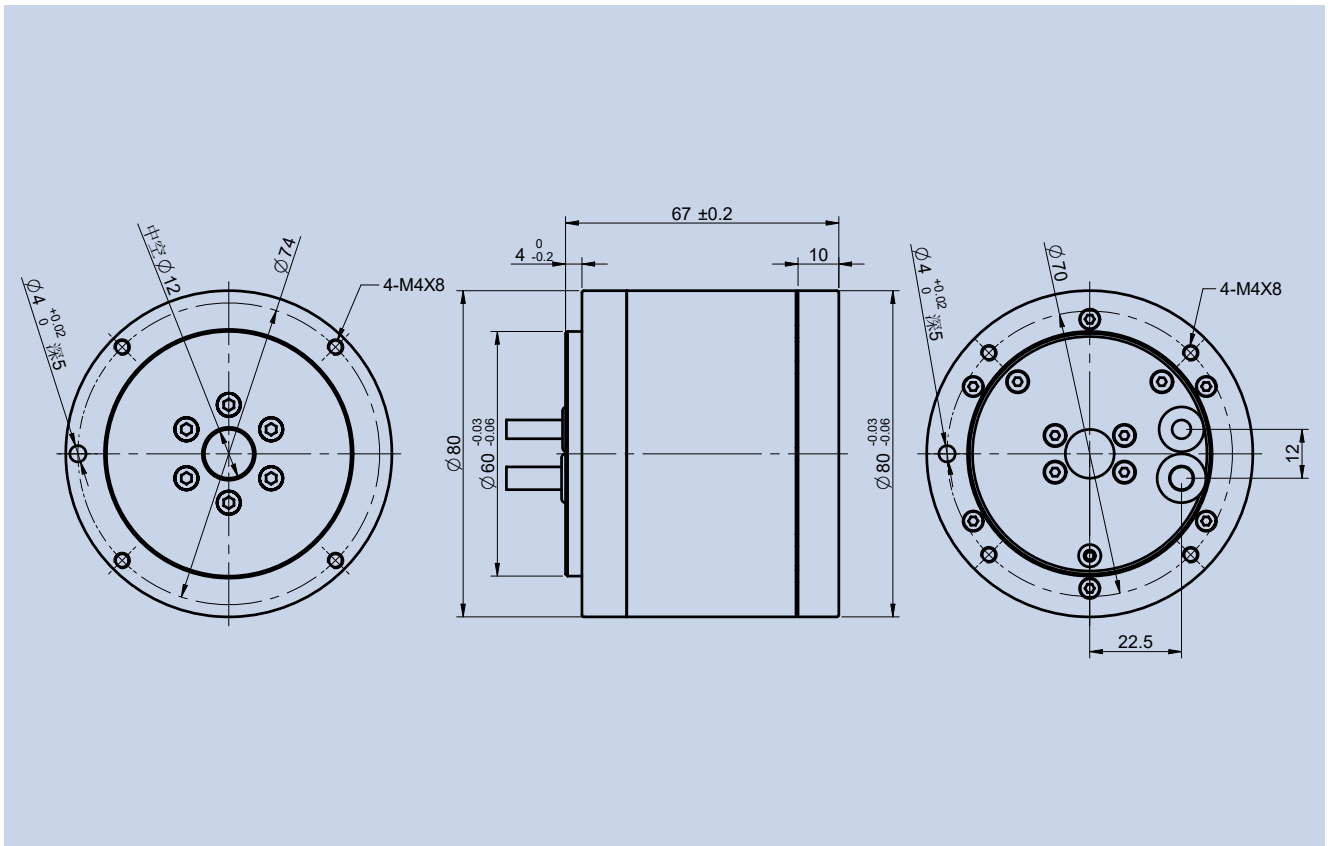

DDN-080067-D-FA-V2

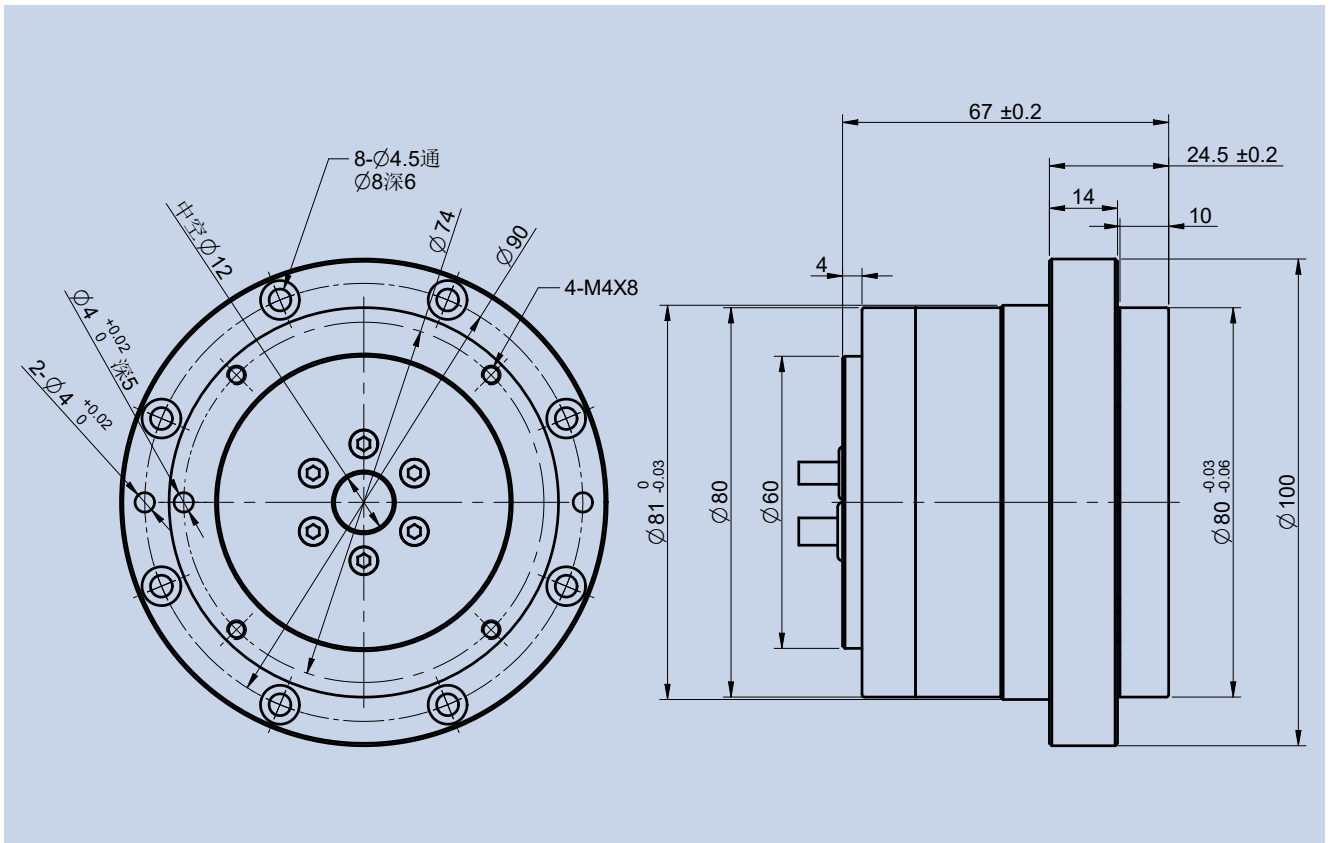

DDN 内转子直驱力矩电机

机械尺寸

DDN-100035-C-FA

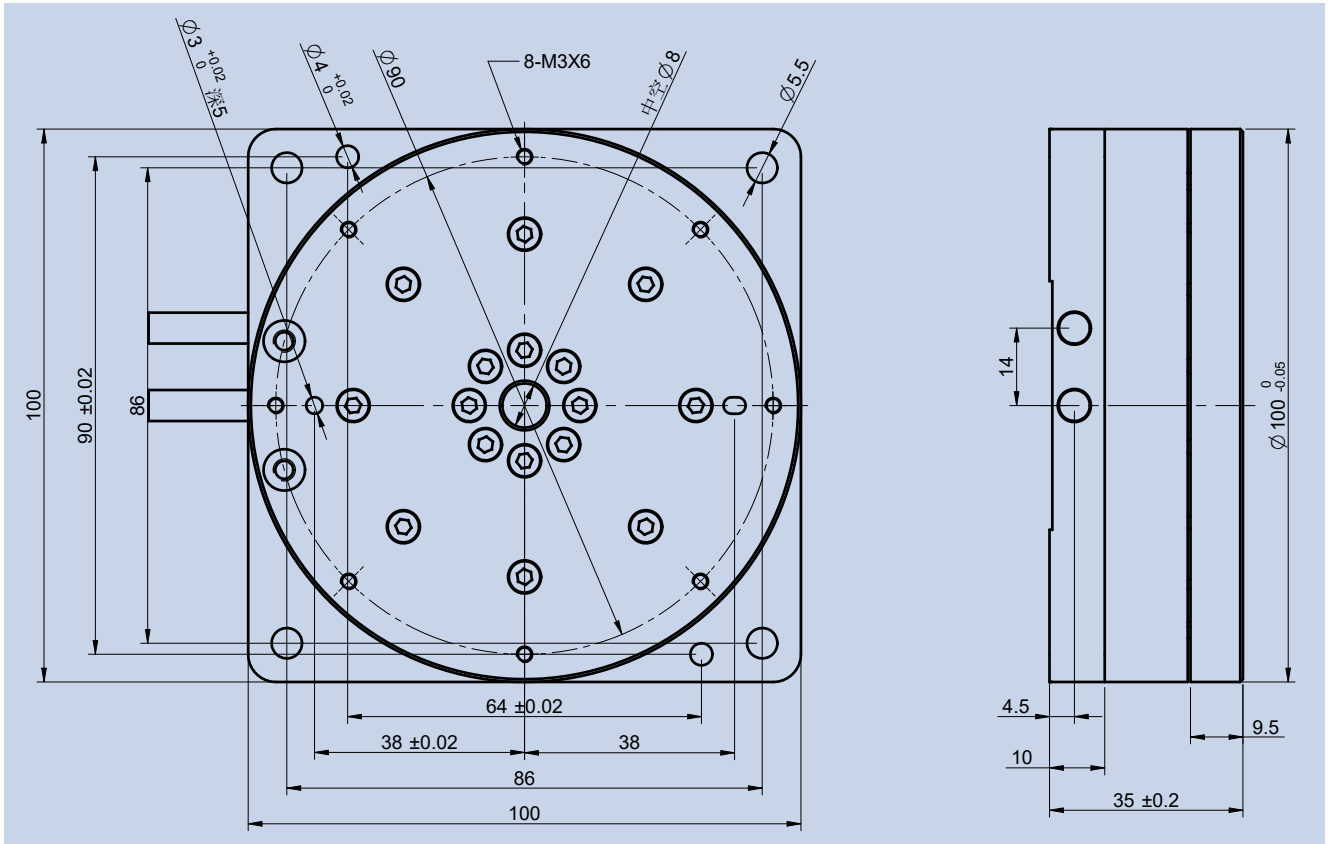

DDN-120035-C-FA

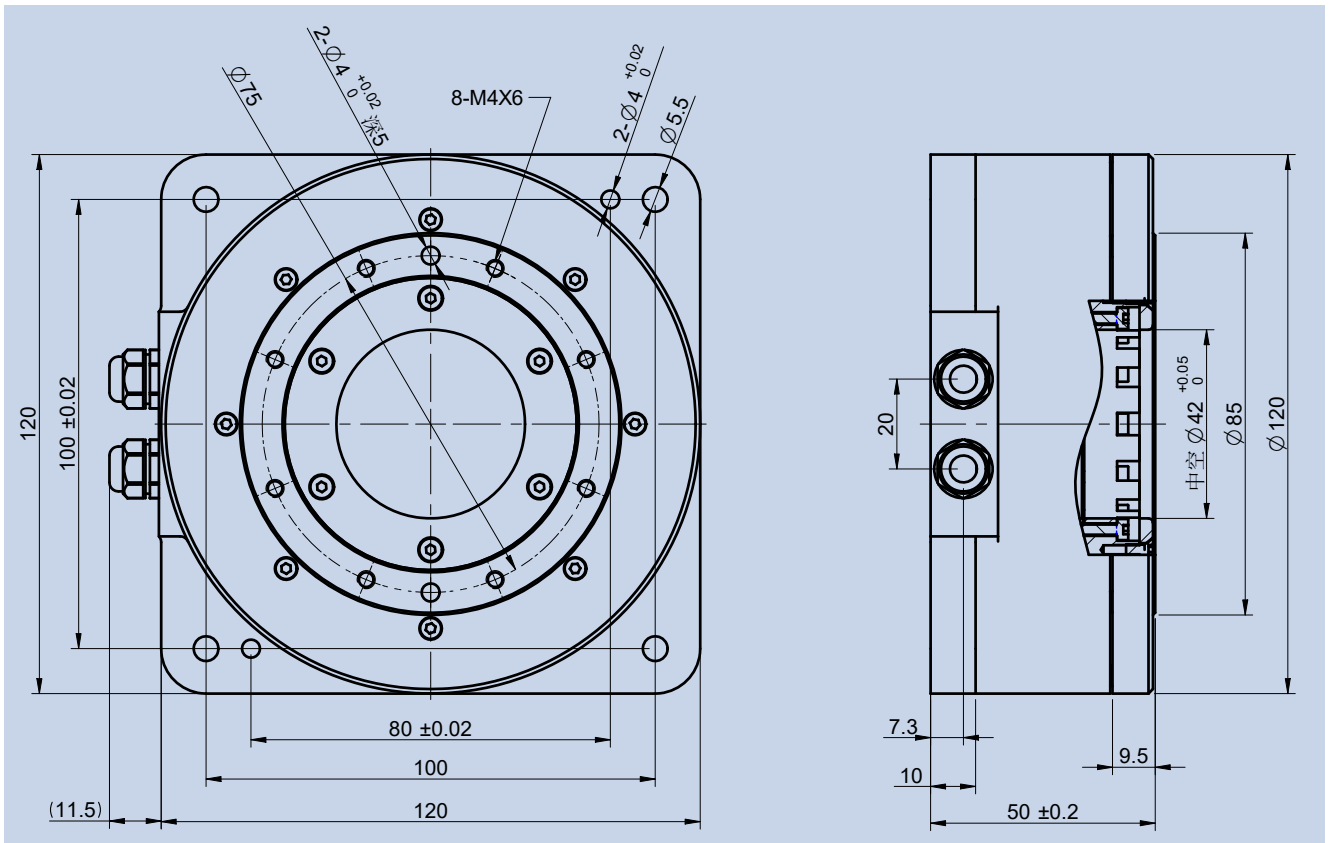

DDN 内转子直驱力矩电机

机械尺寸

DDN-140129-D-FA

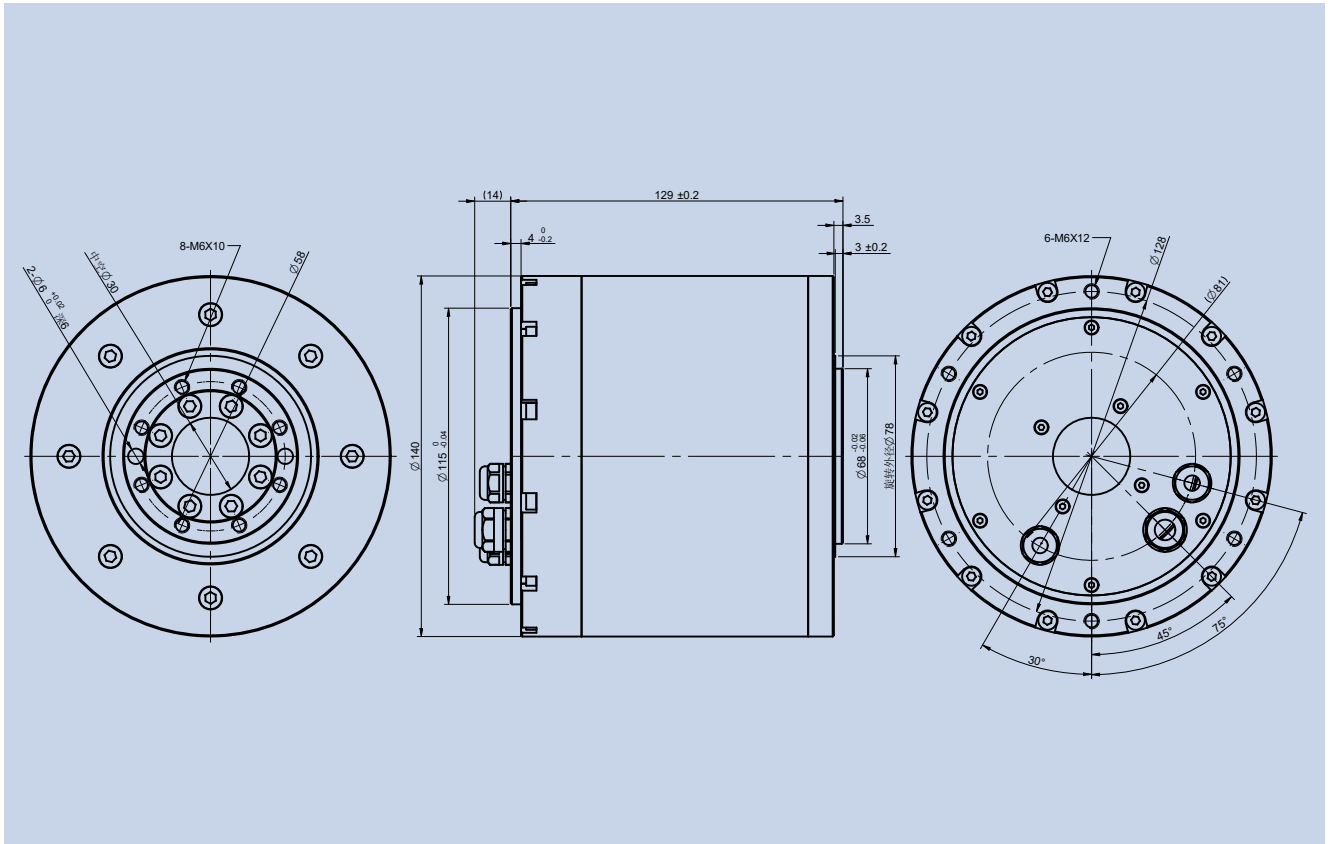

DDN-140189-D-FA

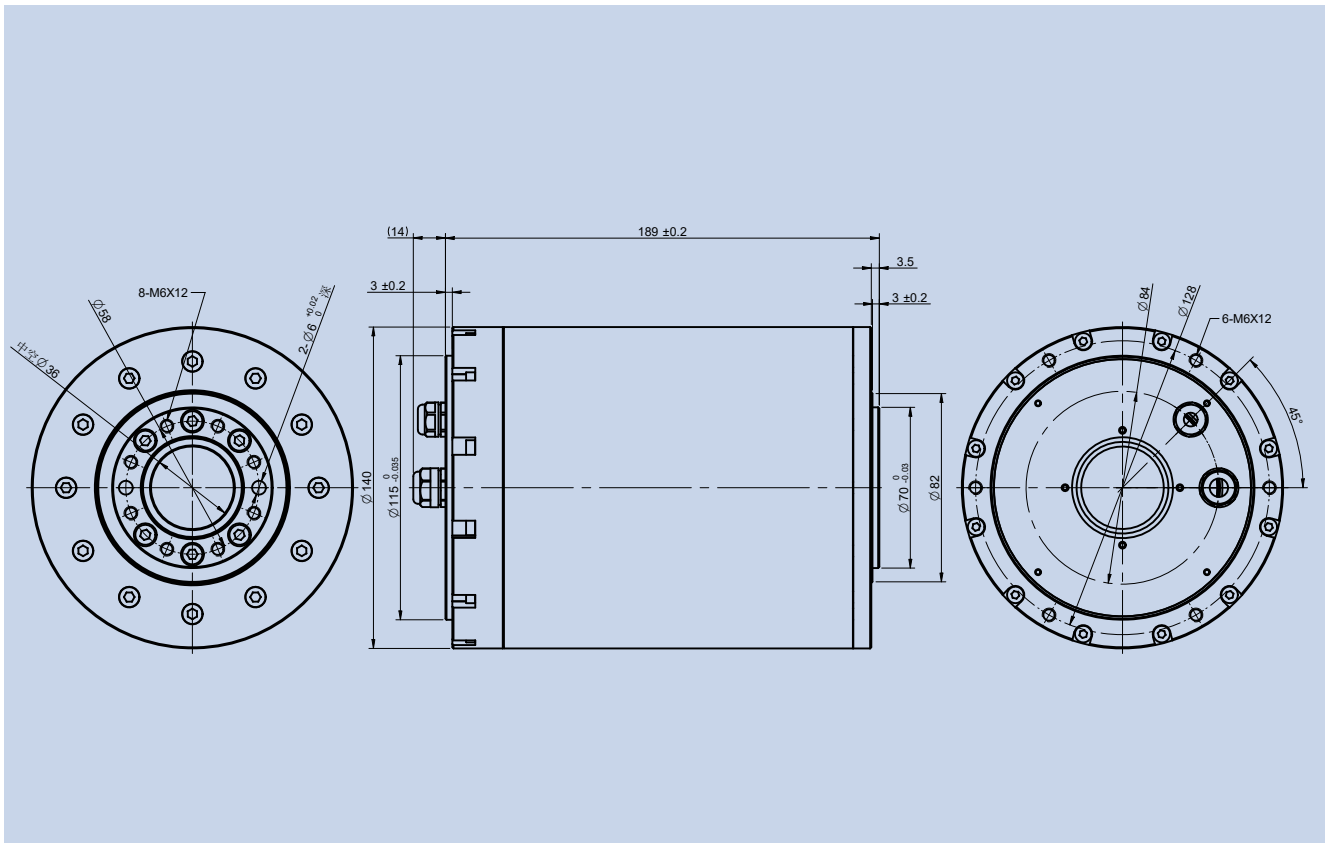

DDN 内转子直驱力矩电机

机械尺寸

DDN-170075-C-FA

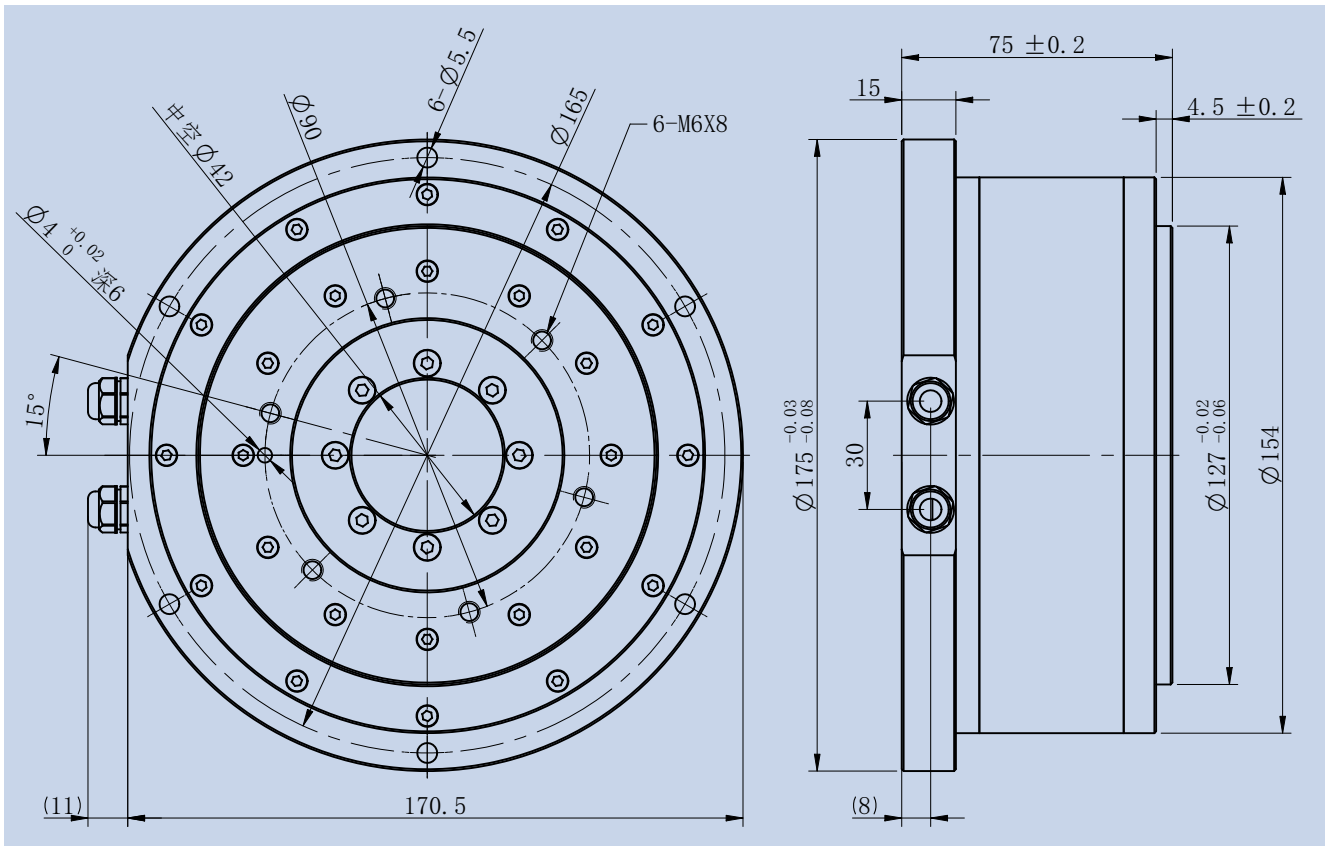

DDN-170080-C-FES

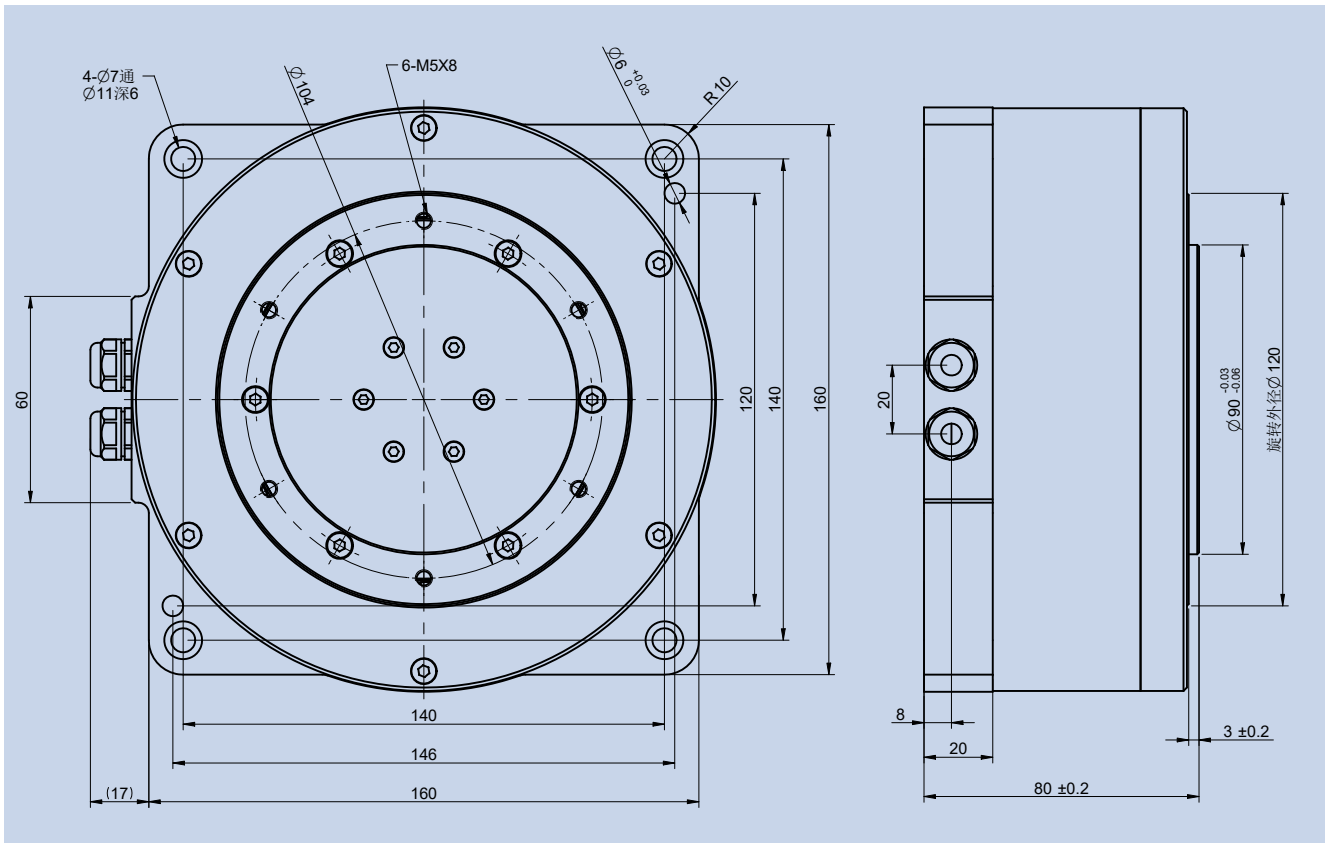

DDN 内转子直驱力矩电机

机械尺寸

DDN-170080-C-FES-V2

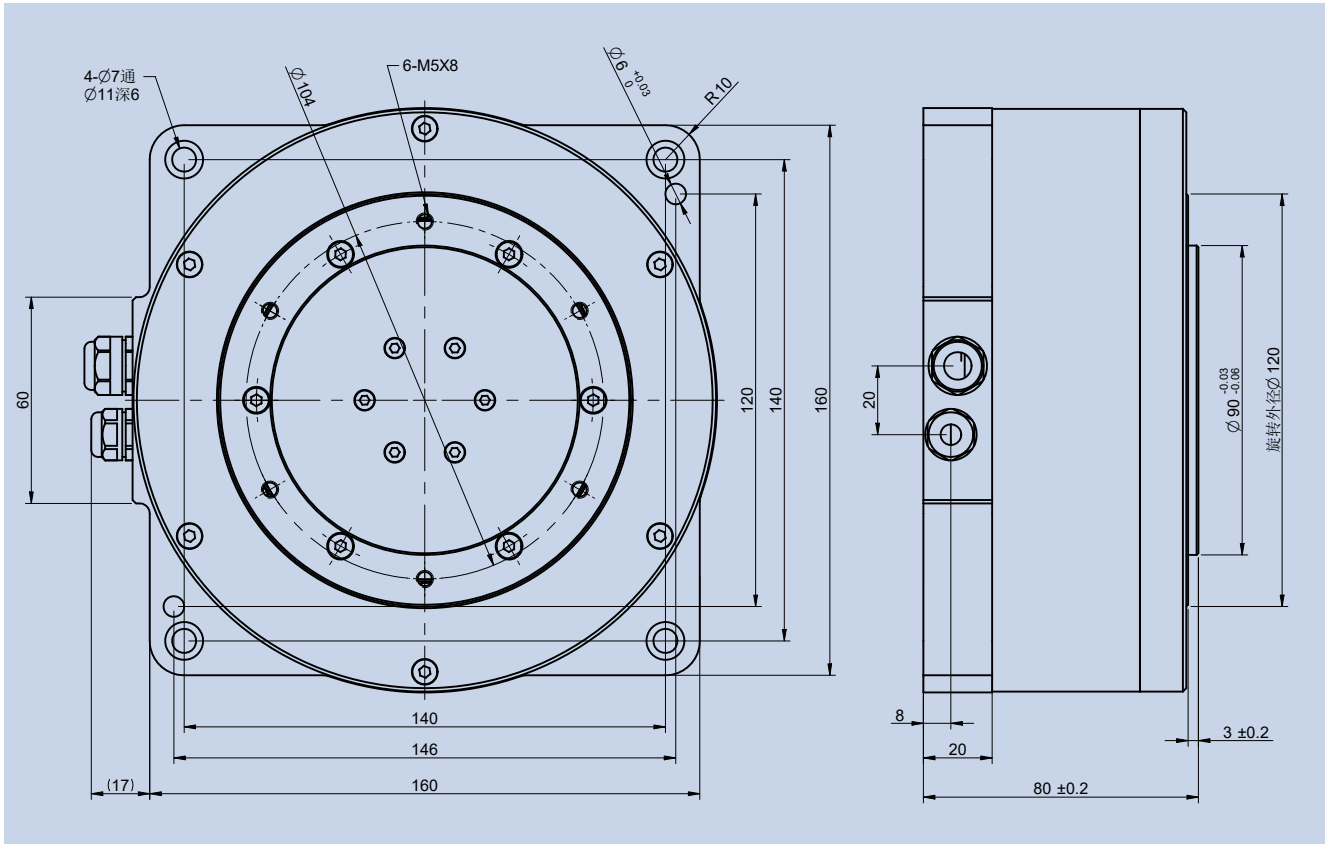

DDN-180055-C-FA

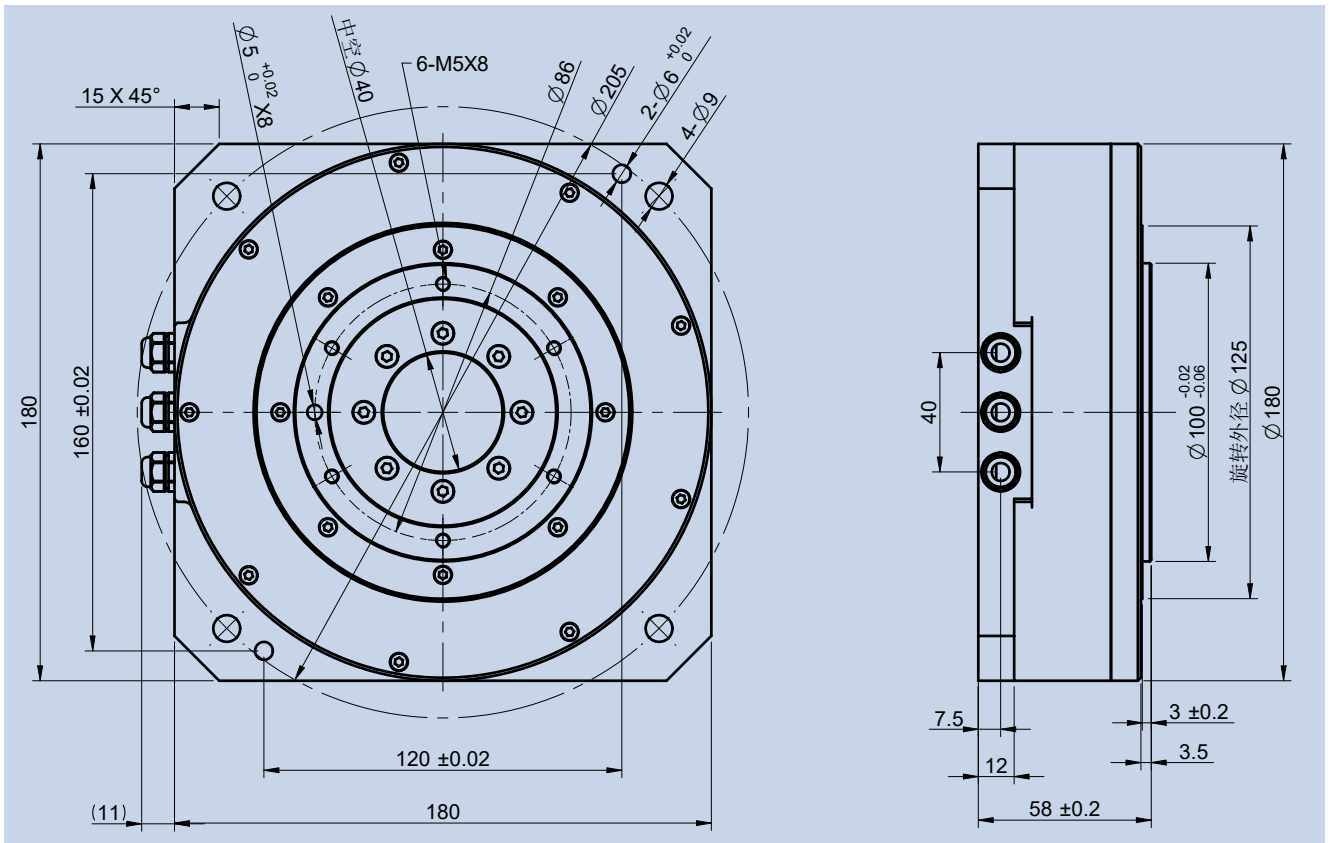

DDN 内转子直驱力矩电机

机械尺寸

DDN-180095-C-FA

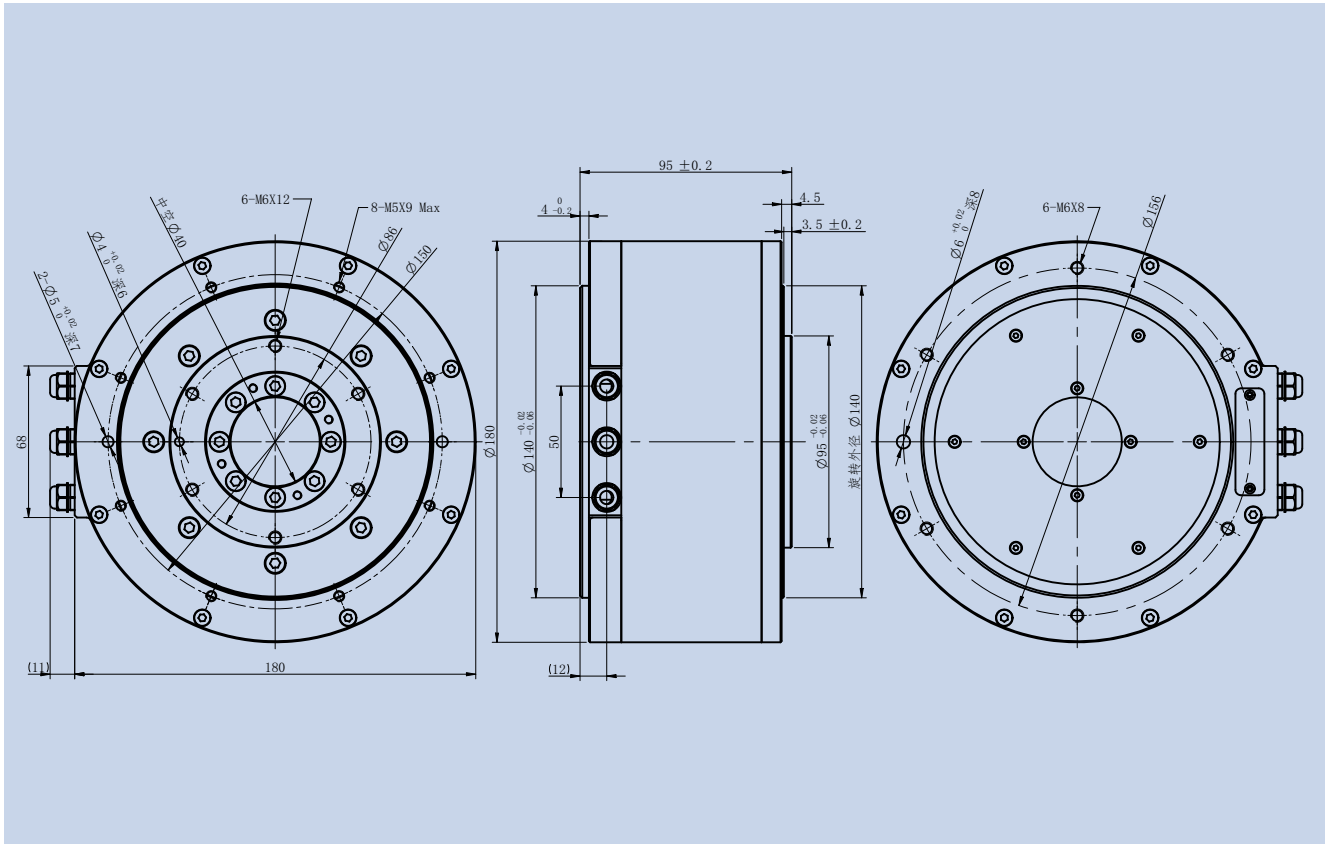

DDN-180098-D-FA

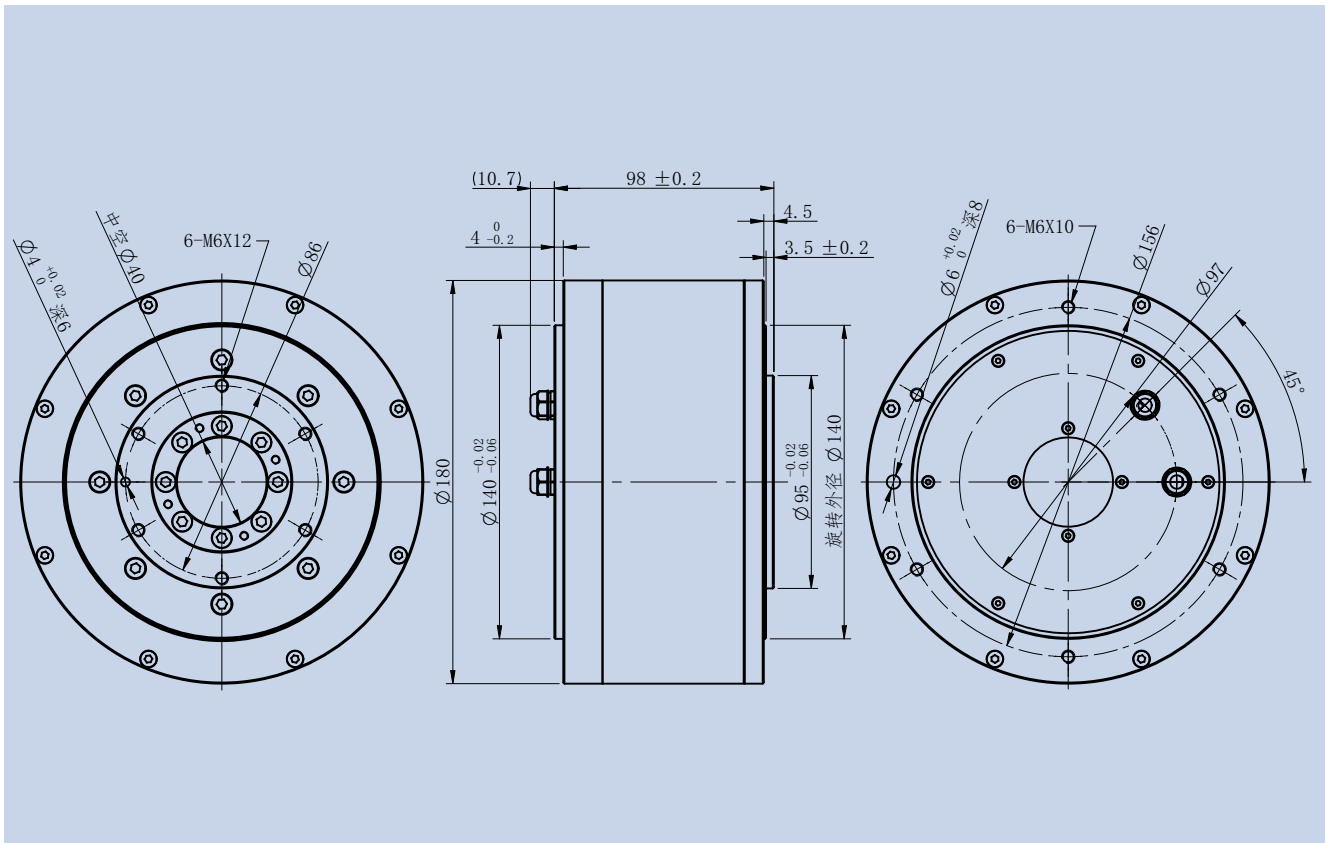

DDN 内转子直驱力矩电机

机械尺寸

DDN-180125-C-FA

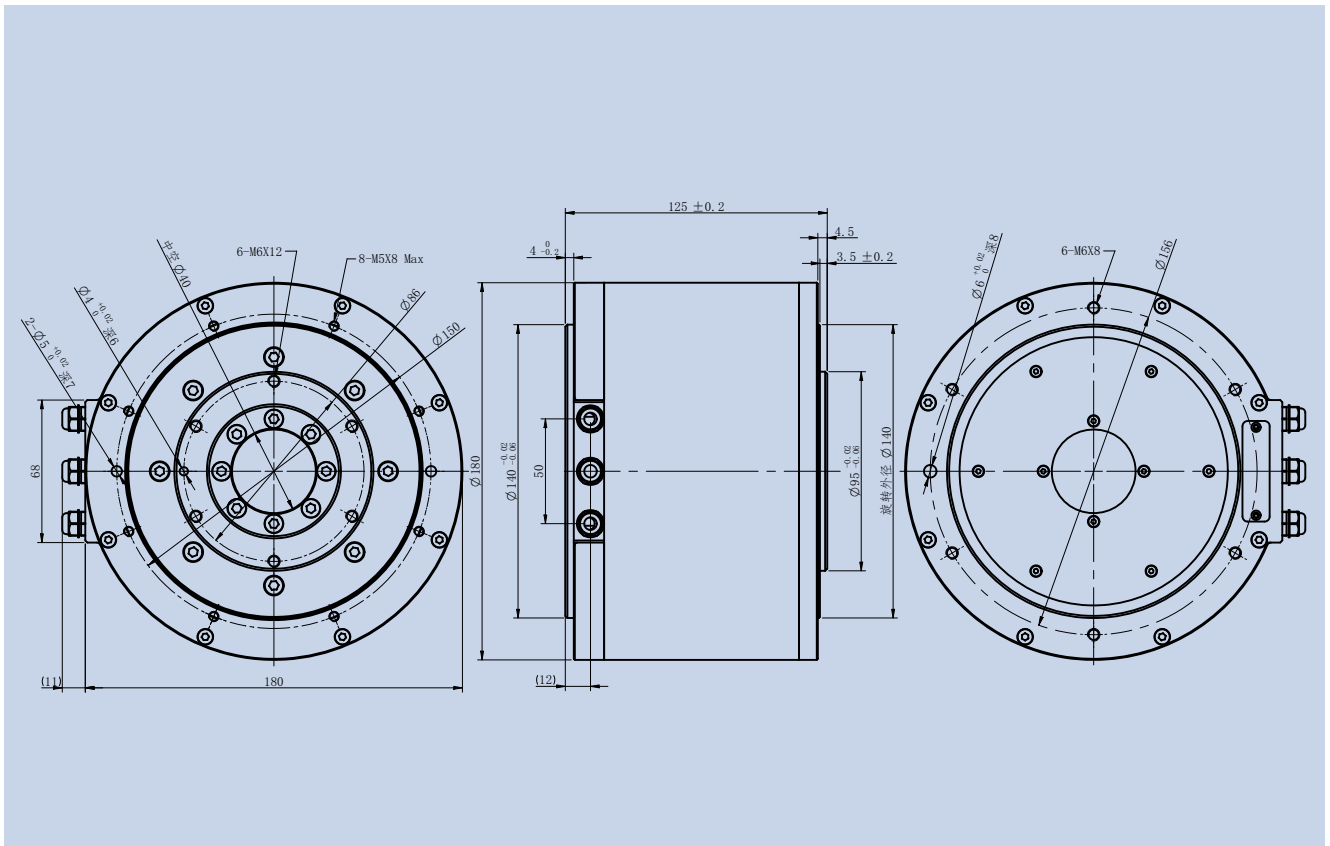

DDN-220070-C-FA

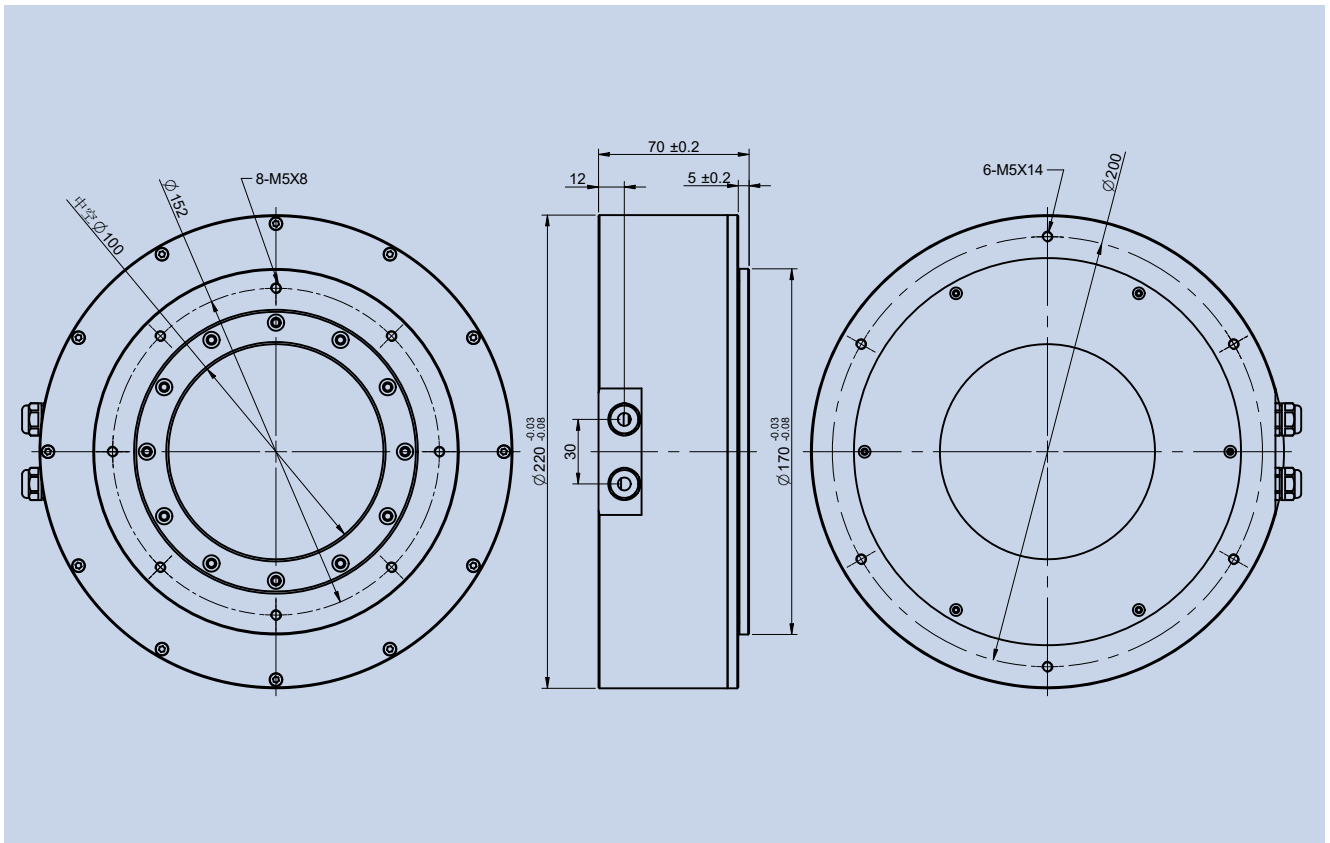

DDW 外转子直驱力矩电机

机械尺寸

DDN-220123-C-FA

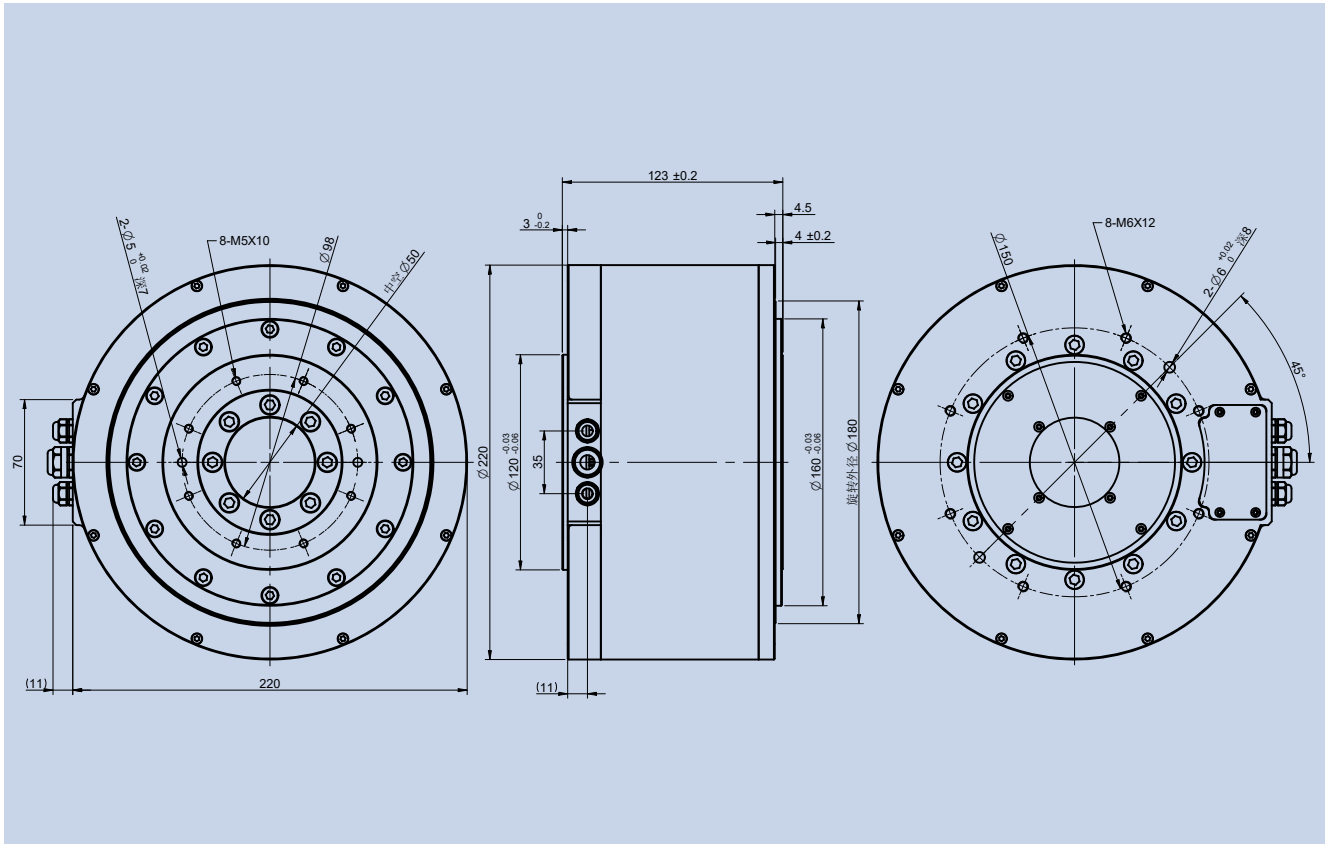

DDN-220168-C-FA

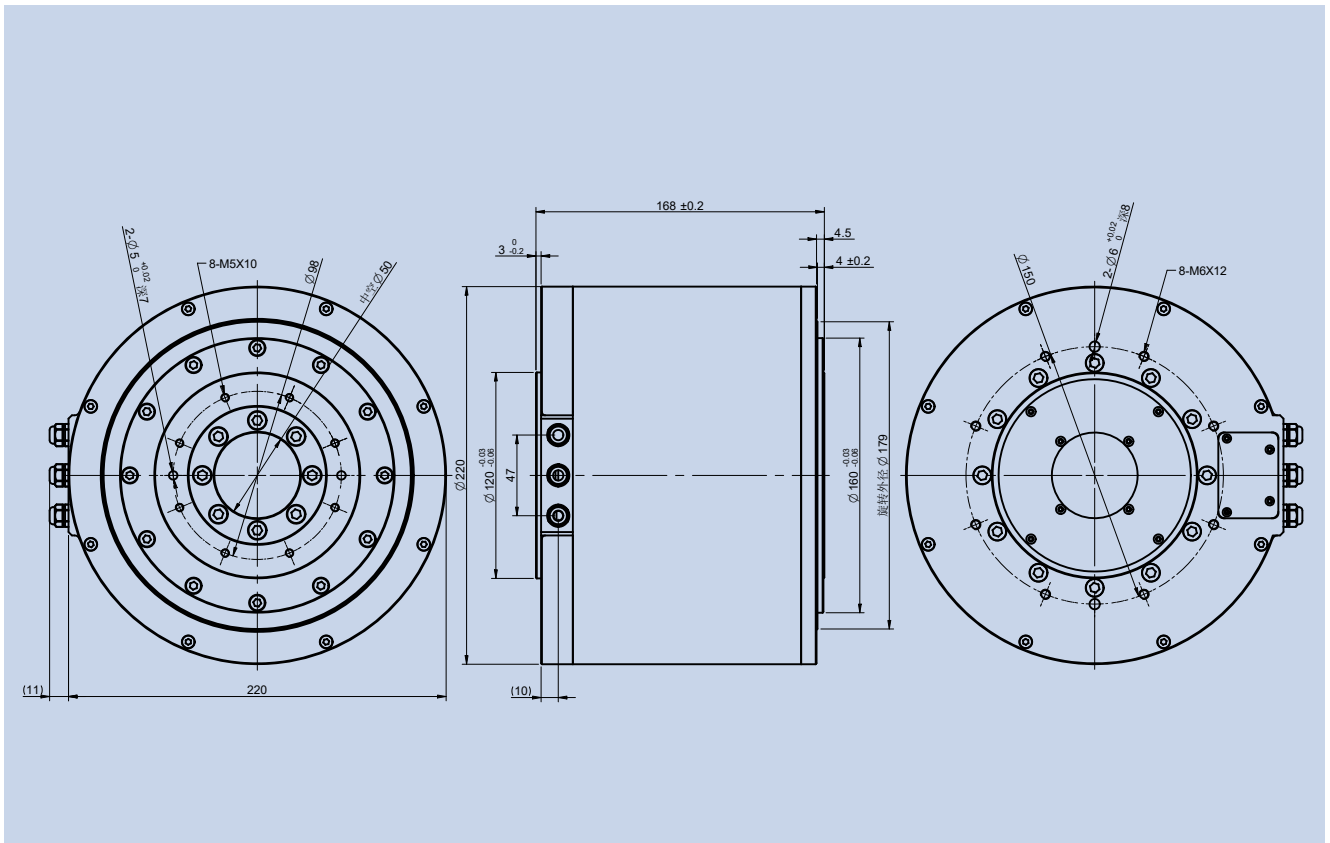

DDW 外转子直驱力矩电机

机械尺寸

DDN-224042-C-FA

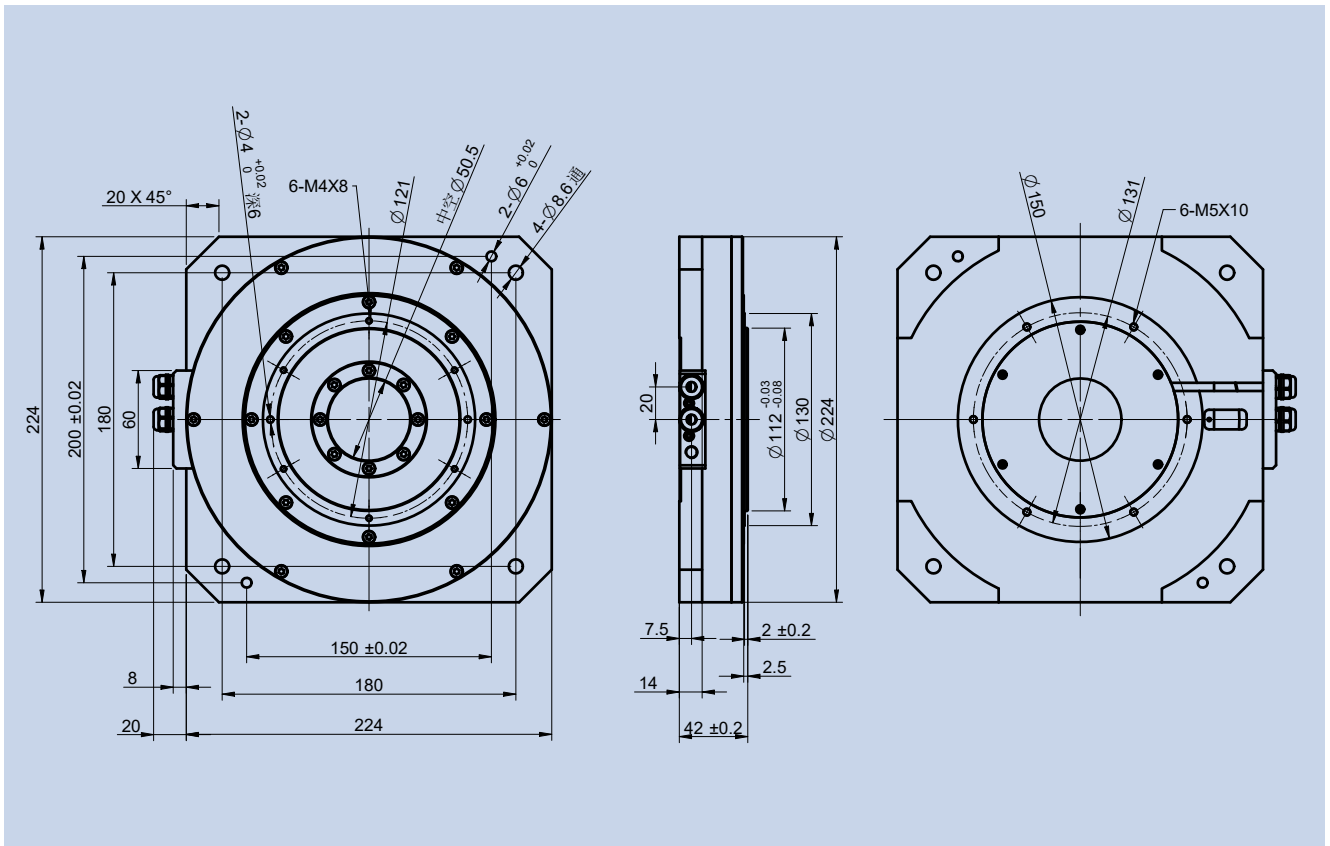

DDN-224042-C-FA-V2

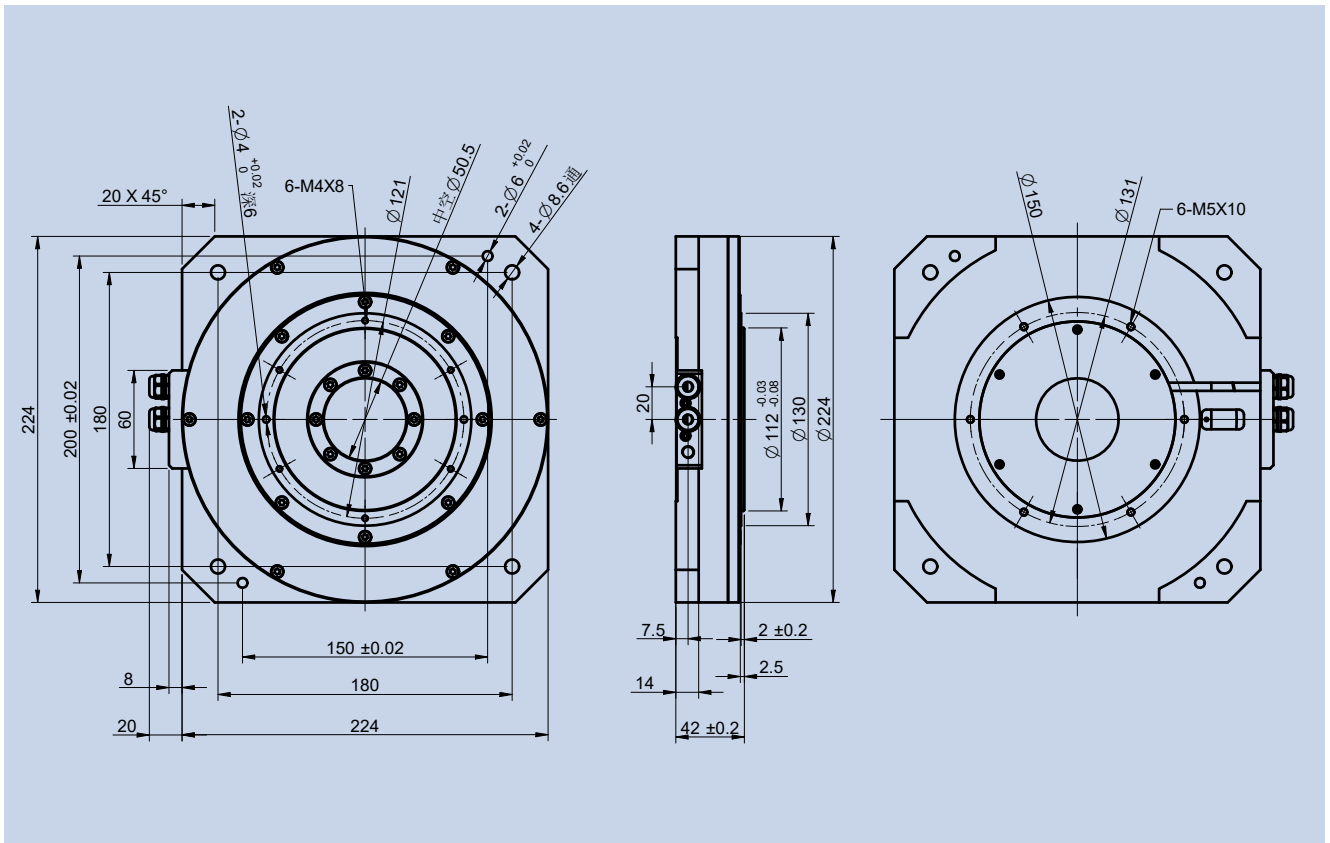

DDW 外转子直驱力矩电机

机械尺寸

DDN-224065-C-FA

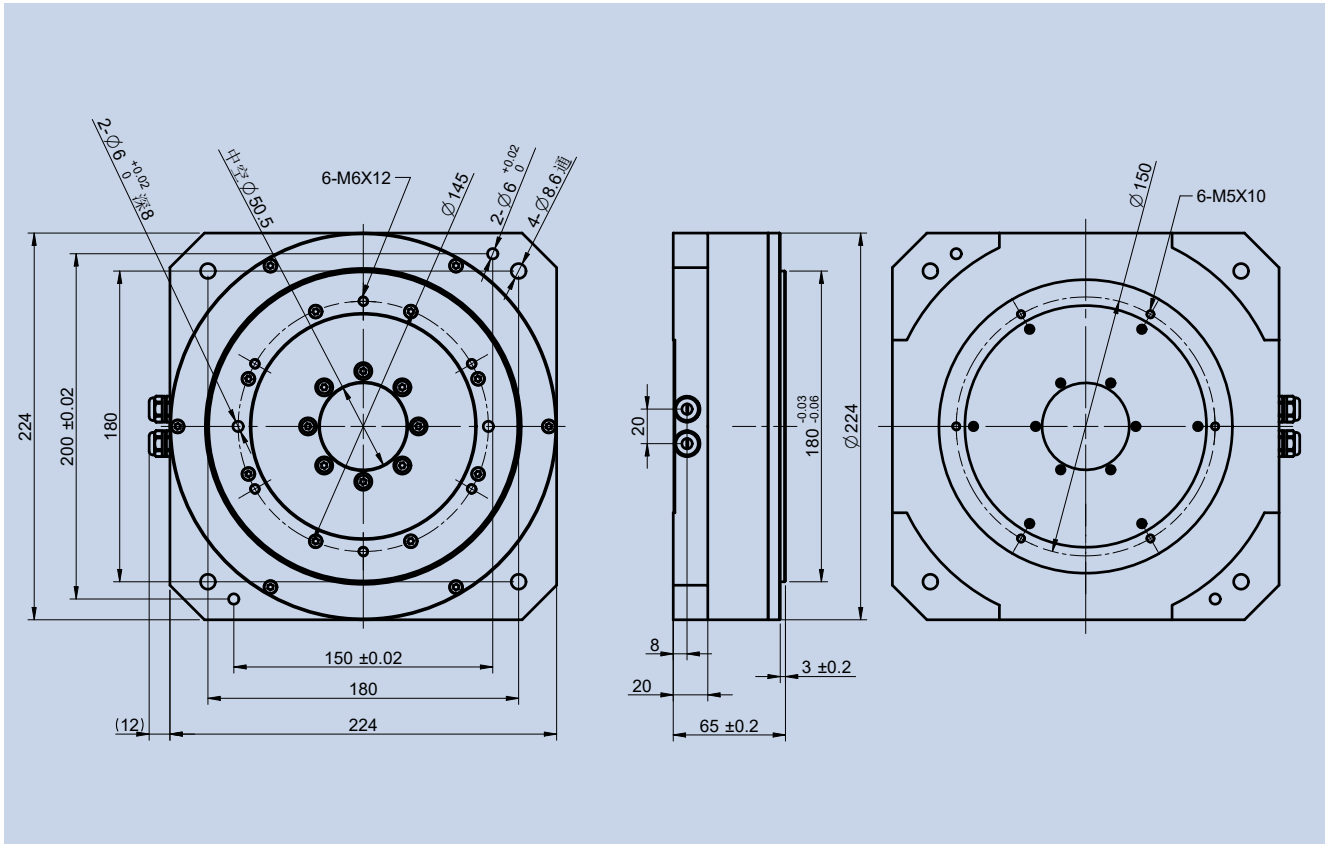

DDN-260208-D-FA2-W

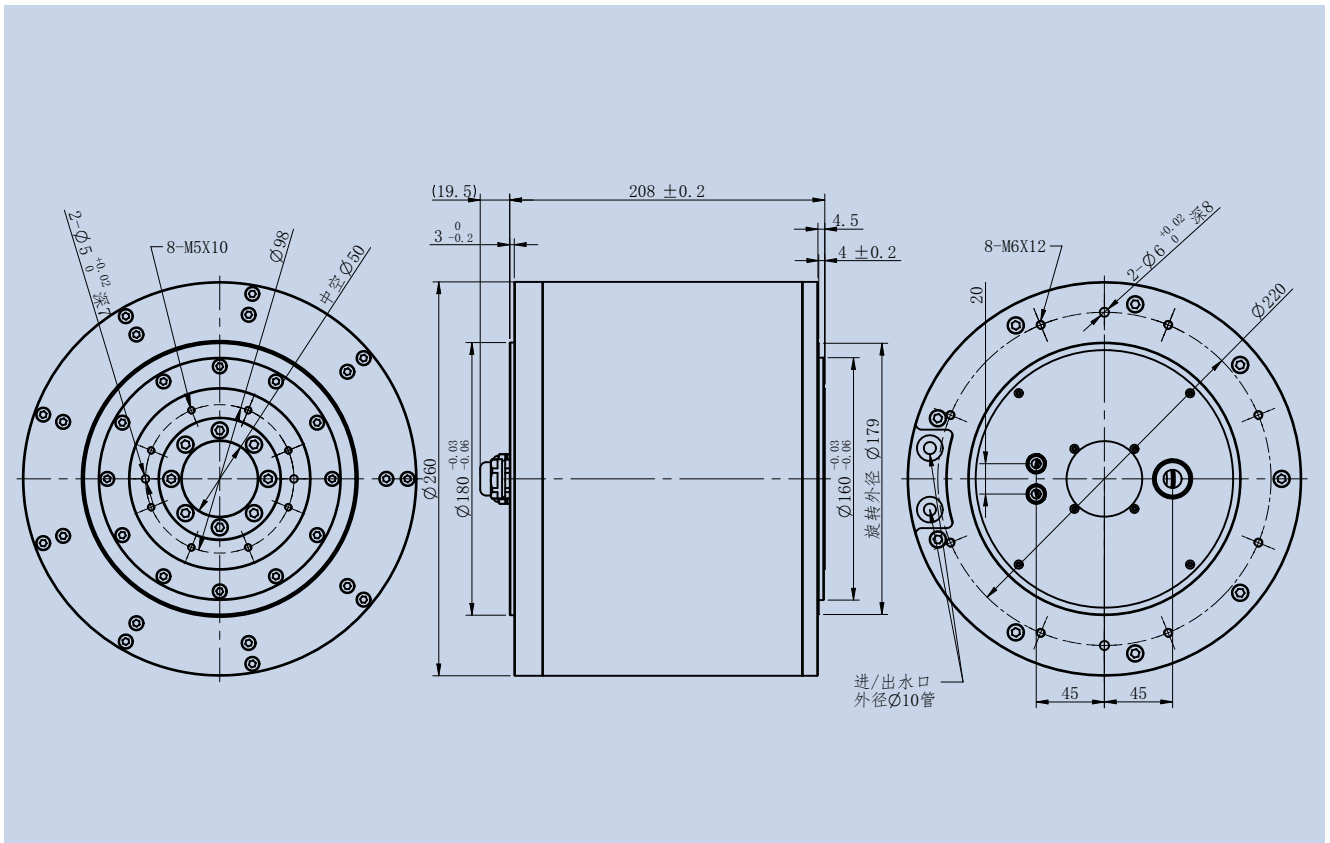

DDW 外转子直驱力矩电机

机械尺寸

DDN-380230-C-FL2-W

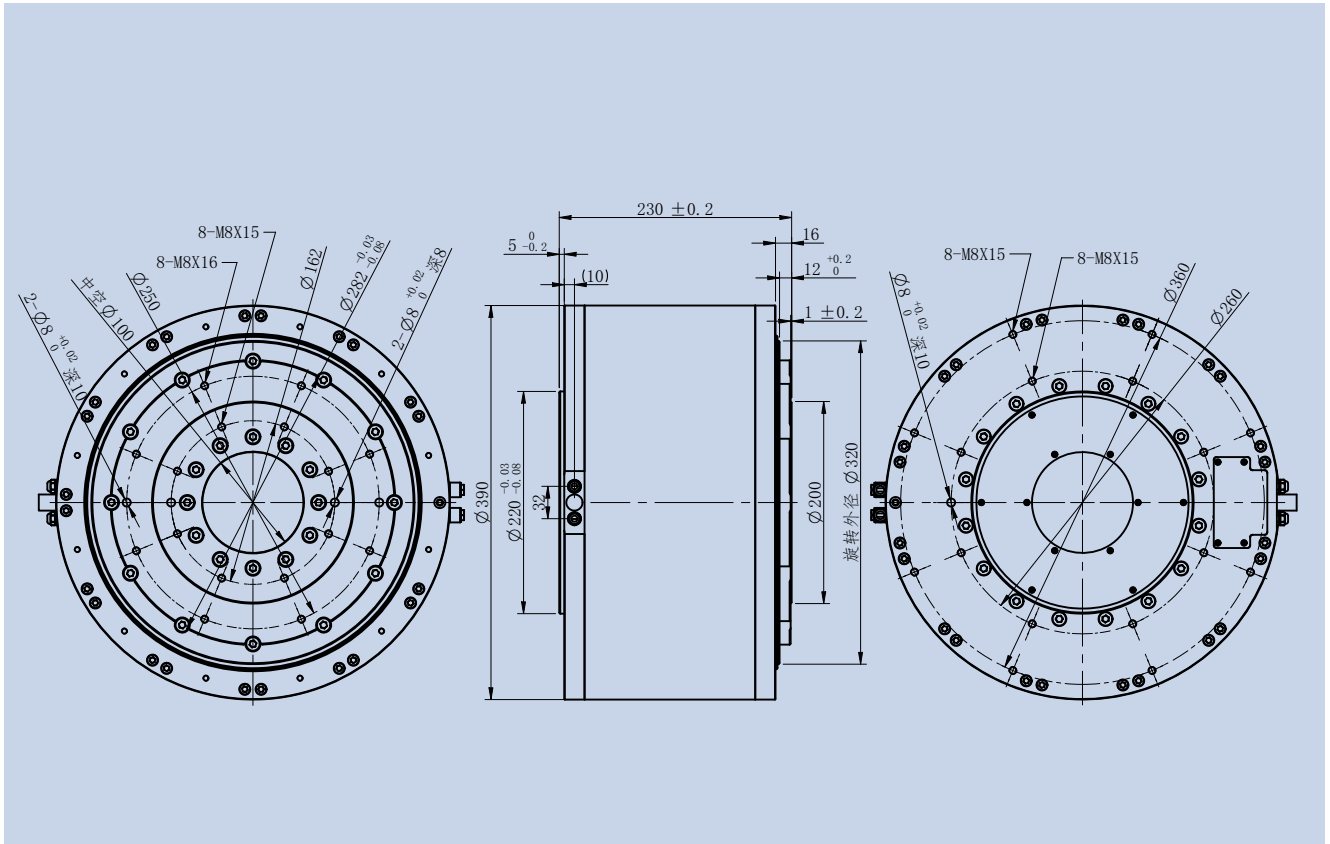

DDN-390245-C-FL

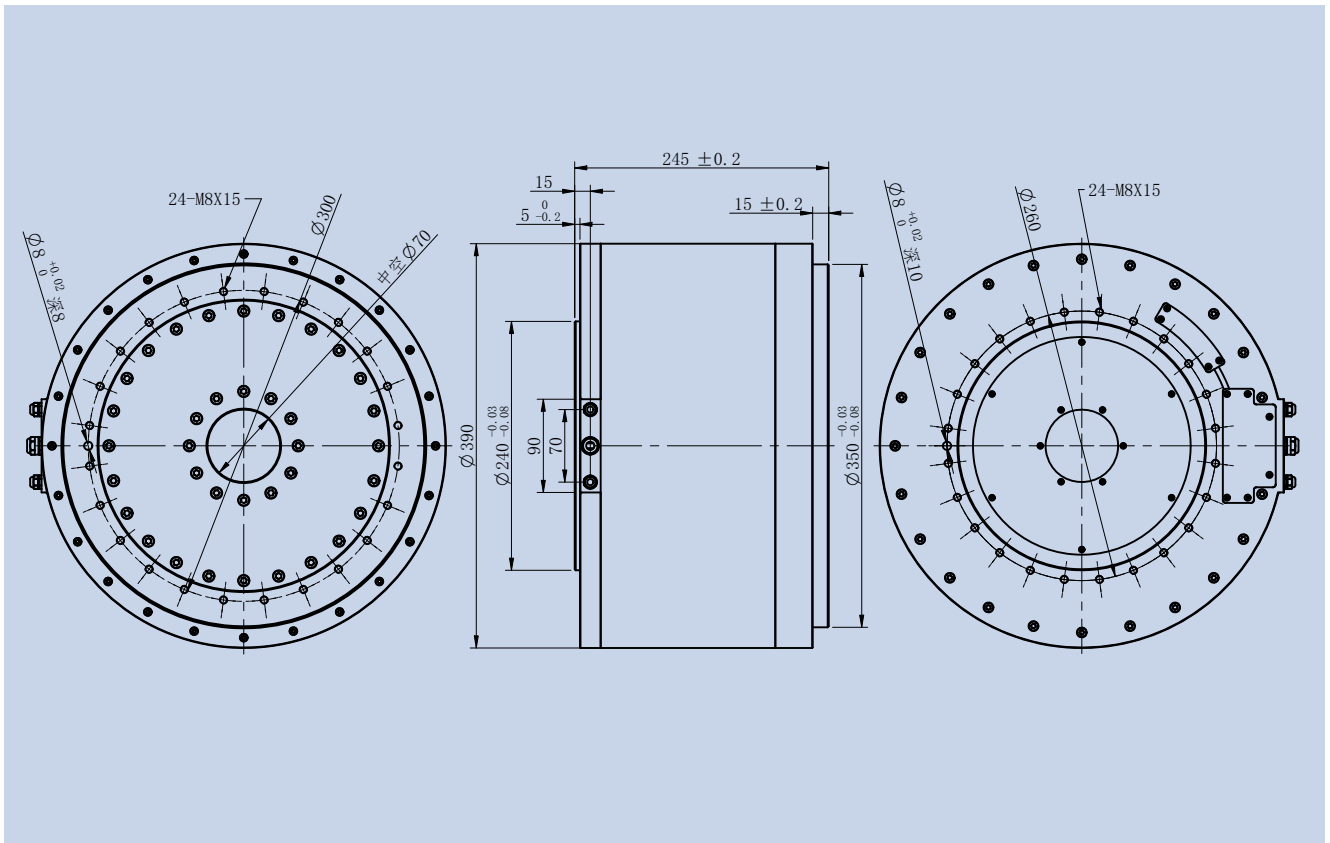

DDW 外转子直驱力矩电机

机械尺寸

DDN-408077-C-FA

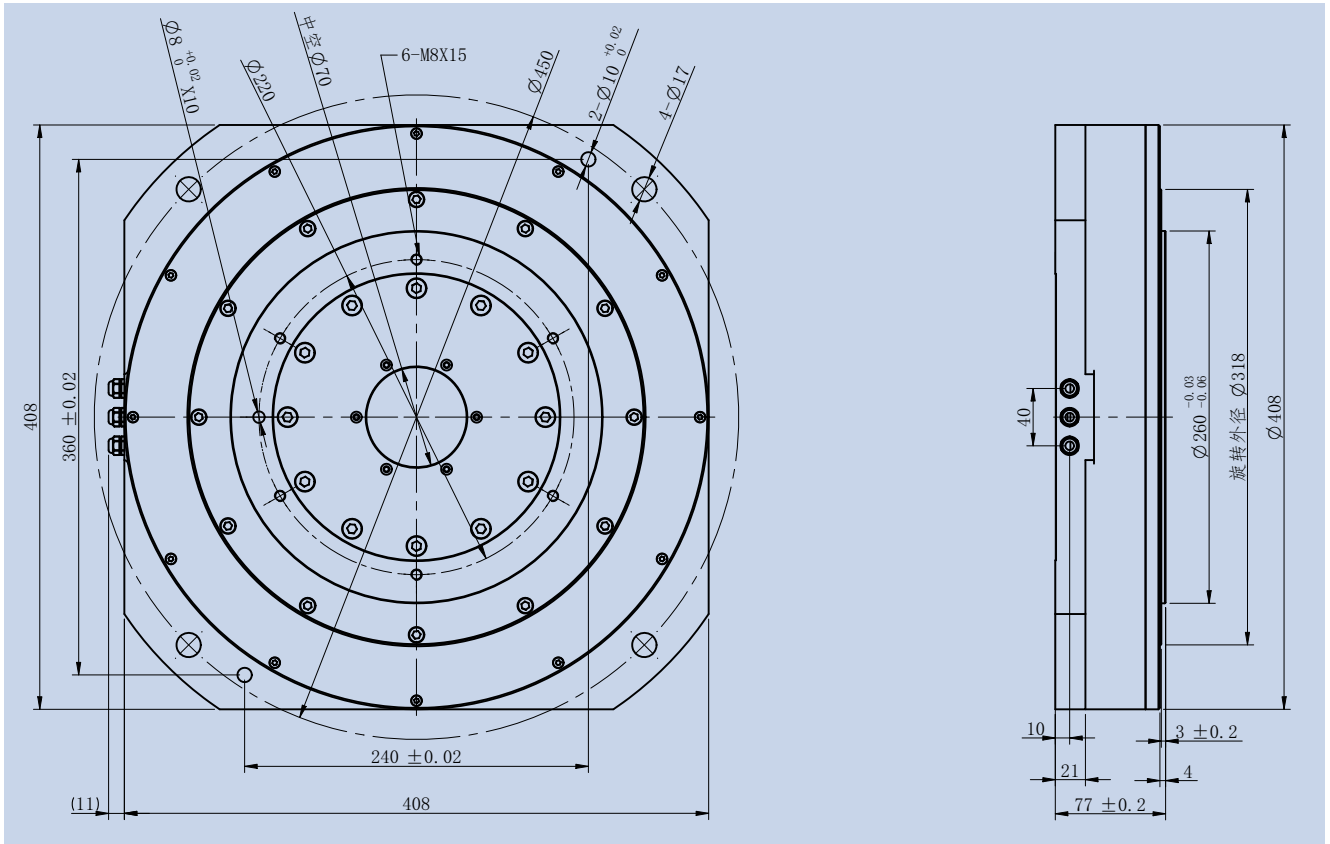

DDN-408077-C-FL

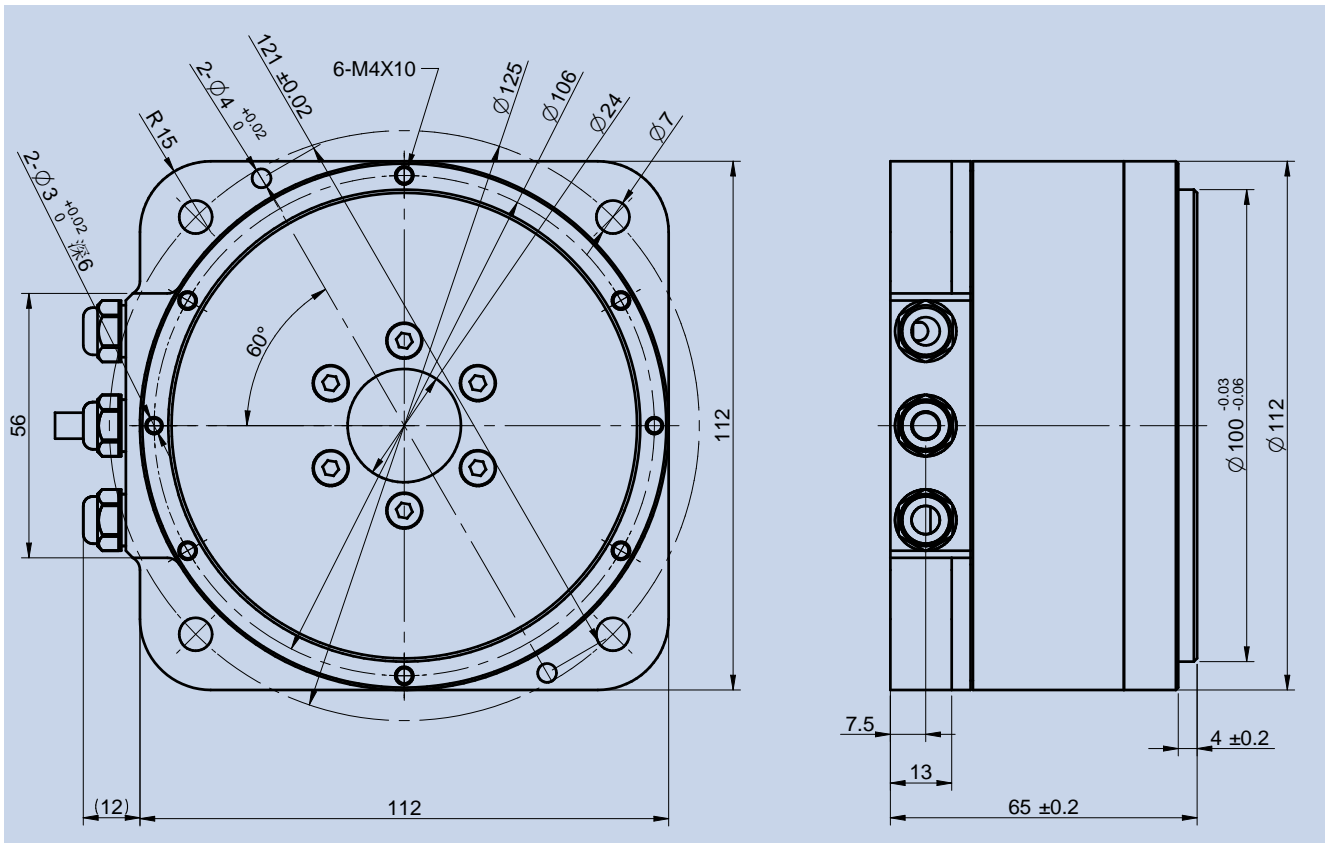

DDW 外转子直驱力矩电机

机械尺寸

DDN-408102-C-FL

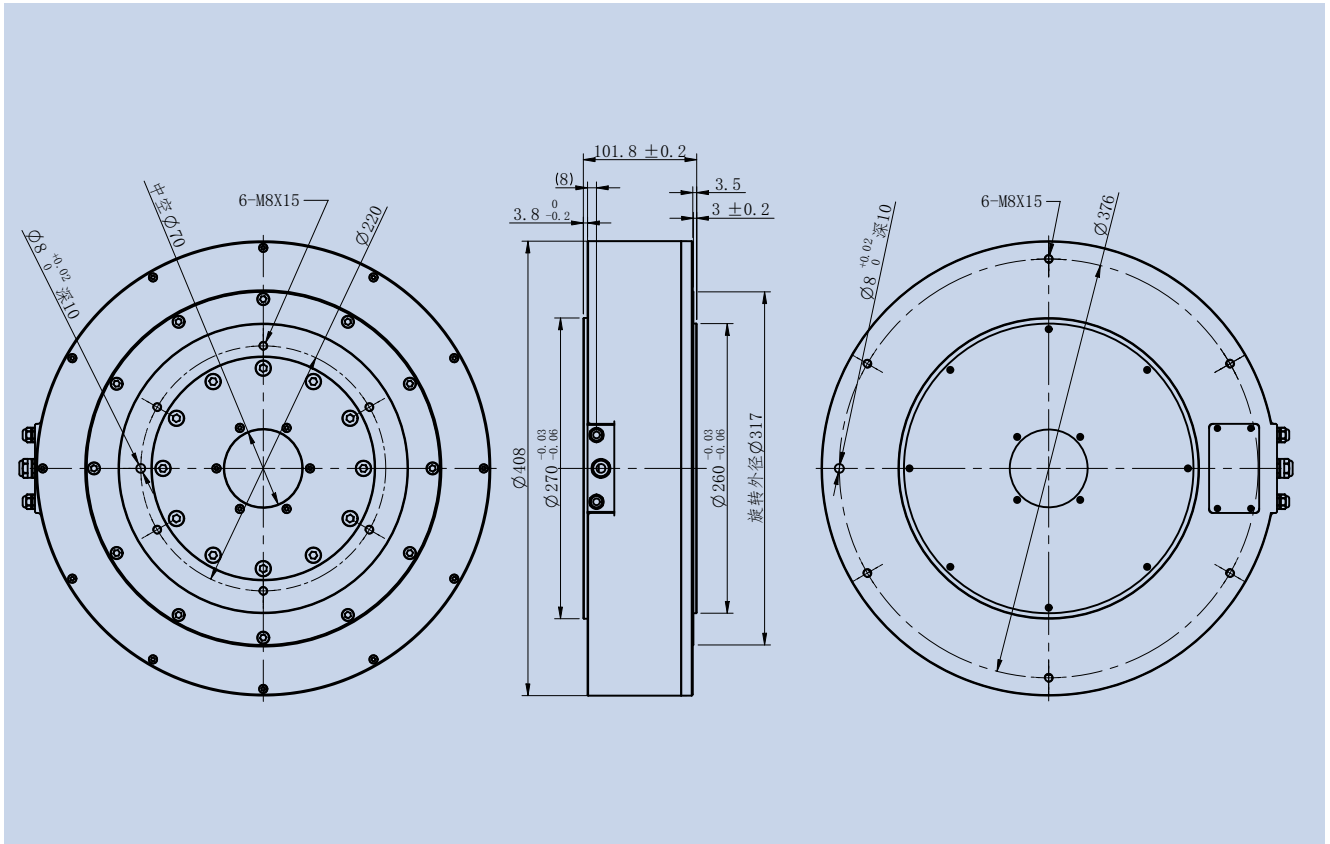

DDN-408102-D-FA

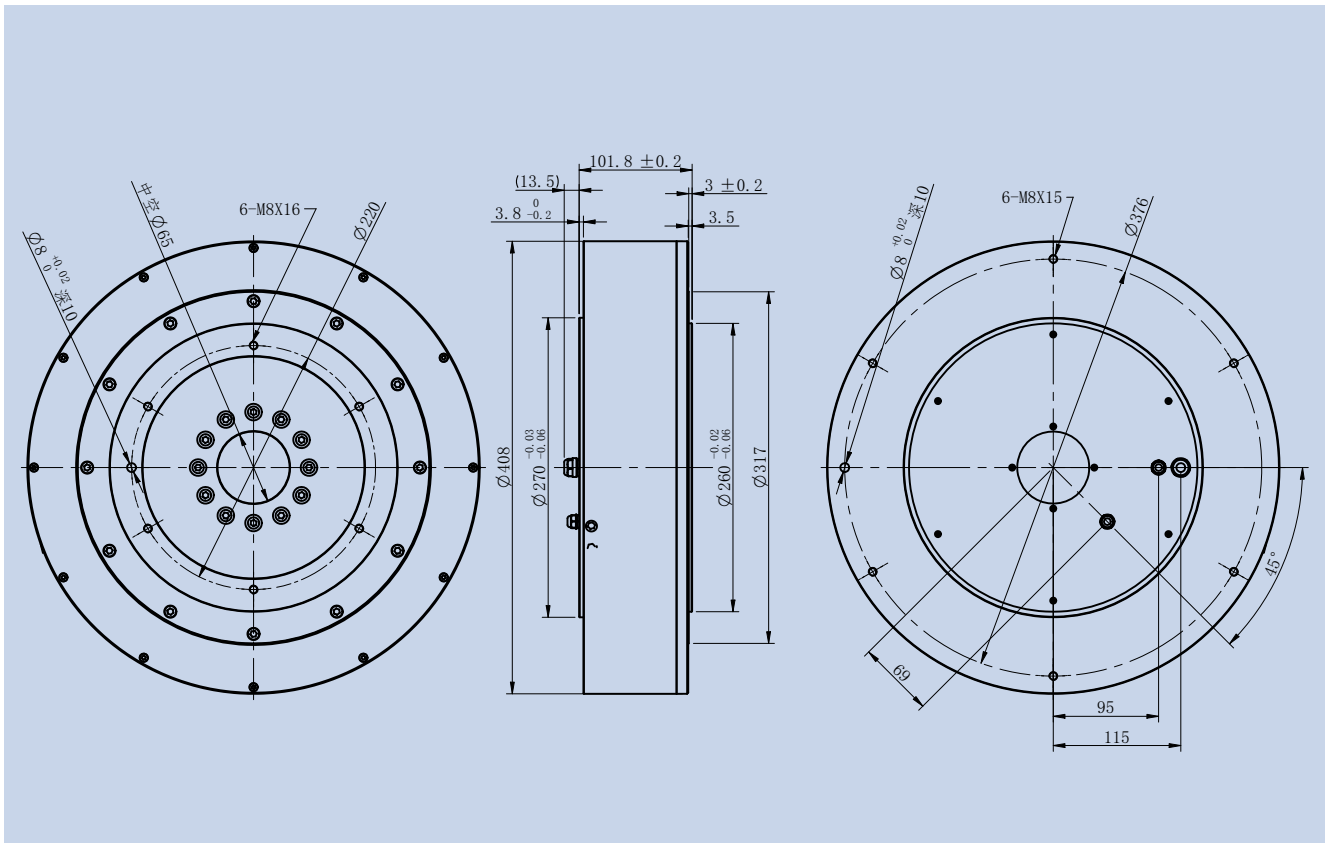

DDW 外转子直驱力矩电机

机械尺寸

DDN-408165-C-FA-V2

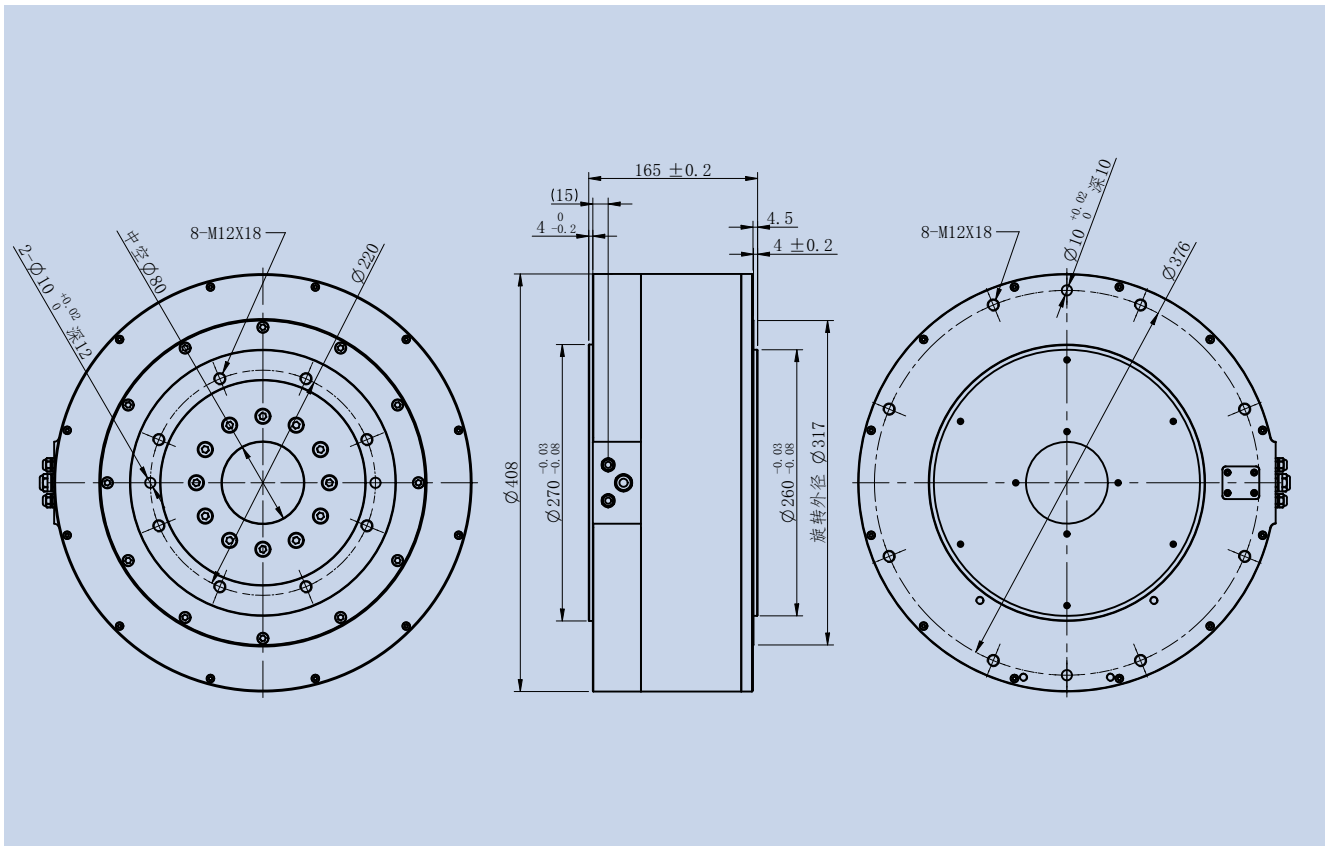

DDN-408165-C-FA-V3

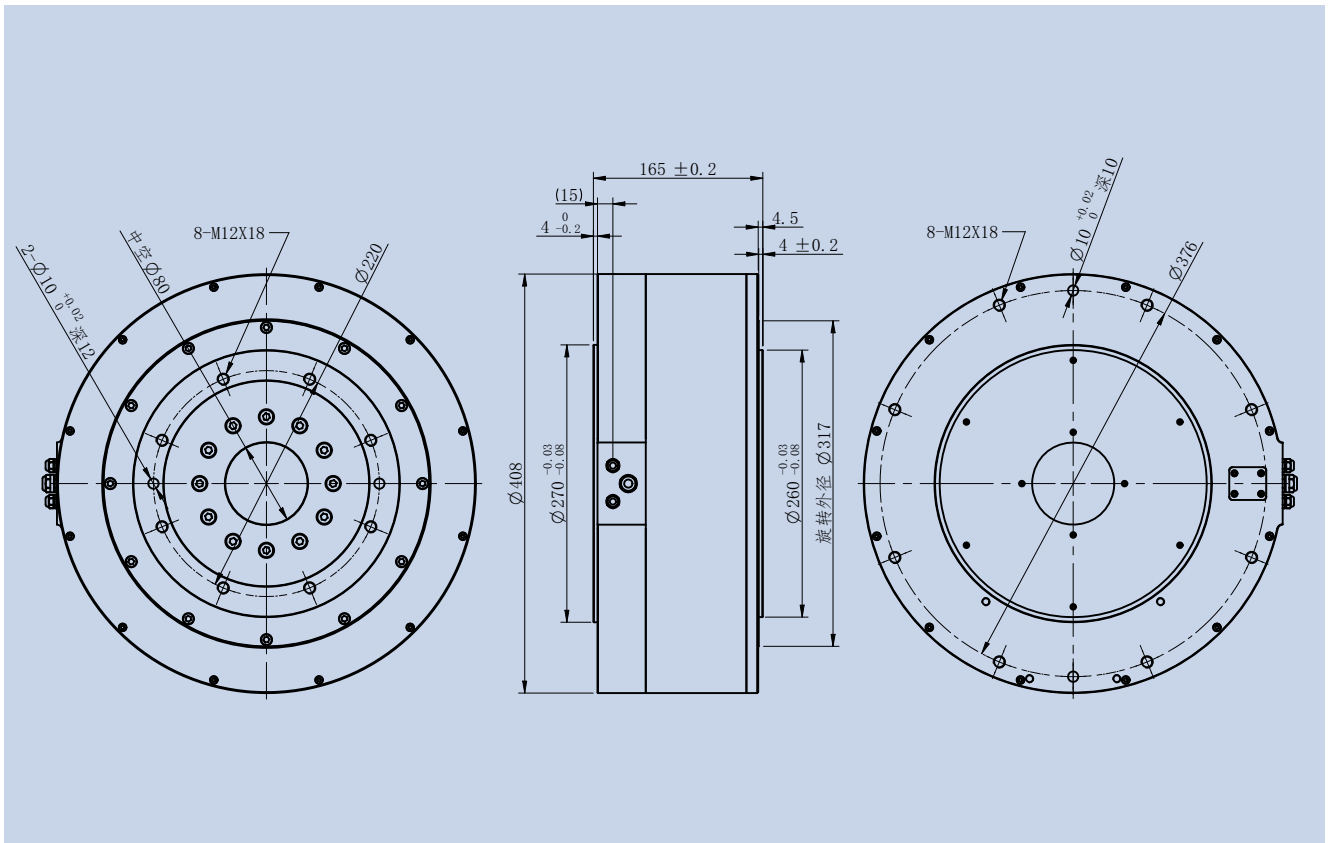

DDW 外转子直驱力矩电机

机械尺寸

DDN-408165-D-FA-V3

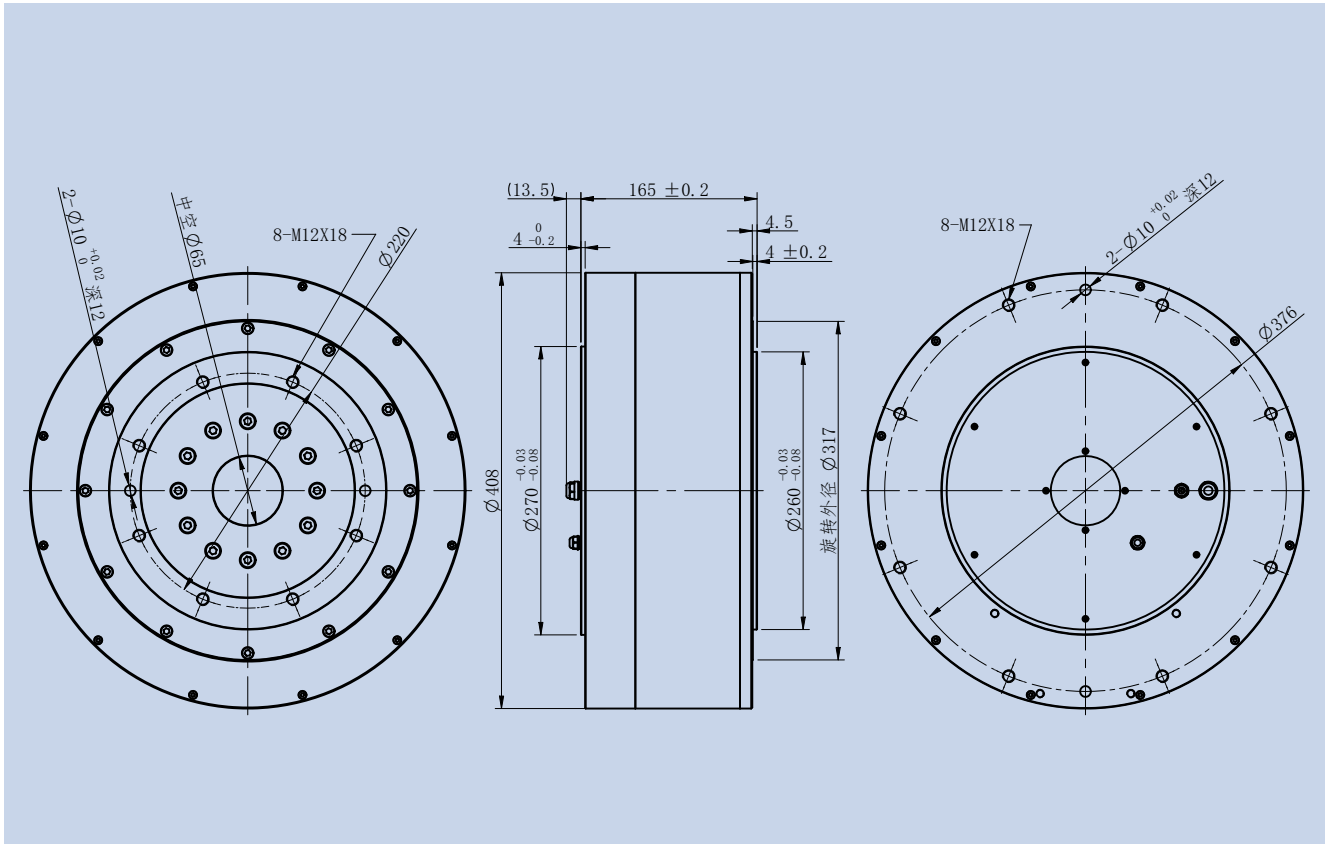

DDN-408180-C-FA-V2

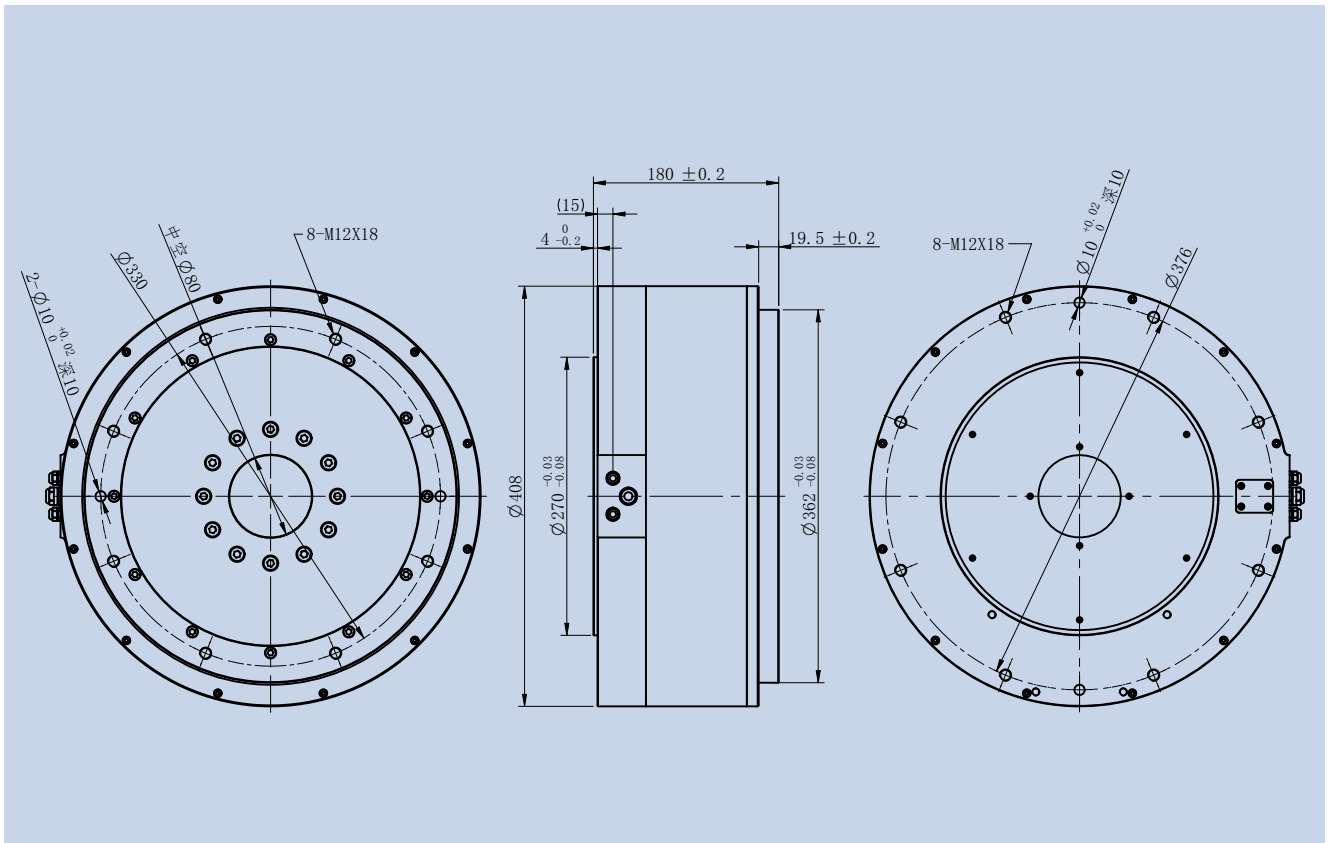

DDW 外转子直驱力矩电机

机械尺寸

DDN-408180-C-FL-V2

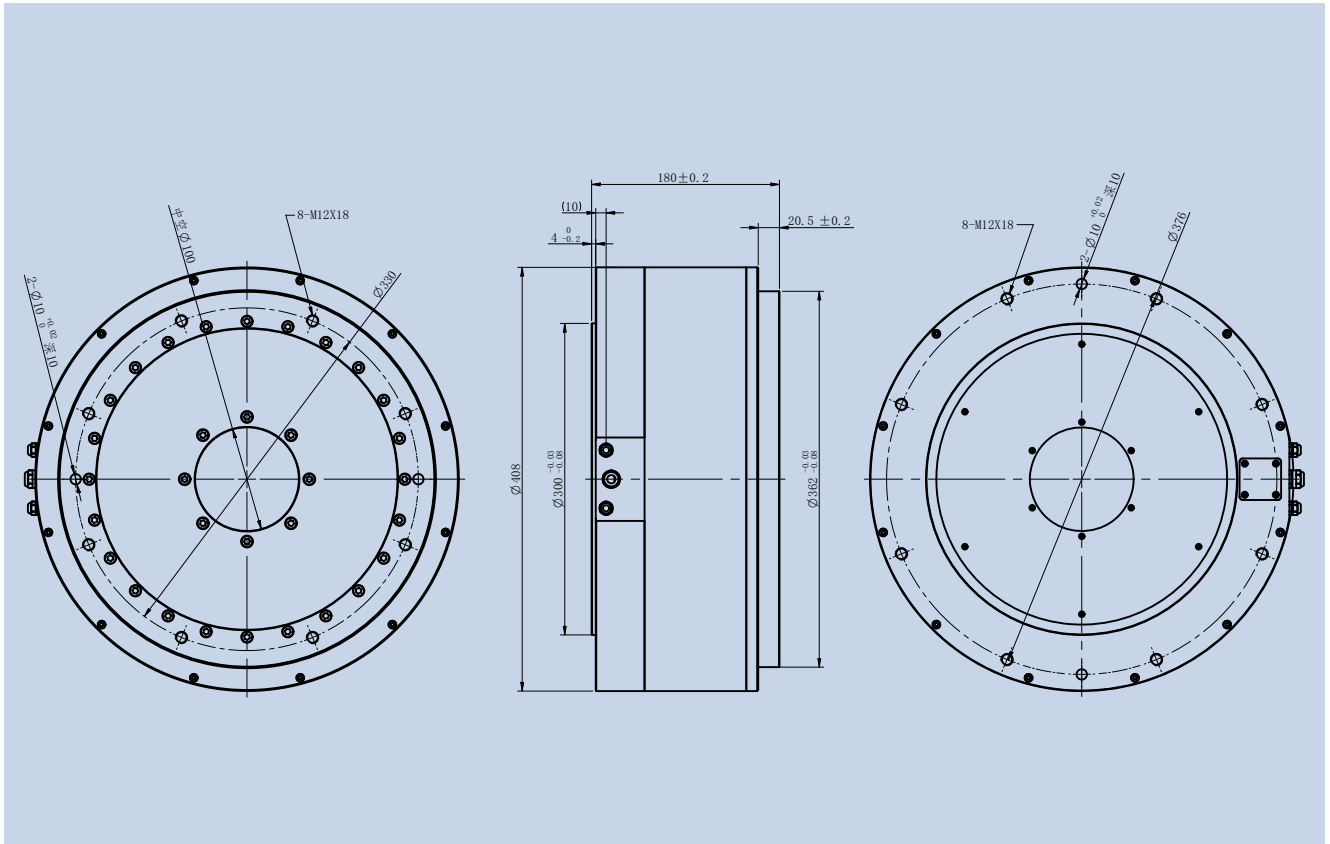

DDN-670179-C-FLJ-V2

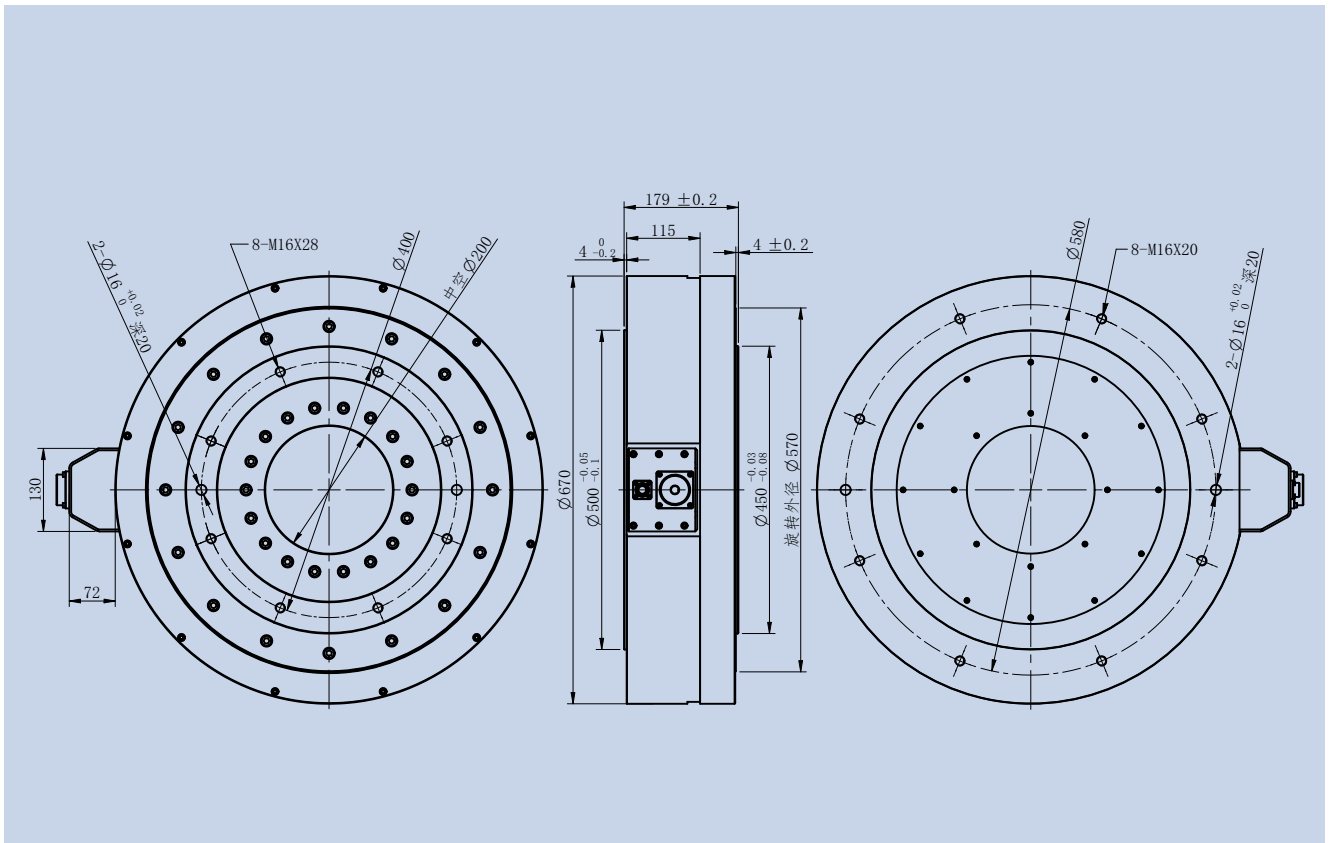

润泽福祉 诚信待人



北京润诚时代科技有限公司

地址:北京市朝阳区汤立路218号A座301

总机:010-84450370

网址:www.runcheng.net