

# EKM Series Servo Motors

## Selection Guide

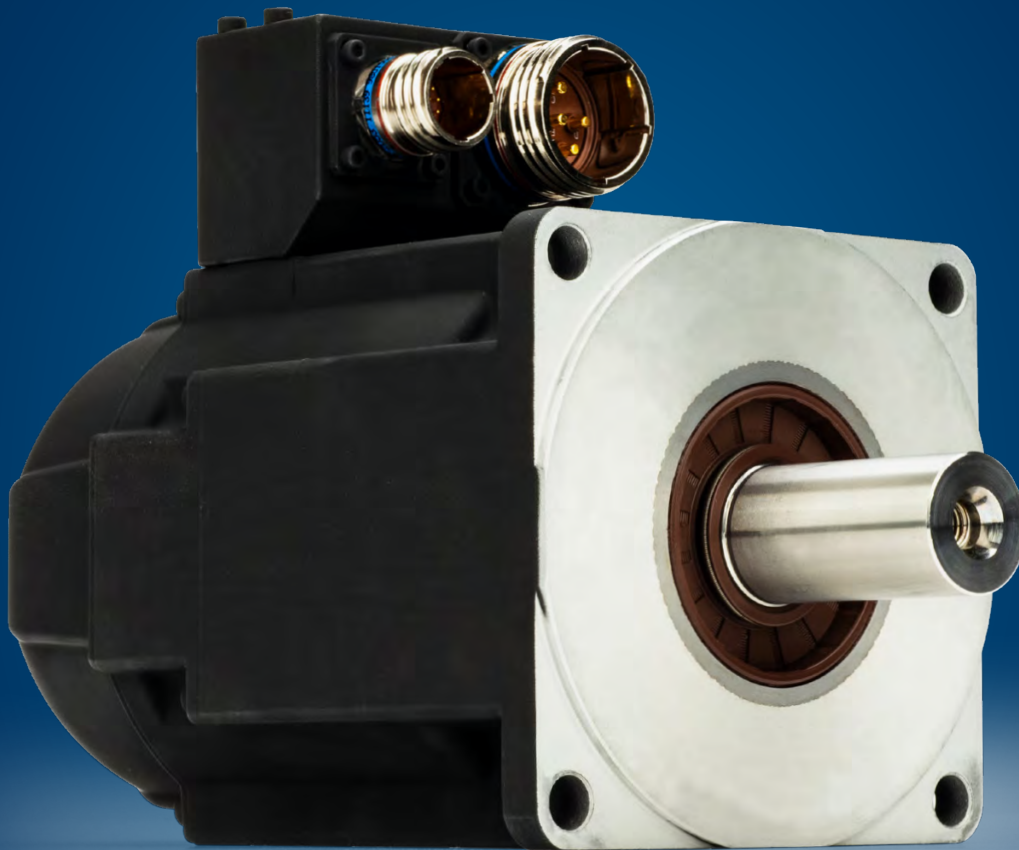

For Aerospace & Defense Applications

# **KOLLMORGEN**

北京润诚时代科技有限公司

自动化事业部

地址：北京市朝阳区汤立路218号C 座968室

邮编：100012

电话：010-84450370

传真：010-84450371

网址：[www.runcheng.net](http://www.runcheng.net)

邮箱：[.runcheng\\_emd@sina.com](mailto:.runcheng_emd@sina.com)

# Kollmorgen – Serving the Aerospace and Defense Industry

The Kollmorgen team provides aerospace and defense customers with high standards of quality, innovation and technology to improve a machine's performance and reliability. In addition, Altra Motion's global manufacturing footprint, rapid customization and prototyping capabilities drive quick lead times which empowers Kollmorgen's customers to commission their machines faster.

Kollmorgen also offers the aerospace and defense industry unparalleled depth and breadth of motion control product solutions through a worldwide service and support infrastructure made up of field service engineers and support teams that are available when and where customers need them.



**Removing the Barriers of Design, Sourcing, and Time**

At Kollmorgen, we know that OEM engineers can achieve a lot more when obstacles aren't in the way. So, we clear obstacles in three important ways:

**Integrating Standard and Custom Products**

The optimal solution is often not clear-cut. Our application expertise allows us to modify standard products or develop totally custom solutions across our whole product portfolio so that designs can take flight.

**Providing Motion Solutions, Not Just Components**

As companies reduce their supplier base and have less engineering manpower, they need a total system supplier with a wide range of integrated solutions. Kollmorgen offers complete solutions as well as motion subsystems that combine programming software, engineering services and best-in-class motion components.

**Global Footprint**

With direct sales, engineering support, manufacturing facilities, and distributors spanning the Americas, Europe, the Middle East, and Asia, we're close to OEMs worldwide. Our proximity helps speed delivery and lend support where and when they're needed.

**Financial and Operational Stability**

Kollmorgen is part of Altra Industrial Motion. A key driver in the growth of all Altra divisions is the Altra Business System, which relies on the principle of "kaizen" – or continuous improvement. Using world-class tools, cross-disciplinary teams of exceptional people evaluate processes and develop plans that result in superior performance.

**Kollmorgen: Your partner. In Motion.**

**Trademarks**

AKD is a registered trademark of Kollmorgen Corporation  
 AKM is a registered trademark of Kollmorgen Corporation  
 Cartridge DDR is a registered trademark of Kollmorgen Corporation  
 EnDat is a registered trademark of Dr. Johannes Heidenhain GmbH  
 EtherCAT is a registered trademark and patented technology, licensed by Beckhoff Automation GmbH  
 Ethernet/IP is a registered trademark of ODVA, Inc.  
 Ethernet/IP Communication Stack: copyright (c) 2009, Rockwell Automation  
 sercos® is a registered trademark of sercos® International e.V.  
 HIPERFACE and HIPERFACE DSL are registered trademarks of Max Stegmann GmbH  
 PROFINET is a registered trademark of PROFIBUS and PROFINET International (PI)  
 SIMATIC is a registered trademark of SIEMENS AG  
 SpeedTec, ytec, itec and htec are registered trademarks of TE Connectivity Ltd.  
 Windows is a registered trademark of Microsoft Corporation

**Table of Contents**

- ▶ **EKM Series Servo Motor Introduction** 4
- ▶ **EKM Series Servo Motor Quick Guide** 6
- ▶ **EKM Series Servo Motor Nomenclature** 9
- ▶ **EKM Performance and Dimension Data** 10
  - EKM2x 10
  - EKM3x 12
  - EKM4x 14
  - EKM5x 16
  - EKM6x 18
  - EKM7x 20
- ▶ **L<sub>10</sub> Bearing Fatigue Life and Shaft Fatigue Rating** 22
- ▶ **EKM Motor Resolver Feedback Details** 24
- ▶ **Failsafe, Holding Brake** 24
- ▶ **EKM Motor Connector Pinouts** 25
- ▶ **Kollmorgen Solutions** 27
  - Automation and Motion Control 27
  - Self-help Tools 27

# EKM Servo Motor Introduction

## Enhanced, High-Performance, Brushless AC Servo motors

EKM Series Motors are Mil-Spec 810E rated and IP67 sealed for duty in harsh environmental conditions.

- » Industry leading power and torque density
- » Meets IP67 sealing requirements and is 100% leak-tested housing for further moisture blocking
- » Ideal for most military specifications
- » C.O.T.S (commercial off the shelf) solution
- » Standard product offering with customization available



### Features

#### Torque

Offers 0.43 to 53 N-m continuous stall torque (3.8 to 467 lb in).

#### Speed

Speeds up to 8000 rpm meet high speed application requirements while the windings can be specifically tailored to lower speeds as well.

#### Voltage

EKM Series Motors feature 480 Vac High Voltage Insulation.

#### Feedback

Rugged Resolver feedback can survive the most extreme environments.

#### Friction Torque

Low-cog, low harmonic distortion magnetic designs.

#### Connectivity

High performance nickel-plated MIL-C-38999 connectors with total environmental sealing, quick mating, triple lead threaded, self-locking coupling, as well as EMI and RFI shielding. In addition, both front-facing and rear-facing options are available.

#### Thermal

EKM Series Motors are rated for operation over a temperature range of -51°C to 54°C and feature 155°C (class F) insulation materials which include a thermistor.

#### Corrosion

Stainless steel shaft and fasteners prevent external corrosion while a chemical agent resistant paint allows resistance to harsh outdoor environments and chemicals.

#### Sealing

IP67 rated for ingress prevention and brief submergence as well as 100-psi wash down. In addition, a viton shaft seal comes standard.

#### Shock

Tested per MIL-STD-810E, Method 516.4, Procedure 1, 75g half sine wave pulses for 11 ms, 3 times in each axis (total of 18 shocks).

#### Vibration

Tested per MIL-STD-810E, Method 514.4, Procedure 1, Operational 0.01g<sup>2</sup>/Hz 5-30Hz, 0.02g<sup>2</sup>/Hz 75-500Hz, 0.006g<sup>2</sup>/Hz 900-2000 Hz.

#### Mounting

International Standard Mount available.

#### Additional motion control solutions are available with these options:

- » Fail-safe brakes
- » Shaft variations
- » Custom windings

## Advanced Motor Design Features

The enhanced EKM motor series is Mil-Spec 810E rated, IP67 sealed, and comes standard with a stainless steel shaft and chemical-agent-resistant paint.

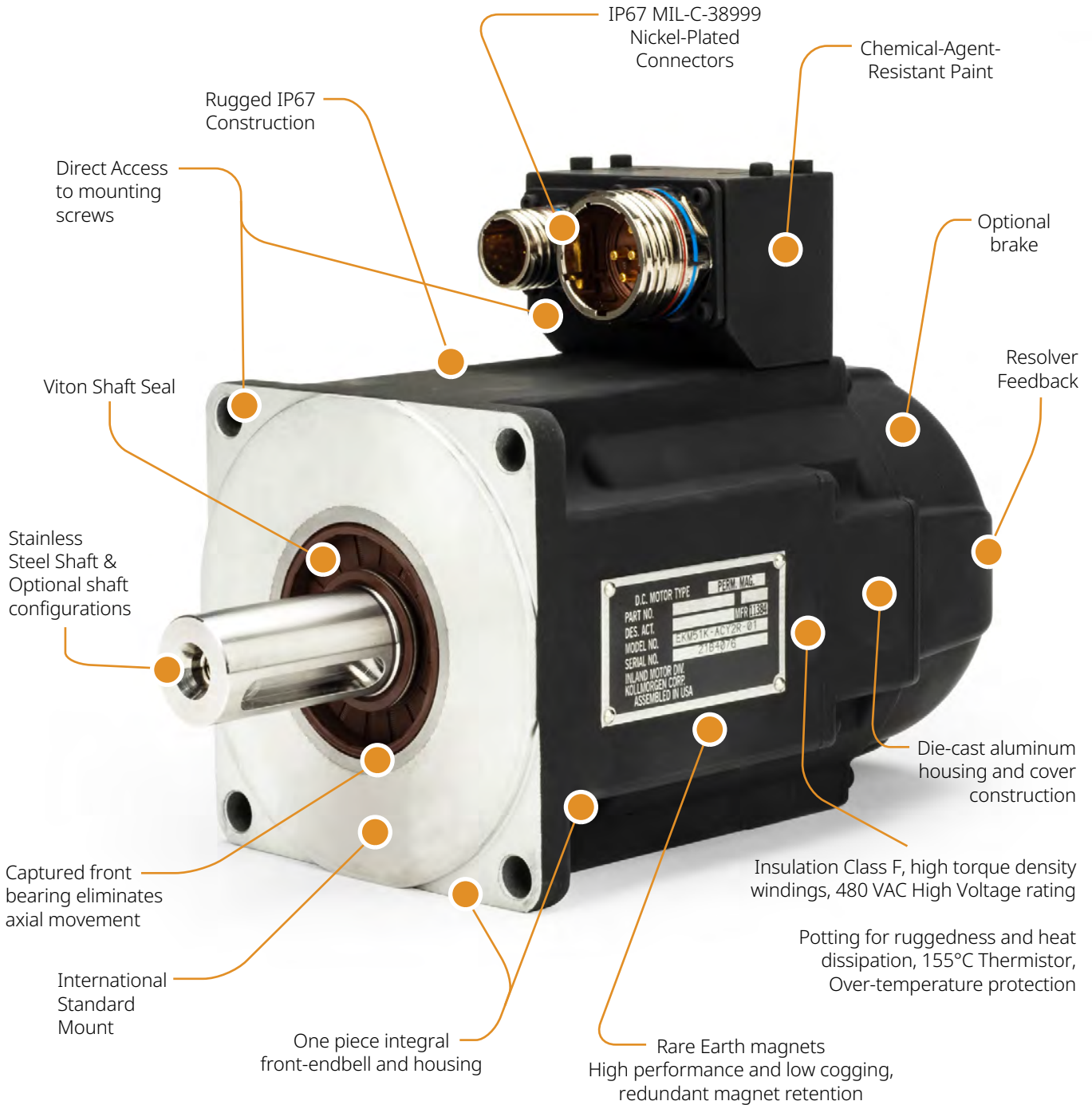

Note: The EKM Series is not CE compliant.

# EKM Servo Motor Quick Guide

## Motor Performance, 240 Vac (320 Vdc bus) assuming Sinusoidal Commutation <sup>①</sup>

Motor Model	Peak Stall Torque T <sub>ps</sub> <sup>②</sup> N-m (lb-in)	Peak Torque at Max. Speed T <sub>ms</sub> N-m (lb-in)	Cont. Stall Torque T <sub>cs</sub> N-m (lb-in)	Cont. Rated Torque T <sub>cr</sub> N-m (lb-in)	Speed at Knee ω <sub>k</sub> rpm	Rated Speed ω <sub>r</sub> rpm	Max. Speed ω <sub>max</sub> rpm	Cont. Stall Current I <sub>cs</sub> Arms	Current at Peak Torque I <sub>ps</sub> Arms
EKM21C	1.42 (12.6)	0.70 (6.22)	0.43 (3.57)	0.34 (3.02)	4,210	8,000	8,000	1.58	6.30
EKM22C	2.68 (23.7)	0.0 (0.0)	0.79 (7.02)	0.73 (6.49)	1,810	3,500	5,620	1.39	5.60
EKM22E	2.71 (24.0)	1.56 (13.8)	0.82 (7.28)	0.65 (5.77)	5,160	8,000	8,000	2.73	10.9
EKM23C	3.72 (32.9)	0.0 (0.0)	1.08 (9.58)	1.03 (9.12)	1,330	2,500	4,250	1.41	5.60
EKM23D	3.79 (33.5)	0.0 (0.0)	1.11 (9.84)	0.98 (8.69)	2,950	5,000	6,520	2.19	8.80
EKM23F	3.83 (33.9)	3.23 (28.6)	1.13 (10.0)	0.89 (7.89)	6,910	8,000	8,000	4.31	17.2
EKM24C	4.68 (41.4)	0.0 (0.0)	1.33 (11.8)	1.27 (11.27)	1,170	2,000	3,530	1.42	5.70
EKM24D	4.71 (41.7)	0.0 (0.0)	1.36 (12.0)	1.24 (11.0)	2,520	4,000	5,410	2.21	8.80
EKM24F	4.77 (42.2)	2.37 (21.0)	1.37 (12.1)	1.07 (9.49)	5,420	8,000	8,000	3.89	15.6
EKM31C	3.83 (33.9)	0.0 (0.0)	1.10 (9.76)	1.07 (9.47)	1,220	2,500	4,040	1.37	5.50
EKM31E	3.95 (34.9)	0.72 (6.39)	1.15 (10.2)	0.90 (7.98)	3,970	6,000	8,000	2.99	12.0
EKM32C	6.87 (60.8)	0.0 (0.0)	1.95 (17.3)	1.90 (16.8)	623	1,500	2,460	1.44	5.70
EKM32D	7.00 (61.9)	0.0 (0.0)	1.99 (17.6)	1.88 (16.7)	1,580	2,500	3,750	2.23	8.90
EKM32H	7.21 (63.8)	2.82 (25.0)	2.05 (18.2)	1.40 (12.4)	5,210	7,000	8,000	5.50	22.0
EKM33C	9.71 (85.9)	0.0 (0.0)	2.66 (23.6)	2.59 (22.9)	291	1,000	1,840	1.47	5.90
EKM33E	9.91 (87.6)	0.0 (0.0)	2.74 (24.3)	2.57 (22.8)	1,360	2,000	3,130	2.58	10.3
EKM33H	10.2 (89.8)	0.0 (0.0)	2.83 (25.0)	2.22 (19.7)	3,960	5,500	6,630	5.62	22.5
EKM41C	6.05 (53.6)	0.0 (0.0)	1.88 (16.6)	1.83 (16.2)	604	1,200	2,550	1.46	5.80
EKM41E	6.21 (54.9)	0.0 (0.0)	1.95 (17.2)	1.75 (15.5)	1,680	3,000	4,810	2.85	11.4
EKM41H	6.29 (55.6)	3.73 (33.0)	1.99 (17.6)	1.55 (13.7)	3,640	6,000	6,000	5.60	22.4
EKM42E	11.2 (99.3)	0.0 (0.0)	3.35 (29.6)	3.05 (27.0)	1,000	1,800	2,730	2.74	11.0
EKM42G	11.4 (101)	0.0 (0.0)	3.46 (30.6)	2.83 (25.0)	2,050	3,500	4,650	4.80	19.2
EKM42J	11.5 (102)	6.45 (57.0)	3.49 (30.8)	2.31 (20.4)	3,790	6,000	6,000	8.40	33.7
EKM43E	15.8 (140)	0.0 (0.0)	4.63 (40.9)	4.17 (36.9)	724	1,500	1,995	2.76	11.0
EKM43G	16.0 (142)	0.0 (0.0)	4.73 (41.8)	3.93 (34.7)	1,600	2,500	3,460	4.87	19.5
EKM43K	16.2 (143)	5.37 (47.5)	4.83 (42.7)	2.55 (22.5)	3,410	6,000	6,000	9.60	38.3
EKM44E	19.8 (175)	0.0 (0.0)	5.69 (50.3)	5.13 (45.3)	655	1,200	1,677	2.85	11.4
EKM44G	20.1 (178)	0.0 (0.0)	5.81 (51.4)	4.83 (42.7)	1,400	2,000	2,885	5.00	20.0
EKM44J	20.3 (180)	0.0 (0.0)	5.93 (52.4)	3.77 (33.3)	2,680	4,000	5,005	8.80	35.2
EKM51E	11.5 (101)	0.0 (0.0)	4.57 (40.4)	4.28 (37.8)	917	1,200	2,000	2.75	28.3
EKM51G	11.6 (102)	0.0 (0.0)	4.62 (40.8)	3.90 (34.5)	1,900	2,500	3,470	4.84	14.5
EKM51K	11.9 (105)	4.30 (38.0)	4.77 (42.2)	2.22 (19.6)	3,830	5,500	6,000	9.40	28.3
EKM52G	21.4 (189)	0.0 (0.0)	8.30 (73.4)	7.56 (66.8)	1,090	1,500	1,915	4.72	14.2
EKM52K	21.8 (193)	0.0 (0.0)	8.47 (74.9)	6.67 (59.0)	2,360	3,000	3,685	9.30	27.8
EKM52M	21.8 (193)	0.0 (0.0)	8.47 (74.9)	5.07 (44.8)	3,440	4,500	5,220	13.1	39.4
EKM53G	29.6 (262)	0.0 (0.0)	11.3 (99.7)	10.6 (93.5)	841	1,000	1,440	4.77	14.3
EKM53K	30.0 (265)	0.0 (0.0)	11.5 (101)	9.97 (88.1)	1,870	2,000	2,780	9.40	28.1
EKM53M	29.7 (263)	0.0 (0.0)	11.3 (99.7)	8.59 (76.1)	2,860	3,000	4,050	13.4	40.3
EKM53P	29.7 (263)	0.0 (0.0)	11.3 (99.7)	5.75 (50.9)	4,200	5,000	5,770	19.1	57.4
EKM54K	38.3 (338)	0.0 (0.0)	14.3 (126)	12.6 (111)	1,570	1,800	2,290	9.70	29.2
EKM54L	37.4 (330)	0.0 (0.0)	14.0 (123)	11.4 (101)	2,200	2,500	3,040	12.5	37.5
EKM54N	37.5 (331)	0.0 (0.0)	14.0 (123)	9.72 (85.9)	3,170	3,500	4,320	17.8	53.4
EKM62K	29.9 (264)	0.0 (0.0)	12.0 (105)	10.2 (89.7)	1,470	2,000	2,700	9.60	28.7
EKM62M	30.0 (265)	0.0 (0.0)	12.0 (105)	9.25 (81.8)	2,100	3,000	3,770	13.4	40.3
EKM62P	30.2 (267)	0.0 (0.0)	12.1 (106)	7.85 (69.4)	3,040	4,500	5,250	18.8	56.5
EKM63K	42.2 (374)	0.0 (0.0)	16.6 (146)	14.7 (129)	1,200	1,500	2,020	9.90	29.7
EKM63M	42.8 (378)	0.0 (0.0)	16.8 (148)	14.1 (124)	1,700	2,000	2,770	13.8	41.4
EKM63N	42.8 (378)	0.0 (0.0)	16.8 (148)	12.8 (113)	2,180	3,000	3,500	17.4	52.2
EKM64K	53.3 (471)	0.0 (0.0)	20.6 (182)	19.0 (168)	932	1,200	1,510	9.20	27.5
EKM64L	53.9 (476)	0.0 (0.0)	20.8 (183)	18.2 (160)	1,340	1,500	2,080	12.8	38.4
EKM64P	52.7 (465)	0.0 (0.0)	20.2 (178)	15.8 (139)	2,100	2,500	3,120	18.6	55.9
EKM65K	64.3 (568)	0.0 (0.0)	24.6 (217)	22.6 (199)	859	1,000	1,350	9.80	29.4
EKM65M	65.0 (574)	0.0 (0.0)	24.8 (219)	21.7 (191)	1,230	1,500	1,860	13.6	40.9
EKM65N	63.5 (561)	0.0 (0.0)	24.1 (213)	19.6 (173)	1,720	2,000	2,500	17.8	53.3
EKM72P	78.3 (692)	0.0 (0.0)	29.2 (258)	23.6 (208)	1,300	1,800	2,170	18.7	56.1
EKM73P	111 (979)	0.0 (0.0)	41.4 (365)	34.5 (305)	1,010	1,300	1,610	19.5	58.6

① See detailed motor specifications beginning on page 10.

② Peak torque ratings are for 5 seconds.

## Motor Performance, 400 Vac (560 Vdc bus) assuming Sinusoidal Commutation <sup>①</sup>

Motor Model	Peak Stall Torque T <sub>ps</sub> <sup>②</sup> N-m (lb-in)	Peak Torque at Max. Speed T <sub>ms</sub> N-m (lb-in)	Cont. Stall Torque T <sub>cs</sub> N-m (lb-in)	Cont. Rated Torque T <sub>cr</sub> N-m (lb-in)	Speed at Knee ω <sub>k</sub> rpm	Rated Speed ω <sub>r</sub> rpm	Max. Speed ω <sub>max</sub> rpm	Cont. Stall Current I <sub>cs</sub> Arms	Current at Peak Torque I <sub>ps</sub> Arms
EKM22C	2.68 (23.7)	1.25 (11.1)	0.79 (7.01)	0.63 (5.60)	4,560	8,000	8,000	1.39	5.60
EKM23C	3.72 (32.9)	0.0 (0.0)	1.08 (9.57)	0.94 (8.34)	3,610	5,500	7,450	1.41	5.60
EKM23D	3.79 (33.5)	2.82 (25.0)	1.11 (9.84)	0.87 (7.72)	6,240	8,000	8,000	2.19	8.80
EKM24C	4.68 (41.4)	0.0 (0.0)	1.33 (11.8)	1.20 (10.6)	3,160	4,500	6,190	1.42	5.70
EKM24D	4.71 (41.6)	2.43 (21.5)	1.36 (12.1)	1.06 (9.40)	5,430	8,000	8,000	2.21	8.80
EKM31C	3.83 (33.9)	0.0 (0.0)	1.10 (9.75)	0.95 (8.42)	3,220	5,000	7,090	1.37	5.50
EKM32C	6.87 (60.8)	0.0 (0.0)	1.95 (17.3)	1.81 (16.0)	2,050	3,000	4,310	1.44	5.70
EKM32D	7.00 (61.9)	0.0 (0.0)	1.99 (17.6)	1.60 (14.2)	3,610	5,500	6,560	2.23	8.90
EKM33C	9.71 (85.9)	0.0 (0.0)	2.66 (23.5)	2.49 (22.0)	1,460	2,000	3,230	1.47	5.90
EKM33E	9.91 (87.6)	0.0 (0.0)	2.74 (24.3)	2.29 (20.3)	3,170	4,500	5,490	2.58	10.3
EKM41C	6.05 (53.5)	0.0 (0.0)	1.88 (16.6)	1.70 (15.0)	1,580	3,000	4,480	1.46	5.80
EKM41E	6.21 (54.9)	3.22 (28.5)	1.95 (17.2)	1.51 (13.3)	3,330	6,000	6,000	2.85	11.4
EKM42C	11.0 (97.5)	0.0 (0.0)	3.28 (29.0)	3.03 (26.8)	910	1,500	2,510	1.40	5.61
EKM42E	11.2 (99.3)	0.0 (0.0)	3.35 (29.6)	2.74 (24.2)	2,130	3,500	4,790	2.74	11.0
EKM42G	11.4 (101)	6.64 (58.7)	3.46 (30.6)	2.28 (20.2)	3,890	6,000	6,000	4.80	19.2
EKM43E	15.8 (140)	0 (0)	4.63 (40.9)	3.85 (34.0)	1,640	2,500	3,490	2.76	11.0
EKM43G	16.0 (142)	1.18 (10.4)	4.73 (41.8)	2.94 (26.0)	3,100	5,000	6,000	4.87	19.5
EKM44E	19.8 (175)	0.0 (0.0)	5.69 (50.3)	4.73 (41.8)	1,470	2,000	2,945	2.85	11.4
EKM44G	20.1 (178)	0.0 (0.0)	5.81 (51.4)	3.69 (32.6)	2,730	4,000	5,050	5.00	20.0
EKM44J	20.3 (180)	15.9 (141)	5.93 (52.4)	2.68 (23.7)	4,960	6,000	6,000	8.80	35.2
EKM51E	11.5 (101)	0.0 (0.0)	4.57 (40.4)	3.85 (34.0)	1,920	2,500	3,490	2.75	8.24
EKM51G	11.6 (102)	1.13 (9.99)	4.62 (40.8)	2.49 (22.0)	3,580	5,000	6,000	4.84	14.5
EKM52E	21.2 (187)	0.0 (0.0)	8.21 (72.6)	7.48 (66.1)	1,280	1,500	2,150	3.00	9.00
EKM52G	21.4 (189)	0.0 (0.0)	8.30 (73.4)	6.93 (61.3)	2,130	2,500	3,350	4.72	14.2
EKM52K	21.8 (192)	8.39 (74.2)	8.47 (74.9)	3.77 (33.3)	4,330	5,500	6,000	9.30	27.8
EKM53G	29.6 (261)	0.0 (0.0)	11.3 (99.6)	9.72 (85.9)	1,680	2,000	2,515	4.77	14.3
EKM53K	30.0 (265)	0.0 (0.0)	11.5 (101)	7.52 (66.5)	3,470	4,000	4,855	9.40	28.1
EKM54G	37.7 (333)	0.0 (0.0)	14.2 (125)	12.8 (113)	1,420	1,500	2,085	5.00	14.9
EKM54K	38.3 (338)	0.0 (0.0)	14.3 (126)	9.97 (88.1)	2,940	3,500	4,015	9.70	29.2
EKM54L	37.4 (330)	0.0 (0.0)	14.0 (124)	8.00 (70.7)	4,030	4,500	5,315	12.5	37.5
EKM62G	29.6 (261)	0.0 (0.0)	11.7 (103)	10.2 (89.7)	1,330	1,800	2,430	4.85	14.6
EKM62K	29.9 (263)	0.0 (0.0)	12.0 (106)	8.76 (77.4)	2,710	3,500	4,705	9.60	28.7
EKM62M	30.0 (264)	11.2 (98.6)	12.0 (106)	5.49 (48.5)	3,810	6,000	6,000	13.4	40.3
EKM63G	41.6 (367)	0.0 (0.0)	16.3 (144)	14.8 (130)	941	1,200	1,625	4.48	13.4
EKM63K	42.4 (374)	0.0 (0.0)	16.6 (146)	12.7 (112)	2,230	3,000	3,520	9.90	29.7
EKM63M	42.8 (378)	0.0 (0.0)	16.8 (148)	11.1 (97.7)	3,100	4,000	4,840	13.8	41.4
EKM63N	42.8 (378)	7.50 (66.3)	16.8 (148)	9.35 (82.7)	3,940	5,000	6,000	17.4	52.2
EKM64K	53.3 (471)	0.0 (0.0)	20.6 (182)	17.0 (150)	1,760	2,000	2,645	9.20	27.5
EKM64L	53.9 (476)	0.0 (0.0)	20.8 (183)	15.4 (136)	2,470	3,000	3,635	12.8	38.4
EKM64P	52.7 (465)	0.0 (0.0)	20.2 (178)	11.7 (103)	3,810	4,500	5,455	18.6	55.9
EKM65K	64.3 (568)	0.0 (0.0)	24.6 (217)	20.0 (176)	1,630	2,000	2,365	9.80	29.4
EKM65M	65.0 (574)	0.0 (0.0)	24.8 (219)	19.0 (168)	2,280	2,500	3,245	13.6	40.9
EKM65N	63.5 (561)	0.0 (0.0)	24.1 (213)	15.8 (139)	3,150	3,500	4,365	17.8	53.3
EKM72K	79.0 (698)	0.0 (0.0)	29.5 (260)	25.0 (220)	1,100	1,500	1,855	9.30	27.8
EKM72M	79.5 (702)	0.0 (0.0)	29.8 (263)	23.4 (206)	1,560	2,000	2,585	13.0	38.9
EKM72P	78.3 (691)	0.0 (0.0)	29.2 (258)	19.9 (175)	2,350	3,000	3,795	18.7	56.1
EKM73M	113 (997)	0.0 (0.0)	41.8 (369)	33.6 (297)	1,230	1,500	1,935	13.6	40.8
EKM73P	111 (979)	0.0 (0.0)	41.4 (366)	28.3 (250)	1,830	2,400	2,825	19.5	58.6
EKM74L	143 (1262)	0.0 (0.0)	52.8 (466)	45.3 (400)	941	1,200	1,455	12.9	38.7
EKM74P	142 (1253)	0.0 (0.0)	52.3 (462)	37.4 (330)	1,420	1,800	2,115	18.5	55.5

① See detailed motor specifications beginning on page 10.

② Peak torque ratings are for 5 seconds.

# EKM Servo Motor Quick Guide

## Motor Performance, 480 Vac (640 Vdc bus) assuming Sinusoidal Commutation <sup>①</sup>

Motor Model	Peak Stall Torque T <sub>ps</sub> <sup>②</sup> N-m (lb-in)	Peak Torque at Max. Speed T <sub>ms</sub> N-m (lb-in)	Cont. Stall Torque T <sub>cs</sub> N-m (lb-in)	Cont. Rated Torque T <sub>cr</sub> N-m (lb-in)	Speed at Knee ω <sub>k</sub> rpm	Rated Speed ω <sub>r</sub> rpm	Max. Speed ω <sub>max</sub> rpm	Cont. Stall Current I <sub>cs</sub> Arms	Current at Peak Torque I <sub>ps</sub> Arms
EKM22C	2.68 (23.7)	1.71 (15.1)	0.79 (7.01)	0.63 (5.60)	5,440	8,000	8,000	1.39	5.60
EKM23C	3.72 (32.9)	0.80 (7.1)	1.08 (9.57)	0.90 (7.98)	4,340	7,000	8,000	1.41	5.60
EKM23D	3.79 (33.5)	2.82 (25.0)	1.11 (9.84)	0.87 (7.72)	7,320	8,000	8,000	2.19	8.80
EKM24C	4.68 (41.4)	0.0 (0.0)	1.33 (11.8)	1.17 (10.4)	3,800	5,500	7,080	1.42	5.70
EKM24D	4.71 (41.7)	3.46 (30.6)	1.36 (12.0)	1.06 (9.4)	6,390	8,000	8,000	2.21	8.80
EKM31C	3.83 (33.9)	0.21 (1.88)	1.10 (9.75)	0.86 (7.63)	3,850	6,000	7,990	1.37	5.50
EKM32C	6.87 (60.8)	0.0 (0.0)	1.95 (17.3)	1.78 (15.8)	2,510	3,500	4,930	1.44	5.70
EKM32D	7.00 (61.9)	0.0 (0.0)	1.99 (17.6)	1.53 (13.6)	4,280	6,000	7,500	2.23	8.90
EKM33C	9.71 (85.9)	0.0 (0.0)	2.66 (23.5)	2.45 (21.7)	1,820	2,500	3,680	1.47	5.90
EKM33E	9.91 (87.6)	0.0 (0.0)	2.74 (24.2)	2.22 (19.7)	3,760	5,000	6,270	2.58	10.3
EKM41C	6.05 (53.5)	0.0 (0.0)	1.88 (16.6)	1.67 (14.8)	1,880	3,500	5,120	1.46	5.80
EKM41E	6.21 (54.9)	4.01 (35.4)	1.95 (17.2)	1.51 (13.3)	3,870	6,000	5,990	2.85	11.4
EKM42C	11.0 (97.5)	0.0 (0.0)	3.28 (29)	2.95 (26.1)	1,120	2,000	2,870	1.40	5.61
EKM42E	11.2 (99.3)	0.0 (0.0)	3.35 (29.6)	2.65 (23.4)	2,500	4,000	5,470	2.74	11.0
EKM42G	11.4 (101)	7.92 (70.0)	3.46 (30.6)	2.28 (20.1)	4,500	6,000	6,000	4.80	19.2
EKM43E	15.8 (140)	0.0 (0.0)	4.63 (40.9)	3.69 (32.6)	1,930	3,000	4,000	2.76	11.0
EKM43G	16.0 (142)	6.68 (59.0)	4.73 (41.8)	2.50 (22.1)	3,600	6,000	6,000	4.87	19.5
EKM44E	19.8 (175)	0.0 (0.0)	5.69 (50.3)	4.49 (39.7)	1,730	2,500	3,370	2.85	11.4
EKM44G	20.1 (178)	0.0 (0.0)	5.81 (51.4)	3.12 (27.6)	3,180	5,000	5,780	5.00	20.0
EKM44J	20.3 (180)	18 (159)	5.93 (52.4)	2.68 (23.7)	5,720	6,000	6,000	8.80	35.2
EKM51E	11.5 (101)	0.0 (0.0)	4.57 (40.4)	3.67 (32.4)	2,240	3,000	4,010	2.75	8.24
EKM51G	11.6 (102)	5.81 (51.4)	4.62 (40.8)	1.81 (16)	4,140	6,000	6,000	4.84	14.5
EKM52E	21.2 (187)	0.0 (0.0)	8.21 (72.6)	7.15 (63.2)	1,500	2,000	2,470	3.00	9.00
EKM52G	21.4 (189)	0.0 (0.0)	8.30 (73.4)	6.53 (57.7)	2,480	3,000	3,840	4.72	14.2
EKM52K	21.8 (192)	15.7 (139)	8.47 (74.9)	3.12 (27.6)	4,990	6,000	6,000	9.30	27.8
EKM53G	29.6 (261)	0.0 (0.0)	11.3 (100)	9.37 (82.8)	1,960	2,400	2,880	4.77	14.3
EKM53K	30 (265)	0.0 (0.0)	11.5 (101)	6.72 (59.4)	4,000	4,500	5,550	9.40	28.1
EKM54G	37.7 (333)	0.0 (0.0)	14.2 (125)	12.2 (108)	1,660	2,000	2,390	5.00	14.9
EKM54K	38.3 (338)	0.0 (0.0)	14.3 (126)	9.12 (80.6)	3,390	4,000	4,590	9.70	29.2
EKM62G	29.6 (261)	0.0 (0.0)	11.7 (103)	10.0 (88.0)	1,550	2,000	2,790	4.85	14.6
EKM62K	29.9 (264)	0.0 (0.0)	12.0 (106)	7.77 (68.7)	3,130	4,500	5,400	9.60	28.7
EKM62M	30.0 (265)	18.6 (164)	12.0 (106)	5.49 (48.5)	4,380	6,000	6,000	13.4	40.3
EKM63G	41.6 (367)	0.0 (0.0)	16.3 (144)	14.4 (127)	1,100	1,500	1,860	4.48	13.4
EKM63K	42.4 (374)	0.0 (0.0)	16.6 (146)	11.8 (104)	2,570	3,500	4,030	9.90	29.7
EKM63M	42.8 (378)	0.0 (0.0)	16.8 (148)	10.3 (90.6)	3,570	4,500	5,550	13.8	41.4
EKM63N	42.8 (378)	24.4 (215)	16.8 (148)	6.75 (59.7)	4,530	6,000	6,000	17.4	52.2
EKM64K	53.3 (471)	0.0 (0.0)	20.6 (182)	16.1 (142)	2,040	2,500	3,030	9.20	27.5
EKM64L	53.9 (476)	0.0 (0.0)	20.8 (183)	14.2 (125)	2,850	3,500	4,160	12.8	38.4
EKM64P	52.7 (465)	15.4 (136)	20.2 (178)	8.80 (78.0)	4,380	5,500	6,000	18.6	55.9
EKM65K	64.3 (568)	0.0 (0.0)	24.6 (217)	19.5 (172)	1,890	2,200	2,710	9.80	29.4
EKM65M	65.0 (574)	0.0 (0.0)	24.8 (219)	17.9 (158)	2,620	3,000	3,720	13.6	40.9
EKM65N	63.5 (561)	0.0 (0.0)	24.1 (213)	14.5 (128)	3,620	4,000	4,990	17.8	53.3
EKM72K	79.0 (698)	0.0 (0.0)	29.5 (260)	23.8 (210)	1,270	1,800	2,130	9.30	27.8
EKM72M	79.5 (702)	0.0 (0.0)	29.8 (263)	21.9 (193)	1,790	2,500	2,960	13.0	38.9
EKM72P	78.3 (692)	0.0 (0.0)	29.2 (258)	18.0 (159)	2,700	3,500	4,350	18.7	56.1
EKM73M	113 (997)	0.0 (0.0)	41.8 (369)	31.9 (282)	1,420	1,800	2,220	13.6	40.8
EKM73P	111 (979)	0.0 (0.0)	41.4 (366)	26.1 (230)	2,100	2,800	3,230	19.5	58.6
EKM74L	143 (1262)	0.0 (0.0)	52.8 (466)	41.3 (365)	1,090	1,400	1,670	12.9	38.7
EKM74P	142 (1253)	0.0 (0.0)	52.3 (462)	35.7 (315)	1,630	2,000	2,420	18.5	55.5

① See detailed motor specifications beginning on page 10.

② Peak torque ratings are for 5 seconds.



# EKM Model Nomenclature

## EKM Brushless Servo Motor

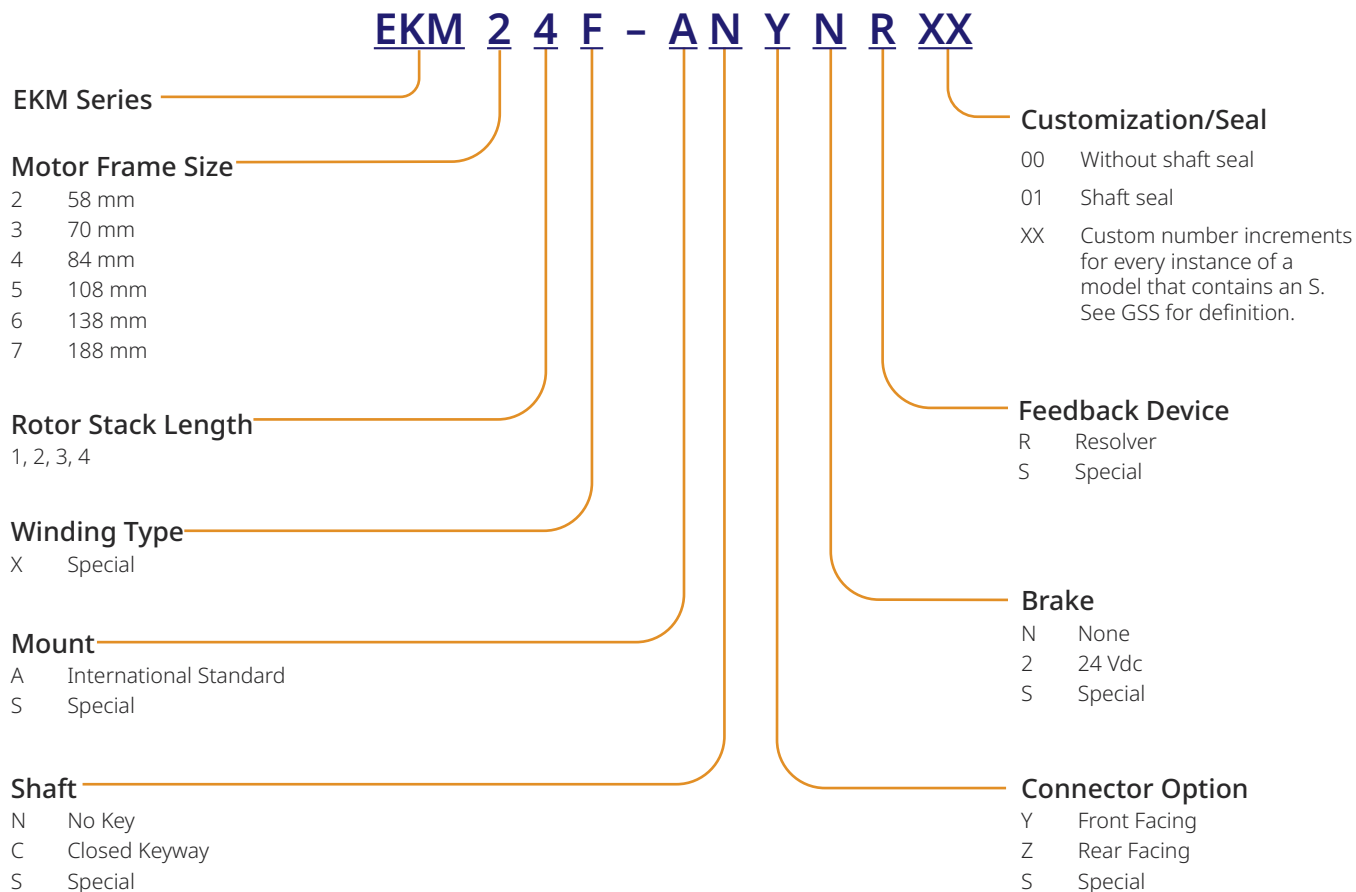

# EKM Servo Motor Specifications

## EKM2x Performance Data – Up to 480 Vac (640 Vdc bus) voltage

Performance & Parameters	Symbol	Units	EKM21			EKM22			EKM23			EKM24				
			Windings			Windings			Windings			Windings				
			C	E	G	C	E	G	C	D	F	C	D	F		
Max Rated Voltage	-	Vac	240	120	-	480	240	120	480	480	240	480	480	240		
		Vdc	320	160	75	640	320	160	640	640	320	640	640	320		
Continuous (Stall) Torque ⑤	Tcs	N-m	0.433	0.453	0.453	0.793	0.823	0.833	1.08	1.11	1.13	1.33	1.36	1.37		
		lb-in	3.83	4.01	4.01	7.02	7.29	7.38	9.59	9.86	10.03	11.8	12.1	12.2		
Continuous (Stall) Current	Ics	Arms	1.58	3.11	4.87	1.39	2.73	4.82	1.41	2.19	4.31	1.42	2.21	3.89		
		Adc	1.94	3.81	5.97	1.70	3.34	5.90	1.73	2.68	5.28	1.74	2.71	4.73		
Peak Torque	Tp	N-m	1.42	1.44	1.46	2.68	2.71	2.74	3.72	3.79	3.83	4.68	4.71	4.77		
		lb-in	12.6	12.7	12.9	23.7	24.0	24.3	32.9	33.6	33.9	41.4	41.7	42.2		
Peak Current	Ip	Arms	6.30	12.4	19.5	5.60	10.9	19.3	5.60	8.80	17.2	5.70	8.80	15.6		
		Adc	7.72	15.2	23.9	6.86	13.4	23.6	6.86	10.8	21.1	6.98	10.8	19.1		
Torque Constant at 140°C	Kt	N-m / Arms	0.30	0.16	0.10	0.61	0.32	0.18	0.80	0.52	0.27	0.97	0.63	0.36		
		lb-in / Arms	2.7	1.4	0.9	5.4	2.8	1.6	7.1	4.6	2.4	8.6	5.6	3.2		
BEMF Constant ②	Ke	Vrms / Krpm	19.5	10.2	6.6	39.0	20.4	11.7	51.8	33.8	17.6	62.4	40.8	23.4		
Resistance ②	Rm	Ohms	13.0	3.42	1.44	20.0	5.22	1.77	21.2	8.77	2.34	20.4	9.02	2.94		
Inductance ②	mH	mH	19	5.2	2.2	36	10	3.2	41	17	4.7	44	19	6.2		
75 VDC	Rated Speed ① ③	Nrtd	rpm	-	2000	4000	-	1000	2500	-	-	1500	-	-	1000	
		Rated Torque ① ③ ⑤	Trtd	N-m	-	0.433	0.413	-	0.803	0.783	-	-	1.10	-	-	1.34
				lb-in	-	3.83	3.66	-	7.11	6.93	-	-	9.77	-	-	11.9
Rated Power ① ③	Prtd	kW	-	0.091	0.17	-	0.084	0.20	-	-	0.17	-	-	0.14		
		Hp	-	0.12	0.23	-	0.11	0.27	-	-	0.23	-	-	0.19		
120 Vac (160 Vdc)	Rated Speed ① ③	Nrtd	rpm	2500	7000	-	1000	3500	7000	1000	1500	4500	-	1500	3000	
		Rated Torque ① ③ ⑤	Trtd	N-m	0.413	0.363	-	0.783	0.763	0.693	1.06	1.07	1.02	-	1.31	1.28
				lb-in	3.66	3.21	-	6.93	6.76	6.14	9.41	9.50	9.06	-	11.6	11.4
Rated Power ① ③	Prtd	kW	0.11	0.27	-	0.082	0.28	0.51	0.11	0.17	0.48	-	0.21	0.40		
		Hp	0.14	0.36	-	0.11	0.37	0.68	0.15	0.23	0.65	-	0.28	0.54		
240 Vac (320 Vdc)	Rated Speed ① ③	Nrtd	rpm	8000	-	-	3500	8000	-	2500	5000	8000	2000	4000	8000	
		Rated Torque ① ③ ⑤	Trtd	N-m	0.343	-	-	0.733	0.653	-	1.03	0.983	0.893	1.27	1.24	1.07
				lb-in	3.04	-	-	6.49	5.78	-	9.15	8.71	7.91	11.3	11.0	9.50
Rated Power ① ③	Prtd	kW	0.29	-	-	0.27	0.55	-	0.27	0.51	0.75	0.27	0.52	0.90		
		Hp	0.39	-	-	0.36	0.73	-	0.36	0.69	1.00	0.36	0.70	1.20		
400 Vac (560 Vdc)	Rated Speed ① ③	Nrtd	rpm	-	-	-	8000	-	-	5500	8000	-	4500	8000	-	
		Rated Torque ① ③ ⑤	Trtd	N-m	-	-	-	0.633	-	-	0.943	0.873	-	1.20	1.06	-
				lb-in	-	-	-	5.61	-	-	8.35	7.73	-	10.7	9.41	-
Rated Power ① ③	Prtd	kW	-	-	-	0.53	-	-	0.54	0.73	-	0.57	0.89	-		
		Hp	-	-	-	0.71	-	-	0.73	0.98	-	0.76	1.19	-		
480 Vac (640 Vdc)	Rated Speed ① ③	Nrtd	rpm	-	-	-	8000	-	-	7000	8000	-	5500	8000	-	
		Rated Torque ① ③ ⑤	Trtd	N-m	-	-	-	0.633	-	-	0.903	0.873	-	1.17	1.06	-
				lb-in	-	-	-	5.61	-	-	8.00	7.73	-	10.39	9.41	-
Rated Power ① ③	Prtd	kW	-	-	-	0.53	-	-	0.66	0.73	-	0.68	0.89	-		
		Hp	-	-	-	0.71	-	-	0.89	0.98	-	0.91	1.19	-		
Inertia (includes resolver)	Jm	kg-cm <sup>2</sup>	0.11			0.16			0.22			0.27				
		lb-in-s <sup>2</sup>	9.50E-05			1.40E-04			1.90E-04			2.40E-04				
Brake Inertia (additional)	Jm	kg-cm <sup>2</sup>	0.012			0.012			0.012			0.012				
		lb-in-s <sup>2</sup>	1.10E-05			1.10E-05			1.10E-05			1.10E-05				
Static Friction (includes shaft seal)	Tf	N-m	0.049			0.052			0.054			0.057				
		lb-in	0.434			0.461			0.478			0.505				
Viscous Damping	Kdv	N-m / krpm	0.0046			0.0055			0.0065			0.0074				
		lb-in / krpm	0.04			0.05			0.06			0.07				
Weight ⑥	W	kg	0.91			1.18			1.45			1.77				
		lb	2.00			2.60			3.20			3.90				
Thermal Time Constant	TCT	minutes	8			9			10			11				
Thermal Resistance	Rth	°C / Watt	1.43			1.19			1.10			1.07				
Heat Sink Size	Aluminum	inch	10" x 10" x 1/4"			10" x 10" x 1/4"			10" x 10" x 1/4"			10" x 10" x 1/4"				
Poles Pair			3			3			3			3				
Maximum Mechanical Speed ④	Nmax	rpm	8,000			8,000			8,000			8,000				

Notes:

① Motor Performance based on  $\Delta T = 100^\circ C$  in a  $40^\circ C$  ambient (winding temp =  $140^\circ C$ ) with listed Heat Sink.

② Motor Parameters BEMF, Resistance, and Inductance measured at  $25^\circ C$ .

③ All data referenced to sinusoidal commutation.

④ Speed may be limited by Vbus.

⑤ Brake option reduces continuous torque by: EKM21 = 0.0 Nm, EKM22 = 0.01 Nm, EKM23 = 0.02 Nm, EKM24 = 0.05 Nm

⑥ Motor weight does not include brake option. EKM2 brake adds 0.27 kg (0.59 lb).

### EKM2x Frame Dimensional Drawings

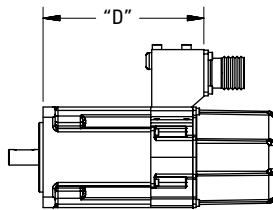
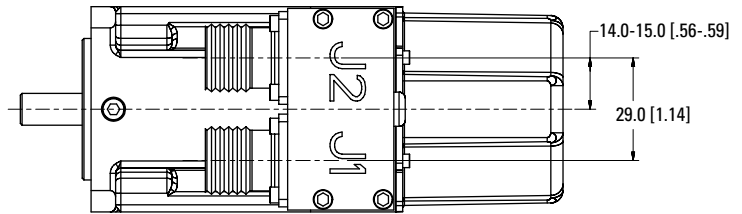
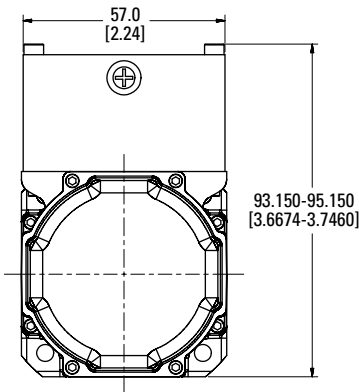
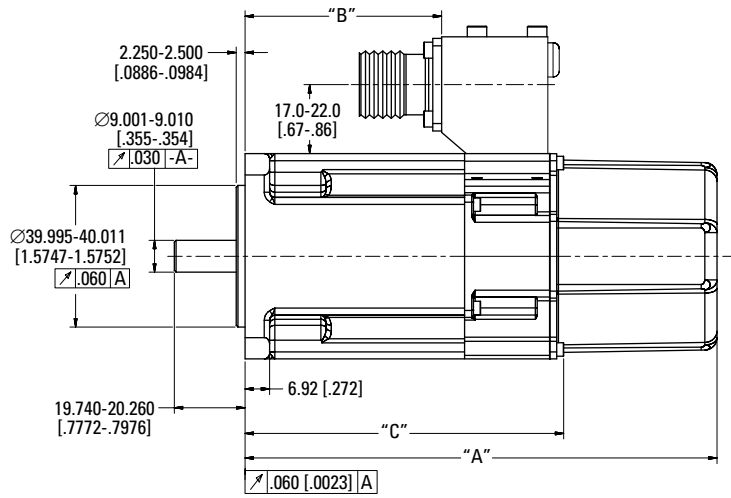
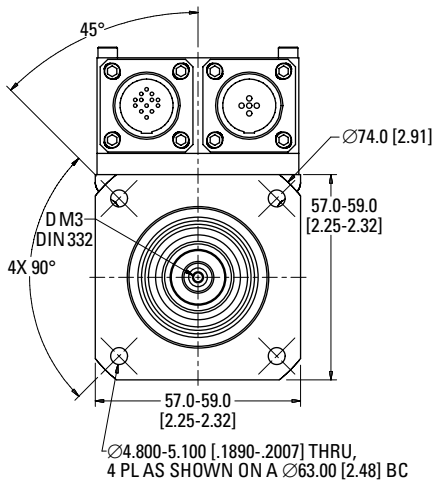

REAR CONNECTOR MOUNTING OPTION

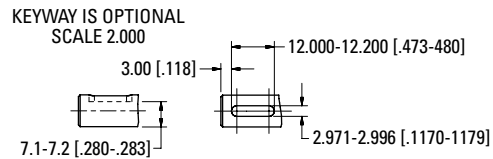

Model	"A"	"B"	"C"	"D"
EKM21	132.35 - 134.35	54.0 - 57.0	89.05 - 91.05	91.0 - 94.0
EKM22	151.35 - 153.35	73.0 - 75.0	108.05 - 110.05	110.0 - 113.0
EKM23	170.35 - 172.35	92.0 - 95.0	127.05 - 129.05	129.0 - 132.0
EKM24	189.35 - 191.35	111.0 - 114.0	146.05 - 148.05	148.0 - 151.0

Dimensions are in mm [inches].  
 Product designed in metric.  
 English conversions provided for reference only.

\*Complete EKM series model nomenclature can be found on page 9.

# EKM Servo Motor Specifications

## EKM3x Performance Data – Up to 480 Vac (640 Vdc bus) voltage

Performance & Parameters	Symbol	Units	EKM31			EKM32			EKM33			
			Windings			Windings			Windings			
			C	E	H	C	D	H	C	E	H	
Max Rated Voltage	-	Vac	480	240	120	480	480	240	480	480	240	
		Vdc	640	320	160	640	640	320	640	640	320	
Continuous (Stall) Torque ⑤	T <sub>cs</sub>	N-m	1.10	1.15	1.18	1.95	1.99	2.05	2.66	2.74	2.83	
		lb-in	9.8	10.2	10.5	17.3	17.7	18.2	23.6	24.3	25.1	
Continuous (Stall) Current	I <sub>cs</sub>	Arms	1.37	2.99	5.85	1.44	2.23	5.50	1.47	2.58	5.62	
		Adc	1.68	3.66	7.17	1.76	2.73	6.74	1.80	3.16	6.88	
Peak Torque	T <sub>p</sub>	N-m	3.83	3.95	4.01	6.87	7.00	7.21	9.71	9.91	10.2	
		lb-in	33.9	35.0	35.5	60.8	62.0	63.9	86.0	87.8	90.3	
Peak Current	I <sub>p</sub>	Arms	5.50	12.0	23.4	5.70	8.90	22.0	5.90	10.3	22.5	
		Adc	6.74	14.7	28.7	6.98	10.9	27.0	7.23	12.6	27.6	
Torque Constant at 140°C	K <sub>t</sub>	N-m / Arms	0.85	0.41	0.21	1.40	0.92	0.39	1.86	1.10	0.52	
		lb-in / Arms	7.5	3.6	1.9	12.4	8.1	3.5	16.5	9.7	4.6	
BEMF Constant ②	K <sub>e</sub>	V <sub>rms</sub> / Krpm	54.5	26.1	13.7	89.8	59.0	24.8	120	70.6	33.4	
Resistance ②	R <sub>m</sub>	Ohms	21.4	4.74	1.29	23.8	10.30	1.69	26.6	9.01	1.96	
Inductance ②	mH	mH	38	8.6	2.4	47	20	3.6	54	19	4.1	
75 VDC	Rated Speed ① ③	Nrtd	-	750	2000	-	-	1200	-	-	800	
		Rated Torque ① ③ ⑤	T <sub>rtd</sub>	N-m	-	1.14	1.15	-	-	2.01	-	2.77
				lb-in	-	10.1	10.2	-	-	17.8	-	24.6
Rated Power ① ③	P <sub>rtd</sub>	kW	-	0.090	0.24	-	-	0.25	-	0.23		
		Hp	-	0.12	0.32	-	-	0.34	-	0.31		
120 Vac (160 Vdc)	Rated Speed ① ③	Nrtd	-	2500	6000	-	1000	3000	-	-	2500	
		Rated Torque ① ③ ⑤	T <sub>rtd</sub>	N-m	-	1.12	0.923	-	1.95	1.91	-	2.61
				lb-in	-	9.95	8.17	-	17.3	16.9	-	23.1
Rated Power ① ③	P <sub>rtd</sub>	kW	-	0.29	0.58	-	0.20	0.60	-	0.68		
		Hp	-	0.39	0.78	-	0.27	0.81	-	0.92		
240 Vac (320 Vdc)	Rated Speed ① ③	Nrtd	2500	6000	-	1500	2500	7000	1000	2000	5500	
		Rated Torque ① ③ ⑤	T <sub>rtd</sub>	N-m	1.07	0.903	-	1.90	1.88	1.40	2.59	2.27
				lb-in	9.50	8.00	-	16.9	16.7	12.4	23.0	22.8
Rated Power ① ③	P <sub>rtd</sub>	kW	0.28	0.57	-	0.30	0.49	1.03	0.27	0.54		
		Hp	0.38	0.76	-	0.40	0.66	1.38	0.36	0.72		
400 Vac (560 Vdc)	Rated Speed ① ③	Nrtd	5000	-	-	3000	5500	-	2000	4500	-	
		Rated Torque ① ③ ⑤	T <sub>rtd</sub>	N-m	0.953	-	-	1.81	1.60	-	2.49	2.29
				lb-in	8.44	-	-	16.1	14.2	-	22.1	20.3
Rated Power ① ③	P <sub>rtd</sub>	kW	0.50	-	-	0.57	0.92	-	0.52	1.08		
		Hp	0.67	-	-	0.76	1.24	-	0.70	1.45		
480 Vac (640 Vdc)	Rated Speed ① ③	Nrtd	6000	-	-	3500	6000	-	2500	5000	-	
		Rated Torque ① ③ ⑤	T <sub>rtd</sub>	N-m	0.863	-	-	1.78	1.53	-	2.45	2.22
				lb-in	7.64	-	-	15.8	13.6	-	21.7	19.7
Rated Power ① ③	P <sub>rtd</sub>	kW	0.54	-	-	0.65	0.96	-	0.64	1.16		
		Hp	0.73	-	-	0.88	1.29	-	0.86	1.56		
Inertia (includes resolver)	J <sub>m</sub>	kg-cm <sup>2</sup>	-	0.33	-	-	0.59	-	-	0.85		
		lb-in-s <sup>2</sup>	-	2.90E-04	-	-	5.20E-04	-	-	7.50E-04		
Brake Inertia (additional)	J <sub>m</sub>	kg-cm <sup>2</sup>	-	0.012	-	-	0.012	-	-	0.012		
		lb-in-s <sup>2</sup>	-	1.10E-05	-	-	1.10E-05	-	-	1.10E-05		
Static Friction (includes shaft seal)	T <sub>f</sub>	N-m	-	0.061	-	-	0.067	-	-	0.073		
		lb-in	-	0.540	-	-	0.593	-	-	0.646		
Viscous Damping	K <sub>dv</sub>	N-m / krpm	-	0.002	-	-	0.003	-	-	0.004		
		lb-in / krpm	-	0.02	-	-	0.03	-	-	0.04		
Weight ⑥	W	kg	-	1.64	-	-	2.32	-	-	3.00		
		lb	-	3.60	-	-	5.10	-	-	6.60		
Thermal Time Constant	TCT	minutes	-	14	-	-	17	-	-	20		
Thermal Resistance	R <sub>th</sub>	°C / Watt	-	1.11	-	-	0.92	-	-	0.78		
Heat Sink Size	Aluminum	inch	-	10" x 10" x 1/4"	-	-	10" x 10" x 1/4"	-	-	10" x 10" x 1/4"		
Poles Pair			-	4	-	-	4	-	-	4		
Maximum Mechanical Speed ④	N <sub>max</sub>	rpm	-	8,000	-	-	8,000	-	-	8,000		

Notes:

① Motor Performance based on ΔT = 100°C in a 40°C ambient (winding temp = 140°C) with listed Heat Sink.

② Motor Parameters BEMF, Resistance, and Inductance measured at 25°C.

③ All data referenced to sinusoidal commutation.

④ Speed may be limited by V<sub>bus</sub>.

⑤ Brake option reduces continuous torque by: EKM31 = 0.0 Nm, EKM32 = 0.05 Nm, EKM33 = 0.1 Nm,

⑥ Motor weight does not include brake option. EKM3 brake adds 0.35 kg (0.77 lb.).

## EKM3x Frame Dimensional Drawings

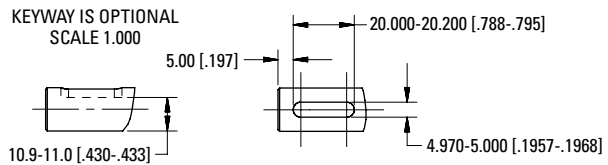
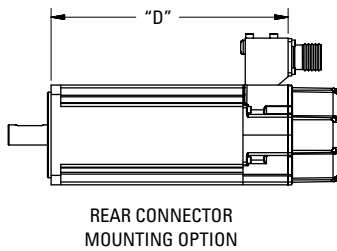
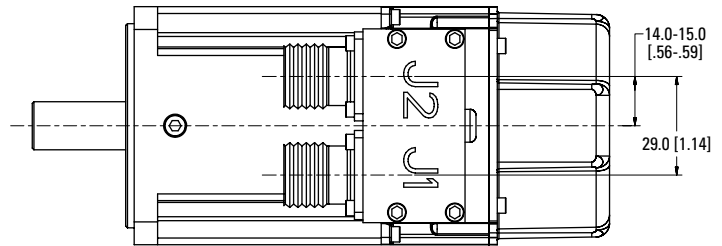
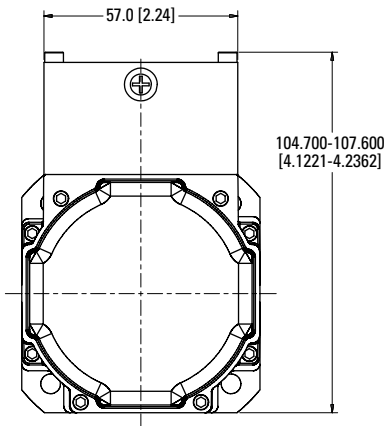
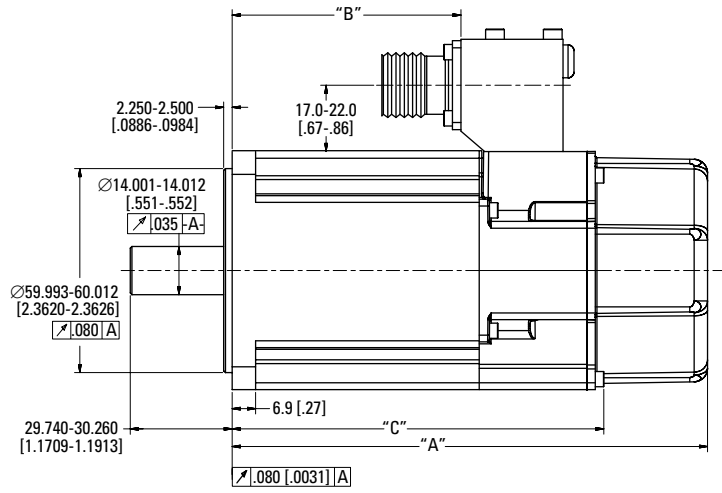
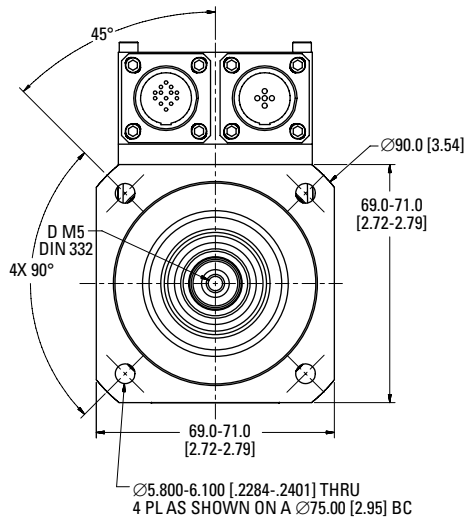

Model	"A"	"B"	"C"	"D"
EKM31	138.74 - 140.74	65.74 - 88.74	108.24 - 110.24	102.74 - 105.74
EKM32	169.74 - 171.74	96.74 - 99.74	139.24 - 141.24	133.74 - 136.74
EKM33	200.74 - 202.74	127.74 - 130.74	170.24 - 172.24	164.74 - 167.74

Dimensions are in mm [inches].  
Product designed in metric.  
English conversions provided for reference only.

\*Complete EKM series model nomenclature can be found on page 9.

# EKM Servo Motor Specifications

## EKM4x Performance Data – Up to 480 Vac (640 Vdc bus) voltage

Performance & Parameters	Symbol	Units	EKM41			EKM42				EKM43			EKM44				
			Windings			Windings				Windings			Windings				
			C	E	H	C	E	G	J	E	G	K	E	G	J		
Max Rated Voltage	-	Vac	480	480	240	480	480	480	240	480	480	240	480	480	480		
		Vdc	640	640	320	640	640	640	320	640	640	320	640	640	640		
Continuous (Stall) Torque ⑤	Tcs	N-m	1.88	1.95	1.99	3.28	3.35	3.46	3.49	4.63	4.73	4.83	5.69	5.81	5.93		
		lb-in	16.6	17.3	17.6	29.0	29.7	30.6	30.9	41.0	41.9	42.8	50.4	51.4	52.5		
Continuous (Stall) Current	Ics	Arms	1.46	2.85	5.60	1.40	2.74	4.80	8.40	2.76	4.87	9.60	2.90	5.00	8.80		
		Adc	1.79	3.49	6.86	1.72	3.36	5.88	10.3	3.38	5.97	11.8	3.55	6.13	10.8		
Peak Torque	Tp	N-m	6.05	6.21	6.29	11.0	11.2	11.4	11.5	15.8	16.0	16.2	19.8	20.1	20.3		
		lb-in	53.6	55.0	55.7	97.4	99.2	101	102	140	142	143	175	178	180		
Peak Current	Ip	Arms	5.80	11.4	22.4	5.61	11.0	19.2	33.7	11.0	19.5	38.3	11.4	20.0	35.2		
		Adc	7.11	14.0	27.4	6.87	13.5	23.5	41.3	13.5	23.9	46.9	13.97	24.5	43.1		
Torque Constant at 140°C	Kt	N-m / Arms	1.34	0.71	0.37	2.40	1.26	0.74	0.43	1.72	0.99	0.52	2.04	1.19	0.69		
		lb-in / Arms	11.9	6.29	3.28	21.4	11.2	6.55	3.81	15.2	8.77	4.61	18.1	10.5	6.11		
BEMF Constant ②	Ke	Vrms / Krpm	86.3	45.6	23.7	154	80.9	47.5	27.5	111	63.9	33.2	132	76.6	44.2		
Resistance ②	Rm	Ohms	21.3	6.02	1.56	27.5	7.78	2.51	0.800	8.61	2.81	0.740	8.04	2.80	0.940		
Inductance ②	mH	mH	66	18	5.0	97	27	9.2	3.1	33	11	2.9	34	12	3.8		
75 VDC	Rated Speed ① ③	Nrtd	rpm	-	-	1000	-	-	-	-	-	-	-	-	-		
		Rated Torque ① ③ ⑤	Trtd	N-m	-	-	1.92	-	-	-	-	-	-	-	-		
				lb-in	-	-	17.0	-	-	-	-	-	-	-	-		
Rated Power ① ③	Prtd	kW	-	-	0.20	-	-	-	-	-	-	-	-	-			
		Hp	-	-	0.27	-	-	-	-	-	-	-	-	-			
120 Vac (160 Vdc)	Rated Speed ① ③	Nrtd	rpm	-	1200	3000	-	-	-	3000	-	-	2500	-	-		
		Rated Torque ① ③ ⑤	Trtd	N-m	-	1.81	1.75	-	-	-	2.96	-	-	4.01	-	-	
				lb-in	-	16.0	15.5	-	-	-	26.2	-	-	35.5	-	-	
Rated Power ① ③	Prtd	kW	-	0.23	0.55	-	-	-	0.93	-	-	1.05	-	-			
		Hp	-	0.30	0.74	-	-	-	1.25	-	-	1.41	-	-			
240 Vac (320 Vdc)	Rated Speed ① ③	Nrtd	rpm	1200	3000	6000	-	1800	3500	6000	1500	2500	6000	1200	2000	4000	
		Rated Torque ① ③ ⑤	Trtd	N-m	1.81	1.75	1.55	-	3.05	2.83	2.31	4.17	3.93	2.55	5.15	4.83	3.77
				lb-in	16.0	15.5	13.7	-	27.0	25.1	20.4	36.9	34.8	22.6	45.6	42.8	33.4
Rated Power ① ③	Prtd	kW	0.23	0.55	0.97	-	0.57	1.04	1.45	0.65	1.03	1.60	0.65	1.01	1.58		
		Hp	0.30	0.74	1.30	-	0.77	1.39	1.94	0.88	1.38	2.15	0.87	1.36	2.12		
400 Vac (560 Vdc)	Rated Speed ① ③	Nrtd	rpm	3000	6000	-	1500	3500	6000	-	2500	5000	-	2000	4000	6000	
		Rated Torque ① ③ ⑤	Trtd	N-m	1.70	1.51	-	3.03	2.74	2.28	-	3.85	2.94	-	4.73	3.69	2.68
				lb-in	15.0	13.4	-	26.8	24.3	20.2	-	34.1	26.0	-	41.9	32.7	23.7
Rated Power ① ③	Prtd	kW	0.53	0.95	-	0.48	1.00	1.43	-	1.01	1.54	-	0.99	1.55	1.68		
		Hp	0.72	1.27	-	0.64	1.35	1.92	-	1.35	2.06	-	1.33	2.07	2.26		
480 Vac (640 Vdc)	Rated Speed ① ③	Nrtd	rpm	3500	6000	-	2000	4000	6000	-	3000	6000	-	2500	5000	6000	
		Rated Torque ① ③ ⑤	Trtd	N-m	1.67	1.51	-	2.95	2.65	2.28	-	3.69	2.50	-	4.49	3.12	2.68
				lb-in	14.8	13.4	-	26.1	23.5	20.2	-	32.7	22.1	-	39.8	27.6	23.7
Rated Power ① ③	Prtd	kW	0.61	0.95	-	0.62	1.11	1.43	-	1.16	1.57	-	1.18	1.63	1.68		
		Hp	0.82	1.27	-	0.83	1.49	1.92	-	1.55	2.10	-	1.58	2.19	2.26		
Inertia (includes resolver)	Jm	kg-cm <sup>2</sup>	0.81			1.5				2.1			2.7				
		lb-in-s <sup>2</sup>	7.20E-04			1.30E-03				1.80E-03			2.40E-03				
Brake Inertia (additional)	Jm	kg-cm <sup>2</sup>	0.068			0.068				0.068			0.068				
		lb-in-s <sup>2</sup>	6.00E-05			6.00E-05				6.00E-05			6.00E-05				
Static Friction (includes shaft seal)	Tf	N-m	0.085			0.097				0.109			0.121				
		lb-in	0.753			0.859				0.965			1.07				
Viscous Damping	Kdv	N-m / krpm	0.009			0.013				0.017			0.021				
		lb-in / krpm	0.08			0.12				0.15			0.19				
Weight ⑥	W	Kg	2.55			3.50				4.45			0.54				
		lb	5.60			7.70				9.80			11.9				
Thermal Time Constant	TCT	minutes	13			17				20			24				
Thermal Resistance	Rth	°C / Watt	0.97			0.80				0.70			0.65				
Heat Sink Size	Aluminum	inch	10" x 10" x 1/4"			10" x 10" x 1/4"				10" x 10" x 1/4"			10" x 10" x 1/4"				
Poles Pair			5			5				5			5				
Maximum Mechanical Speed ④	Nmax	rpm	6,000			6,000				6,000			6,000				

Notes:

① Motor Performance based on  $\Delta T = 100^\circ\text{C}$  in a  $40^\circ\text{C}$  ambient (winding temp =  $140^\circ\text{C}$ ) with listed Heat Sink.

② Motor Parameters BEMF, Resistance, and Inductance measured at  $25^\circ\text{C}$ .

③ All data referenced to sinusoidal commutation.

④ Speed may be limited by Vbus.

⑤ Brake option reduces continuous torque by 0.012 Nm

⑥ Motor weight does not include brake option. EKM4 brake adds 0.63 kg (1.39 lb.).

### EKM4x Frame Dimensional Drawings

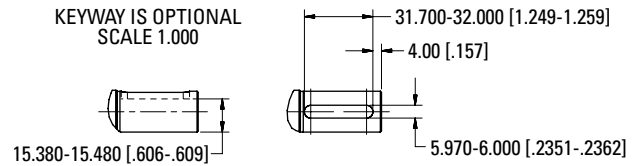
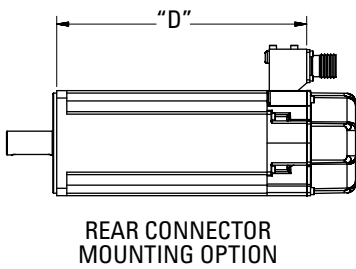
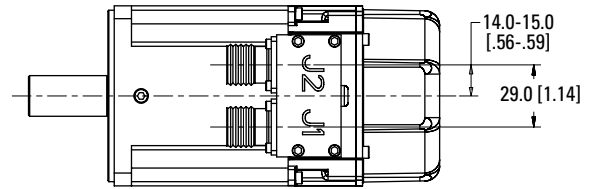
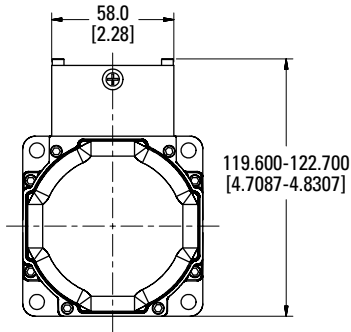
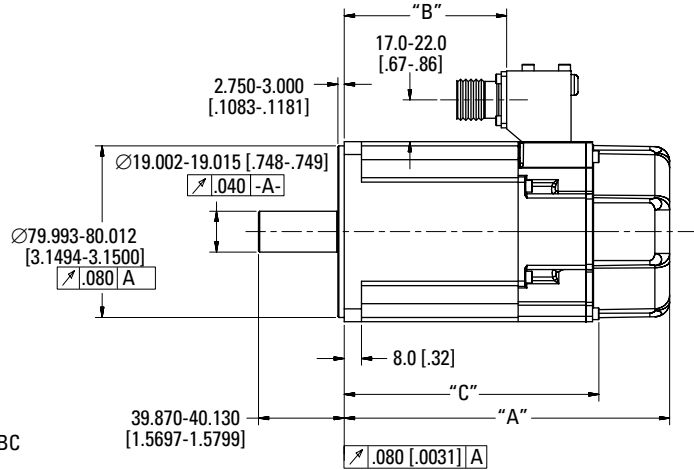
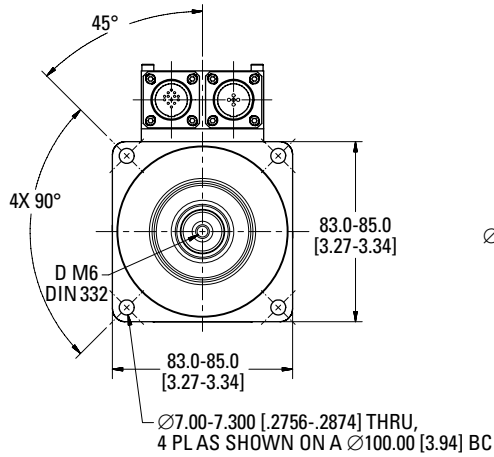

Model	"A"	"B"	"C"	"D"
EKM41	150.75 - 152.75	74.25 - 77.25	117.25 - 119.25	111.25 - 114.25
EKM42	179.75 - 181.75	103.25 - 106.25	146.25 - 148.25	140.25 - 143.25
EKM43	208.75 - 210.75	132.25 - 135.25	175.25 - 177.25	169.25 - 172.25
EKM44	237.75 - 239.75	161.25 - 164.25	204.25 - 206.25	198.25 - 201.25

Dimensions are in mm [inches].  
 Product designed in metric.  
 English conversions provided for reference only.

\*Complete EKM series model nomenclature can be found on page 9.

# EKM Servo Motor Specifications

## EKM5x Performance Data – Up to 480 Vac (640 Vdc bus) voltage

Performance & Parameters	Symbol	Units	EKM51				EKM52				EKM53				EKM54			
			Windings			Windings				Windings				Windings				
			E	G	K	E	G	K	M	G	K	M	P	G	K	L	N	
Max Rated Voltage	-	Vac	480	480	240	480	480	480	240	480	480	240	240	480	480	400	240	
		Vdc	640	640	320	640	640	640	320	640	640	320	320	640	640	560	320	
Continuous (Stall) Torque ⑤	Tcs	N-m	4.57	4.62	4.77	8.21	8.30	8.47	8.47	11.3	11.5	11.3	11.3	14.2	14.3	14.0	14.0	
		lb-in	40.5	40.9	42.2	72.7	73.5	75.0	75.0	100	102	100	100	125	126	124	124	
Continuous (Stall) Current	Ics	Arms	2.75	4.84	9.4	2.99	4.72	9.30	13.1	4.77	9.40	13.4	19.1	5.00	9.7	12.5	17.8	
		Adc	3.37	5.93	11.5	3.66	5.8	11.4	16.0	5.8	11.5	16.4	23.4	6.13	11.9	15.3	21.8	
Peak Torque	Tp	N-m	11.5	11.6	11.9	21.2	21.4	21.8	21.8	29.6	30.0	29.7	29.7	37.7	38.3	37.4	37.5	
		lb-in	102	102	105	187	189	193	193	262	266	263	263	334	339	331	332	
Peak Current	Ip	Arms	8.24	14.5	28.3	9.00	14.2	27.8	39.4	14.3	28.1	40.3	57.4	14.9	29.2	37.5	53.4	
		Adc	10.1	17.8	34.7	11.0	17.4	34.1	48.3	17.5	34.4	49.4	70.3	18.3	35.8	45.9	65.4	
Torque Constant at 140°C	Kt	N-m / Arms	1.72	0.99	0.52	2.79	1.79	0.93	0.66	2.39	1.24	0.85	0.60	2.88	1.50	1.13	0.80	
		lb-in / Arms	15.2	8.77	4.61	24.7	15.9	8.24	5.84	21.2	11.0	7.53	5.31	25.5	13.3	10.0	7.08	
BEMF Constant ②	Ke	Vrms / Krpm	110	63.6	33.5	179	115	60.1	42.4	154	79.8	54.7	38.4	185	96.6	72.9	51.3	
Resistance ②	Rm	Ohms	8.98	2.87	0.75	8.96	3.70	0.96	0.49	3.97	1.06	0.51	0.28	4.08	1.08	0.65	0.33	
Inductance ②	mH	mH	37	12	3.4	45	19	5.0	2.5	21	5.7	2.7	1.3	23	6.2	3.5	1.8	
75 VDC Rated Speed ① ③	Nrtd	rpm	-	-	-	-	-	-	-	-	-	-	-	-	-	-	-	
		N-m	-	-	-	-	-	-	-	-	-	-	-	-	-	-	-	
Rated Torque ① ③ ⑤	Trtd	lb-in	-	-	-	-	-	-	-	-	-	-	-	-	-	-	-	
		kW	-	-	-	-	-	-	-	-	-	-	-	-	-	-	-	
Rated Power ① ③	Prtd	Hp	-	-	-	-	-	-	-	-	-	-	-	-	-	-	-	
		rpm	-	-	2500	-	-	-	-	-	-	-	-	-	-	-	-	-
120 Vac (160 Vdc) Rated Speed ① ③	Nrtd	rpm	-	-	2500	-	-	-	-	-	-	-	-	-	-	-	-	
		N-m	-	-	4.02	-	-	-	-	-	-	-	-	-	-	-	-	
Rated Torque ① ③ ⑤	Trtd	lb-in	-	-	35.6	-	-	-	-	-	-	-	-	-	-	-	-	
		kW	-	-	1.05	-	-	-	-	-	-	-	-	-	-	-	-	
Rated Power ① ③	Prtd	Hp	-	-	1.41	-	-	-	-	-	-	-	-	-	-	-	-	
		rpm	1200	2500	5500	-	1500	3000	4500	1000	2000	3000	5000	-	1800	2500	3500	
240 Vac (320 Vdc) Rated Speed ① ③	Nrtd	rpm	1200	2500	5500	-	1500	3000	4500	1000	2000	3000	5000	-	1800	2500	3500	
		N-m	4.28	3.89	2.22	-	7.56	6.67	5.07	10.6	9.97	8.59	5.75	-	12.6	11.4	9.72	
Rated Torque ① ③ ⑤	Trtd	lb-in	37.9	34.4	19.7	-	67.0	59.1	44.9	93.6	88.3	76.1	50.9	-	111	100.7	86.1	
		kW	0.54	1.02	1.28	-	1.19	2.10	2.39	1.11	2.09	2.70	3.01	-	2.37	2.98	3.56	
Rated Power ① ③	Prtd	Hp	0.72	1.37	1.71	-	1.59	2.81	3.20	1.48	2.80	3.62	4.04	-	3.18	3.99	4.78	
		rpm	2500	5000	-	1500	2500	5500	-	2000	4000	-	-	-	1500	3500	4500	-
400 Vac (560 Vdc) Rated Speed ① ③	Nrtd	rpm	2500	5000	-	1500	2500	5500	-	2000	4000	-	-	-	1500	3500	4500	-
		N-m	3.85	2.49	-	7.48	6.93	3.77	-	9.72	7.52	-	-	-	12.8	9.92	8.00	-
Rated Torque ① ③ ⑤	Trtd	lb-in	34.1	22.1	-	66.2	61.4	33.4	-	86.1	66.6	-	-	-	113	87.9	70.8	-
		kW	1.01	1.30	-	1.17	1.81	2.17	-	2.04	3.15	-	-	-	2.01	3.64	3.77	-
Rated Power ① ③	Prtd	Hp	1.35	1.75	-	1.58	2.43	2.91	-	2.73	4.22	-	-	-	2.69	4.87	5.05	-
		rpm	3000	6000	-	2000	3000	6000	-	2400	4500	-	-	-	2000	4000	-	-
480 Vac (640 Vdc) Rated Speed ① ③	Nrtd	rpm	3000	6000	-	2000	3000	6000	-	2400	4500	-	-	-	2000	4000	-	-
		N-m	3.67	1.81	-	7.15	6.53	3.12	-	9.37	6.72	-	-	-	12.2	9.12	-	-
Rated Torque ① ③ ⑤	Trtd	lb-in	32.5	16.0	-	63.3	57.8	27.6	-	83.0	59.5	-	-	-	108	80.8	-	-
		kW	1.15	1.14	-	1.50	2.05	1.96	-	2.35	3.17	-	-	-	2.55	3.82	-	-
Rated Power ① ③	Prtd	Hp	1.55	1.52	-	2.01	2.75	2.63	-	3.16	4.24	-	-	-	3.42	5.12	-	-
		kg-cm <sup>2</sup>		3.4			6.2			9.1					12			
Inertia (includes resolver)	Jm	lb-in-s <sup>2</sup>		3.00E-03		5.50E-03				8.10E-03				1.10E-02				
		kg-cm <sup>2</sup>		0.17		0.17				0.17				0.17				
Brake Inertia (additional)	Jm	lb-in-s <sup>2</sup>		1.50E-04		1.50E-04				1.50E-04				1.50E-04				
		kg-cm <sup>2</sup>		0.152		0.170				0.188				0.207				
Static Friction (includes shaft seal)	Tf	lb-in		1.35		1.51				1.66				1.83				
		N-m / krpm		0.033		0.042				0.052				0.061				
Viscous Damping	Kdv	lb-in / krpm		0.29		0.37				0.46				0.54				
		Kg		4.50		6.10				7.68				9.27				
Weight ⑥	W	lb		9.90		13.4				16.9				20.4				
		minutes		20		24				28				31				
Thermal Time Constant	TCT	minutes		20		24				28				31				
Thermal Resistance	Rth	°C / Watt		0.68		0.56				0.50				0.45				
Heat Sink Size	Aluminum	inch	12" x 12" x 1/2"				12 x 12" x 1/2"				12" x 12" x 1/2"				12" x 12" x 1/2"			
Poles Pair			5				5				5				5			
Maximum Mechanical Speed ④	Nmax	rpm	6,000				6,000				6,000				6,000			

Notes:

① Motor Performance based on  $\Delta T = 100^\circ\text{C}$  in a  $40^\circ\text{C}$  ambient (winding temp =  $140^\circ\text{C}$ ) with listed Heat Sink.

② Motor Parameters BEMF, Resistance, and Inductance measured at  $25^\circ\text{C}$ .

③ All data referenced to sinusoidal commutation.

④ Speed may be limited by Vbus.

⑤ Brake option reduces continuous torque by: EKM51 = 0.15 Nm, EKM52 = 0.26 Nm, EKM53 = 0.35 Nm, EKM54 = 0.43 Nm

⑥ Motor weight does not include brake option. EKM5 brake adds 1.1 kg (2.42 lb).



### EKM5x Frame Dimensional Drawings

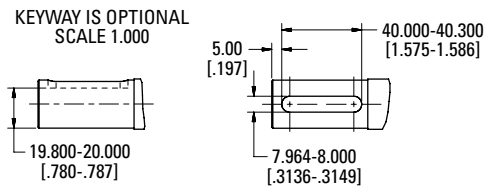
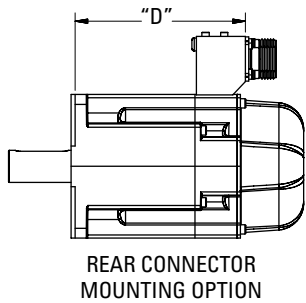
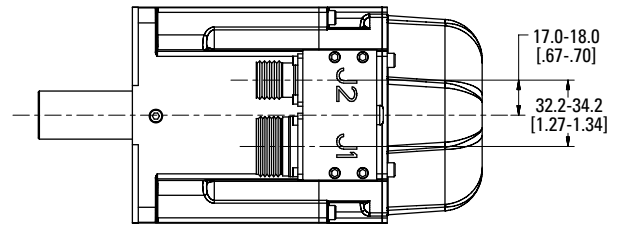
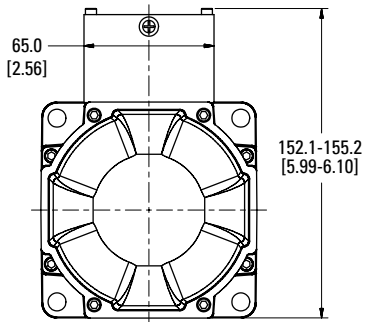
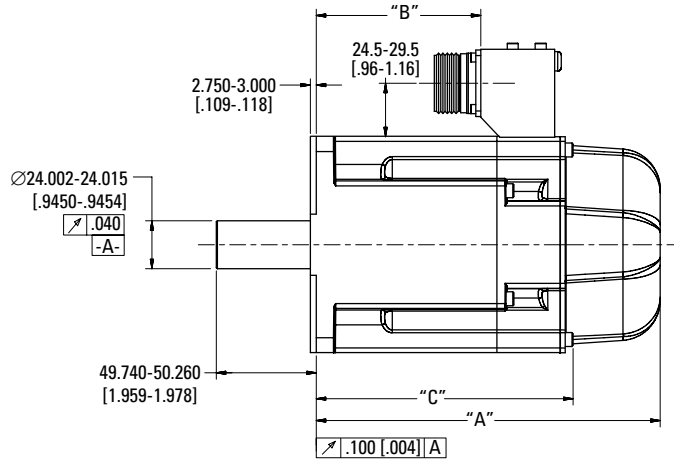
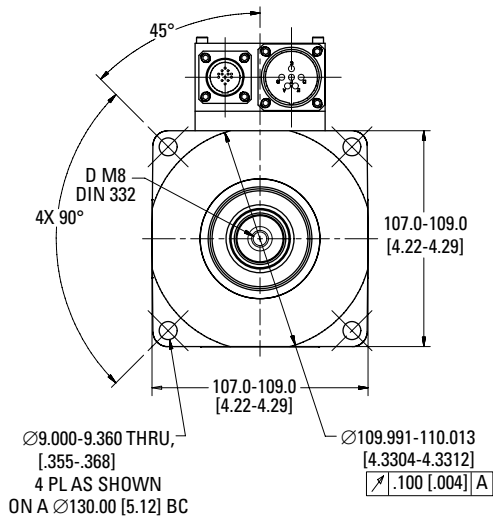

Model	"A"	"B"	"C"	"D"
EKM51	170.95 - 172.95	80.75 - 83.75	125.95 - 127.95	126.75 - 129.75
EKM52	201.95 - 203.95	111.75 - 114.75	156.95 - 158.95	157.75 - 160.75
EKM53	232.95 - 234.95	142.75 - 145.75	187.95 - 189.95	188.75 - 191.75
EKM54	263.95 - 265.95	173.75 - 176.75	218.95 - 220.95	219.75 - 222.75

Dimensions are in mm [inches].  
Product designed in metric.  
English conversions provided for reference only.

\*Complete EKM series model nomenclature can be found on page 9.



### EKM6x Frame Dimensional Drawings

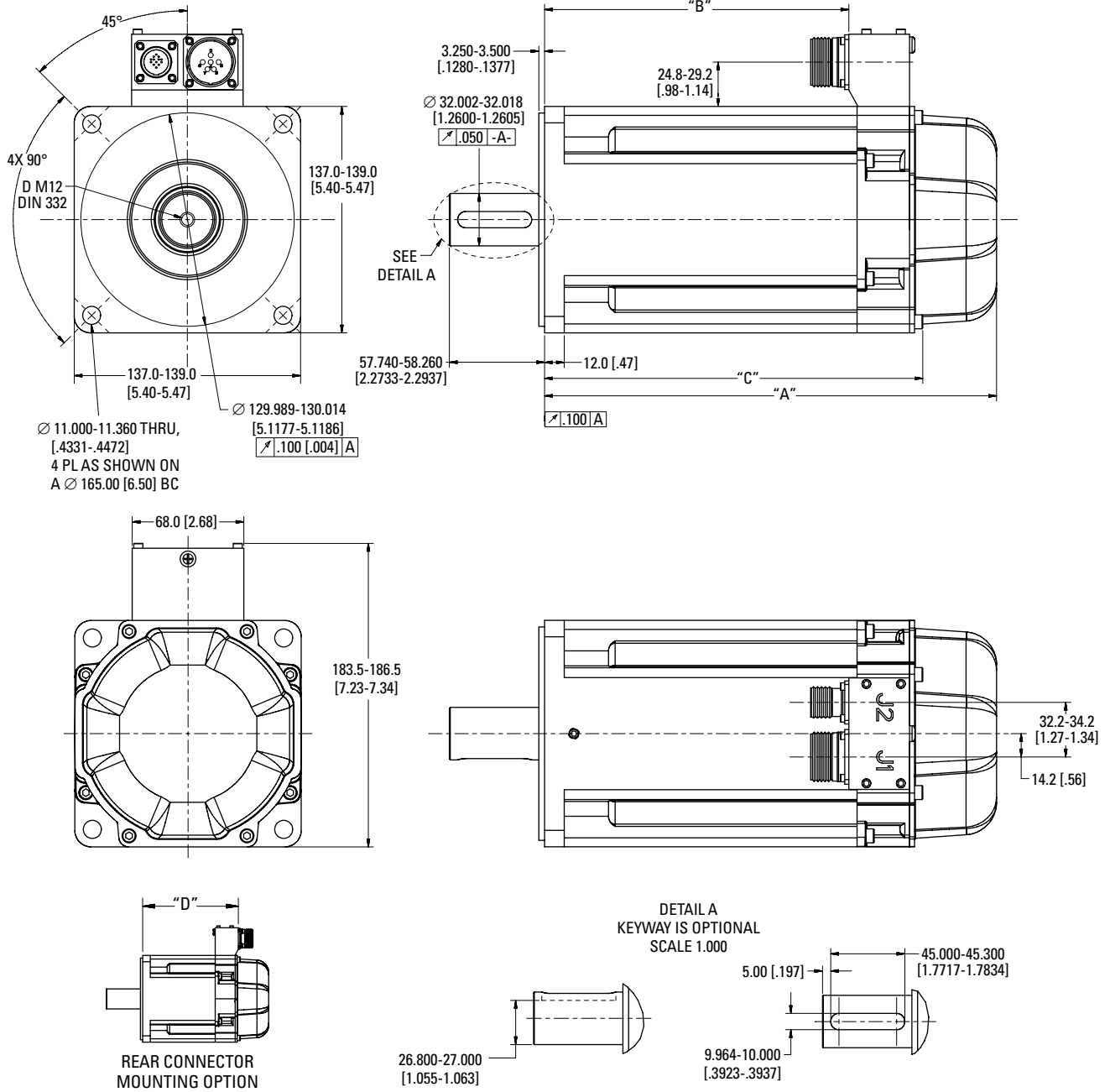

Model	"A"	"B"	"C"	"D"
EKM62	199.55 - 201.55	109.00 - 112.00	154.6 - 156.6	135.7 - 138.8
EKM63	224.55 - 226.55	134.00 - 137.00	179.6 - 181.6	160.7 - 163.8
EKM64	249.55 - 251.55	159.00 - 162.00	204.6 - 206.6	185.7 - 188.8
EKM65	274.55 - 276.55	184.00 - 187.00	229.6 - 231.6	210.7 - 213.8

Dimensions are in mm [inches].  
 Product designed in metric.  
 English conversions provided for reference only.

\*Complete EKM series model nomenclature can be found on page 9.

# EKM Servo Motor Specifications

## EKM7x Performance Data – Up to 480 Vac (640 Vdc bus) voltage

Performance & Parameters	Symbol	Units	EKM72			EKM73		EKM74	
			Windings			Windings		Windings	
			K	M	P	M	P	L	P
Max Rated Voltage	-	Vac	480	480	480	480	480	480	480
		Vdc	640	640	640	640	640	640	640
Continuous (Stall) Torque ⑤	Tcs	N-m	29.5	29.8	29.2	41.8	41.4	52.8	52.3
		lb-in	261	263	258	370	366	467	463
Continuous (Stall) Current	Ics	Arms	9.30	13.0	18.7	13.6	19.5	12.9	18.5
		Adc	11.4	15.9	22.9	16.7	23.9	15.8	22.7
Peak Torque	Tp	N-m	79.0	79.5	78.3	113	111	143	142
		lb-in	700	704	693	1001	983	1266	1258
Peak Current	Ip	Arms	27.8	38.9	56.1	40.8	58.6	38.7	55.5
		Adc	34.1	47.7	68.7	50.0	71.8	47.4	68.0
Torque Constant at 140°C	Kt	N-m / Arms	3.23	2.33	1.58	3.10	2.13	4.14	2.84
		lb-in / Arms	28.6	20.6	14.0	27.5	18.9	36.7	25.2
BEMF Constant ②	Ke	Vrms / Krpm	208	150	102	200	137	266	183
Resistance ②	Rm	Ohms	1.36	0.69	0.35	0.76	0.38	0.93	0.47
Inductance ②	mH	mH	21	11	5.0	12	5.9	16	7.7
75 VDC	Rated Speed ① ③	Nrtd	-	-	-	-	-	-	-
		Trtd	-	-	-	-	-	-	-
120 Vac (160 Vdc)	Rated Torque ① ③ ⑤	N-m	-	-	-	-	-	-	-
		lb-in	-	-	-	-	-	-	-
240 Vac (320 Vdc)	Rated Power ① ③	kW	-	-	-	-	-	-	-
		Hp	-	-	-	-	-	-	-
400 Vac (560 Vdc)	Rated Speed ① ③	Nrtd	-	-	1800	-	1300	-	-
		Trtd	-	-	23.6	-	34.5	-	-
480 Vac (640 Vdc)	Rated Torque ① ③ ⑤	N-m	-	-	209	-	305	-	-
		lb-in	-	-	4.44	-	4.69	-	-
75 VDC	Rated Power ① ③	kW	-	-	5.95	-	6.29	-	-
		Hp	-	-	8.05	-	10.24	-	-
120 Vac (160 Vdc)	Rated Speed ① ③	Nrtd	1500	2000	3000	1500	2400	1200	1800
		Trtd	24.9	23.4	19.9	33.6	28.3	43.3	39.4
240 Vac (320 Vdc)	Rated Torque ① ③ ⑤	N-m	220	207	176	297	250	383	348
		lb-in	3.90	4.89	6.24	5.27	7.10	5.43	7.42
400 Vac (560 Vdc)	Rated Power ① ③	kW	5.23	6.56	8.36	7.06	9.52	7.29	9.94
		Hp	1800	2500	3500	1800	2800	1400	2000
480 Vac (640 Vdc)	Rated Speed ① ③	Nrtd	23.8	21.9	18.0	31.9	26.1	41.3	35.7
		Trtd	210	194	159	282	231	365	316
75 VDC	Rated Power ① ③	kW	4.48	5.72	6.58	6.00	7.64	6.05	7.47
		Hp	6.00	7.67	8.82	8.05	10.24	8.11	10.01
Inertia (includes resolver)	Jm	kg-cm <sup>2</sup>	65			92		120	
		lb-in-s <sup>2</sup>	0.057			0.082		0.110	
Brake Inertia (additional)	Jm	kg-cm <sup>2</sup>	1.64			1.64		1.64	
		lb-in-s <sup>2</sup>	1.46E-03			1.46E-03		1.46E-03	
Static Friction (includes shaft seal)	Tf	N-m	0.41			0.49		0.58	
		lb-in	3.63			4.34		5.14	
Viscous Damping	Kdv	N-m / krpm	0.06			0.13		0.2	
		lb-in / krpm	0.5			1.2		1.8	
Weight ⑥	W	Kg	20.0			27.0		33.9	
		lb	44.0			59.4		74.6	
Thermal Time Constant	TCT	minutes	46			53		60	
Thermal Resistance	Rth	°C / Watt	0.39			0.33		0.30	
Heat Sink Size	Aluminum	inch	18" x 18" x 1/2"			18" x 18" x 1/2"		18" x 18" x 1/2"	
Poles Pair			5			5		5	
Maximum Mechanical Speed ④	Nmax	rpm	6,000			6,000		6,000	

Notes:

① Motor Performance based on  $\Delta T = 100^\circ\text{C}$  in a  $40^\circ\text{C}$  ambient (winding temp =  $140^\circ\text{C}$ ) with listed Heat Sink.

② Motor Parameters BEMF, Resistance, and Inductance measured at  $25^\circ\text{C}$ .

③ All data referenced to sinusoidal commutation.

④ Speed may be limited by Vbus.

⑤ Brake option reduces continuous torque by 1.0 N-m

⑥ Motor weight does not include brake option. EKM7 brake adds 2.9 kg (6.38 lb).

## EKM7x Frame Dimensional Drawings

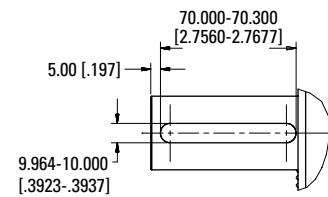
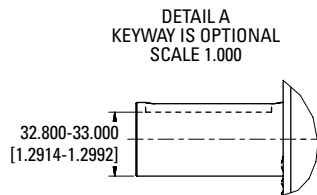
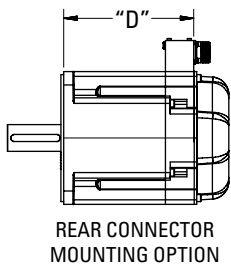
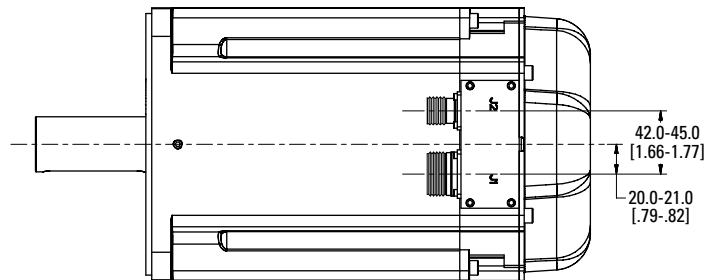
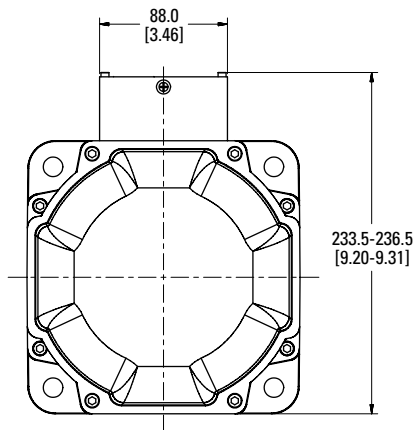
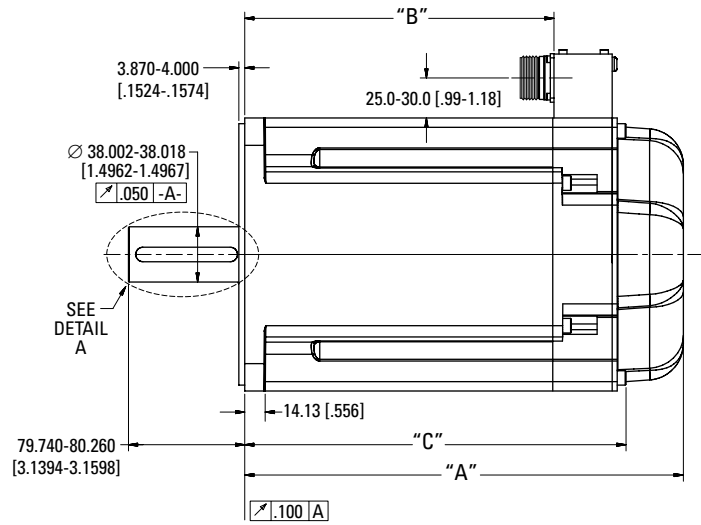
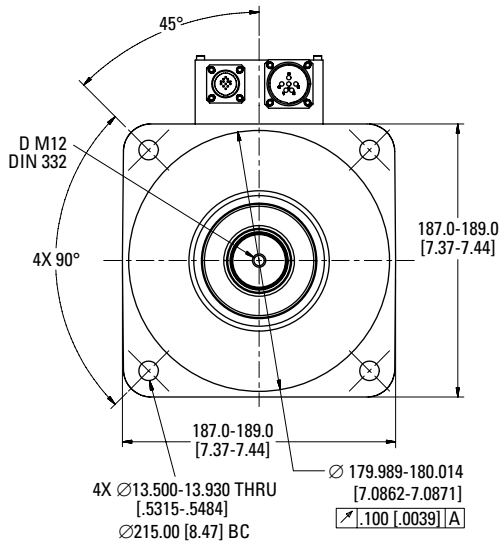

Model	"A"	"B"	"C"	"D"
EKM72	232.92 - 234.92	142.85 - 145.29	193.42 - 195.42	182.85 - 185.29
EKM73	266.92 - 268.92	176.85 - 179.29	227.42 - 229.42	216.85 - 219.29
EKM74	300.92 - 302.92	210.85 - 213.29	261.42 - 263.42	250.85 - 253.29

Dimensions are in mm [inches].  
Product designed in metric.  
English conversions provided for reference only.

\*Complete EKM series model nomenclature can be found on page 9.

# L10 Bearing Fatigue and Shaft Loading

## L10 Bearing Fatigue

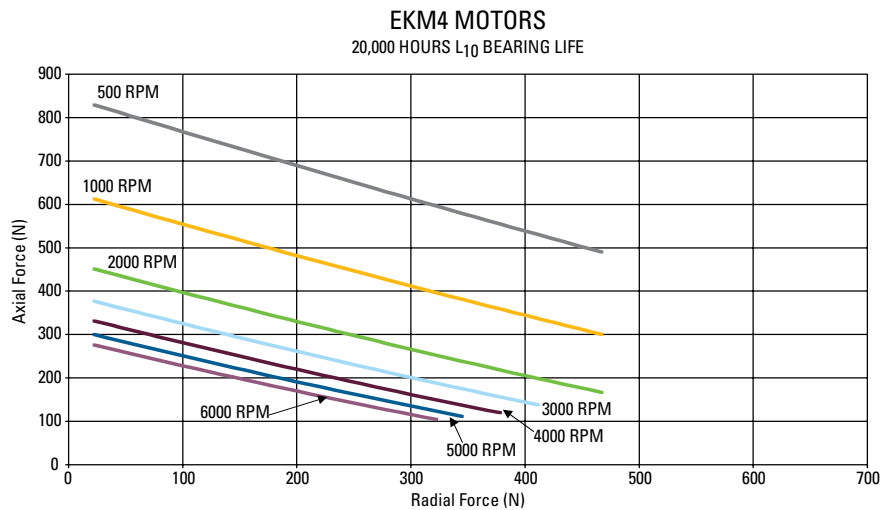
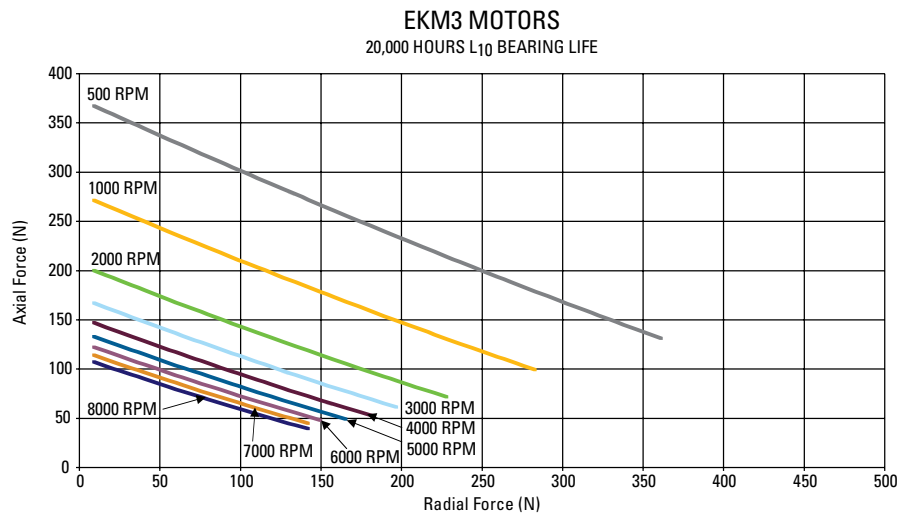
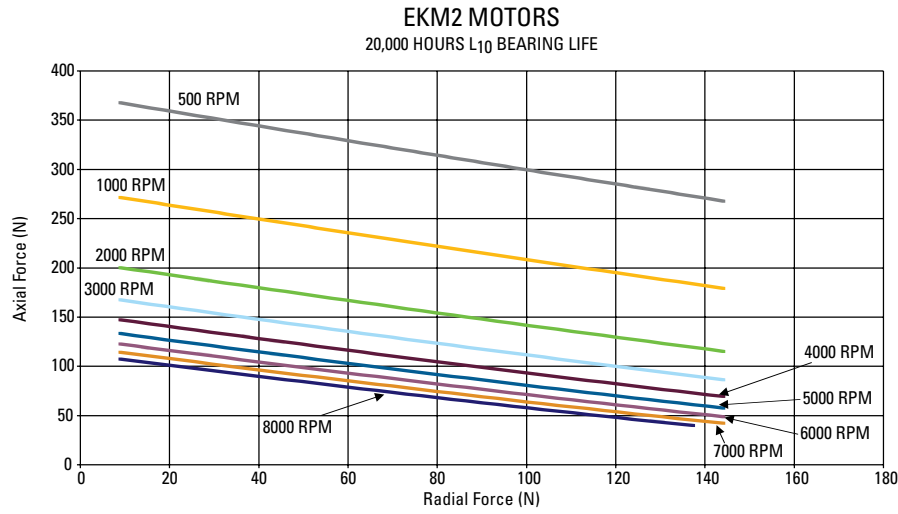

## L10 Bearing Fatigue

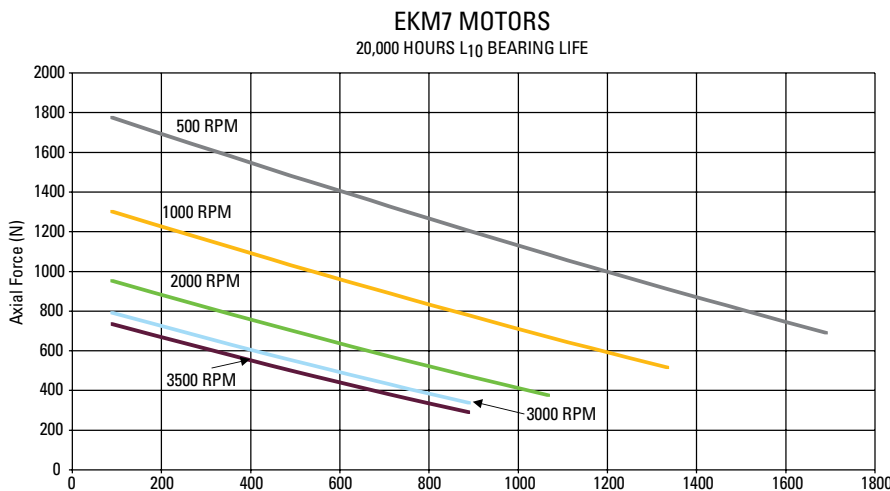
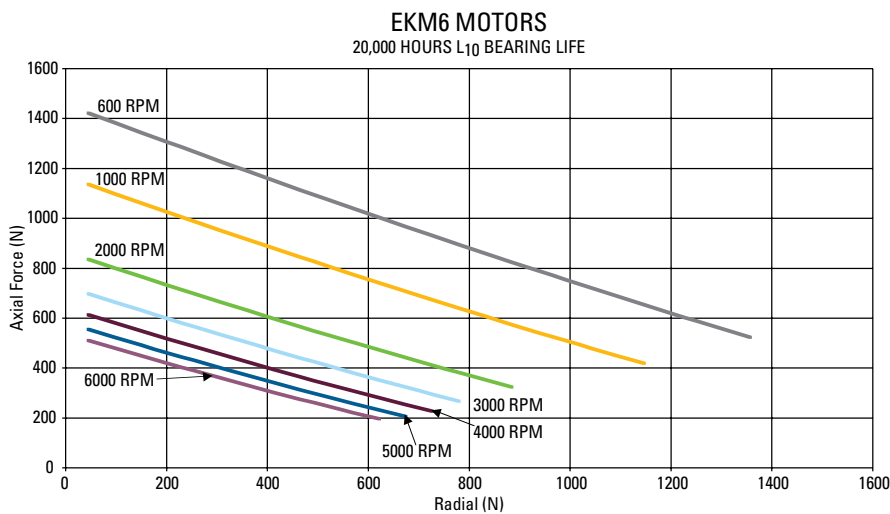
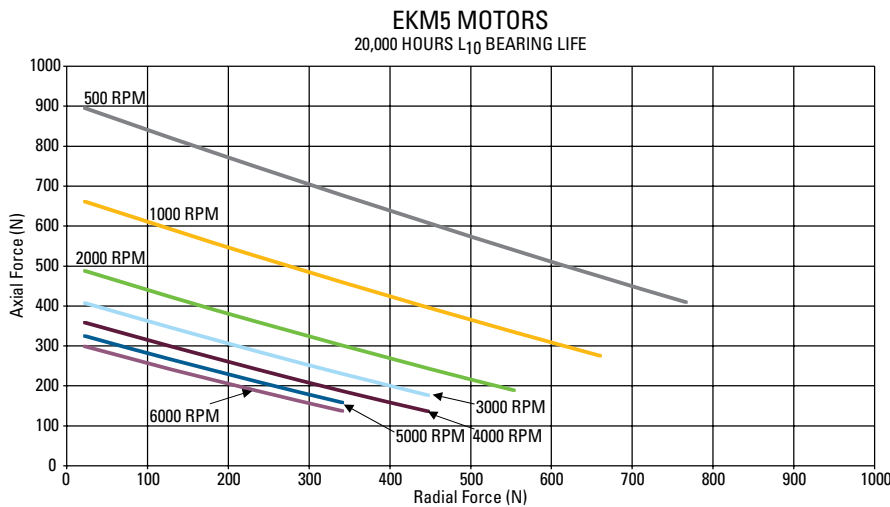

## Shaft Loading

Motor	Max. Radial Force (N)	Max. Axial Force (N)
AKM1	48	200
AKM2	150	600
AKM3	340	600
AKM4	500	1400
AKM5	830	1740
AKM6	1940	2200
AKM7	2300	3000
AKM8	2752	4750

The maximum radial load ratings reflect the following assumptions:

1. Motors are operated with peak torque of the longest member of the frame size.
2. Fully reversed load applied to the end of the smallest diameter standard mounting shaft extension. Excluding AKM4X-EK which is rated at 240 N max. radial force.
3. Infinite life with 99% reliability.
4. Safety factor = 2.

# EKM Motor Resolver Feedback

## Phasing Diagram - All Motors

### General notes:

- When motor is rotated CW (viewed from drive shaft end), these waveforms result: Voltage U, leads V, leads W. Voltage U-W leads Voltage V-W by 60° electrical.
- PTC thermistor (155°C ± 5°C switching temperature) installed. Resistance at 25°C: ≤550 ohms. Switching Resistance: ≥1330 ohms within ±5°C of switch temperature.
- Standard outline drawings showing mounting dimensions and standard winding information are available on our website at [www.kollmorgen.com](http://www.kollmorgen.com) or by calling Kollmorgen Customer Support at 1-540-633-3545, or through email at [support@kollmorgen.com](mailto:support@kollmorgen.com).

### Motor Winding Configuration

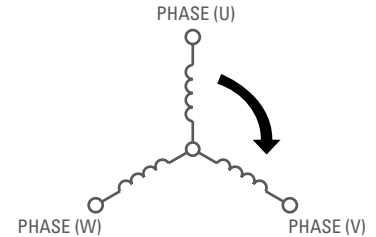

### Resolver (Primary Feedback)

Resolver Data	Units	EKM 2, 3, 4	EKM 5, 6, 7
Type		1 Speed	1 Speed
Input Voltage	V <sub>rms</sub>	7.0	8.0
Frequency	k Hz	10	8.0
Input Current Max.	mA	32	52
Transformation Ratio	10%	0.5	0.5
Null Voltage	mV <sub>rms</sub>	50	30
Max. Error (pk-pk)	MINS.	16	20
Phase Shift	DEG	-9°	-3°
Operating Temperature	°C	-55° to 155°	-55° to 155°
Rotor Inertia Max.	kg cm <sup>2</sup>	0.046	0.497

### Resolver Winding Configuration

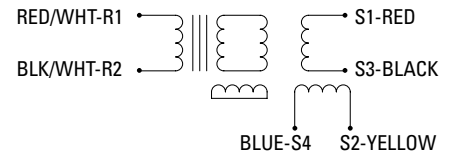

$$E_{R1-R2} = E \sin(\omega T)$$

$$E_{S1-S3} = K E_{R1-R2} \sin \theta$$

$$E_{S2-S4} = K E_{R1-R2} \cos \theta$$

### Resolver Alignment

With positive DC current into phase W and out of phase V (U floats) the resolver is aligned to electrical ±5 counts. ie. Voltage S1-S3 set to null voltage S2-S4 max in phase with reference (R1-R2).

## Failsafe, Holding Brake

The holding brake is designed to provide static holding torque to the motor shaft with the brake coil de-energized. The brake must first be released (coil energized) prior to commanding motor rotation as determined by its drop-out time. The brake is intended for holding or “parking” of a stationary motor. Not intended for dynamic braking. There should be absolutely no motion of the rotor when power is removed from the brake coil.

### EKM Motor Brake Specifications

Motor Family	Minimum Static Torque @120°C		Weight		Power Consumption @24V, 20°C	Current @24V, 20°C	Inertia		Closing Time (engage)	Opening Time (release)	Backlash <sup>2</sup>	
	N-m	lb-in	Kg	lbs			Watts ±7%	ADC			kg-cm <sup>2</sup>	lb-in-sec <sup>2</sup>
EKM2	1.42	12.6	0.27	0.59	8.4	0.35	0.011	0.97E-05	18	20	1.01	0.46
EKM3	2.5	22.1	0.35	0.77	10.1	0.42	0.011	0.97E-05	10	25	1.01	0.46
EKM4	5.3	46.9	0.63	1.39	12.8	0.53	0.068	6.02E-05	15	35	0.81	0.37
EKM5	14.5	128	1.1	2.42	19.5	0.82	0.173	1.53E-04	15	80	0.71	0.31
EKM6	25	221	2	4.4	25.7	1.07	0.605	5.35E-04	20	105	0.51	0.24
EKM7	53	469	2.9	6.38	35.6	1.48	1.649	1.46E-03	35	110	0.44	0.20

1. Operating Voltage: 24 Vdc +/- 10%.

2. Maximum backlash is calculated using worst-case tolerancing, and typical backlash is calculated using statistical tolerancing.



# EKM Motor Connector Pinouts

**Connector Options** – Customer is responsible for cabling. Please reference the information below to select the proper mating connector.

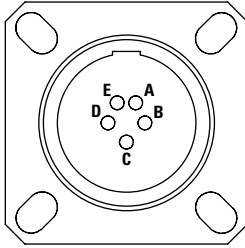

## Power Connector

Manufacturer P/N: D38999/20FB5PN (Amphenol)  
EKM 2X, 3X

Pin	Function	Color
A	Motor A	Blue
B	Motor B	Brown
C	Motor C	Violet
D	Ground	Green/Yellow
E	Filler Pin	N/C

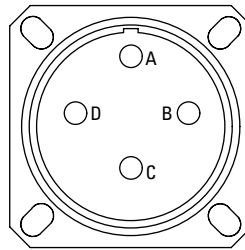

## Power Connector

Manufacturer P/N: D38999/20FC4PN (Amphenol)  
EKM 4X

Pin	Function	Color
A	Motor A	Blue
B	Motor B	Brown
C	Motor C	Violet
D	Ground	Green/Yellow

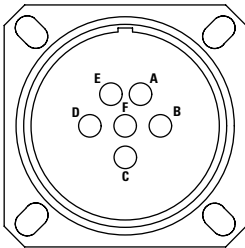

## Power Connector

Manufacturer P/N: D38999/20FE6PN (Amphenol)  
EKM 5X, 6X, 7X

Pin	Function	Color
A	Motor A	Blue
B	Motor B	Brown
C	Motor C	Violet
D	Ground	Green/Yellow
E	Filler Pin	N/C
F	Filler Pin	N/C

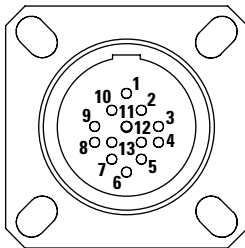

## Feedback Signal Connector

Manufacturer P/N: D38999/20FB35PN (Amphenol)  
EKM 2X, 3X, 4X, 5X, 6X, 7X

Pin	Function	Color
1	Filler Pin	N/C
2	Thermistor	Blue
3	S4: COS (-)	Blue
4	S3: SIN (-)	Black
5	R2: REF (-)	Black/White
6	Thermistor	Black
7	S2: COS (+)	Yellow
8	S1: SIN (+)	Red
9	R1: REF (+)	Red/White
10	Filler Pin	N/C
11	Brake (+)	Black
12	Brake (-)	Black
13	Filler Pin	N/C

# Kollmorgen Solutions



## Self-Help Tools

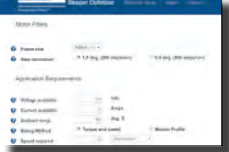
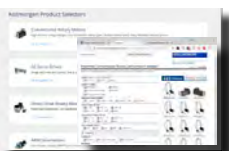
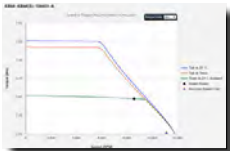

**KOLLMORGEN**

**北京润诚时代科技有限公司**

自动化事业部

地址：北京市朝阳区汤立路218号C 座968室

邮编：100012

电话：010-84450370

传真：010-84450371

网址：[www.runcheng.net](http://www.runcheng.net)

邮箱：[.runcheng\\_emd@sina.com](mailto:.runcheng_emd@sina.com)