

HLR - High Load Rodless Linear Actuator

Parker核心代理商



北京润诚时代科技有限公司

自动化事业部

地址：北京市朝阳区汤立路218号C 座968室

邮编：100012

电话：010-84450370

传真：010-84450371

网址：www.runcheng.net



ENGINEERING YOUR SUCCESS.



WARNING – USER RESPONSIBILITY

FAILURE OR IMPROPER SELECTION OR IMPROPER USE OF THE PRODUCTS DESCRIBED HEREIN OR RELATED ITEMS CAN CAUSE DEATH, PERSONAL INJURY AND PROPERTY DAMAGE.

- This document and other information from Parker-Hannifin Corporation, its subsidiaries and authorized distributors provide product or system options for further investigation by users having technical expertise.
- The user, through its own analysis and testing, is solely responsible for making the final selection of the system and components and assuring that all performance, endurance, maintenance, safety and warning requirements of the application are met. The user must analyze all aspects of the application, follow applicable industry standards, and follow the information concerning the product in the current product catalog and in any other materials provided from Parker or its subsidiaries or authorized distributors.
- To the extent that Parker or its subsidiaries or authorized distributors provide component or system options based upon data or specifications provided by the user, the user is responsible for determining that such data and specifications are suitable and sufficient for all applications and reasonably foreseeable uses of the components or systems.

Overview	5
Product design	6
Technical Characteristics	8
Dimensions	9
Main dimensions	9
HLR070 carriage A (short)	10
HLR070 carriage B (long).....	10
HLR080 carriage A (short)	11
HLR080 carriage B (long).....	11
Sizing of the Linear actuator	12
Accessories	16
Flange kits.....	16
Toe clamps	17
Nuts	17
External end stops	18
Limit switch.....	19
Grease gun	19
System accessories	20
Connecting shaft	20
Bracket plate.....	21
Cross beam	22
OSP-E20BV.....	23
Sizing of drive trains	24
Order Code	26

Parker Hannifin

The global leader in motion and control technologies

A world class player on a local stage

Global Product Design

Parker Hannifin has more than 40 years experience in the design and manufacturing of drives, controls, motors and mechanical products. With dedicated global product development teams, Parker draws on industry-leading technological leadership and experience from engineering teams in Europe, North America and Asia.

Local Application Expertise

Parker has local engineering resources committed to adapting and applying our current products and technologies to best fit our customers' needs.

Manufacturing to Meet Our Customers' Needs

Parker is committed to meeting the increasing service demands that our customers require to succeed in the global industrial market. Parker's manufacturing teams seek continuous improvement through the implementation of lean manufacturing methods throughout the process. We measure ourselves on meeting our customers' expectations of quality and delivery, not just our own. In order to meet these expectations, Parker operates and continues to invest in our manufacturing facilities in Europe, North America and Asia.

Electromechanical Worldwide Manufacturing Locations

Europe

Littlehampton, United Kingdom
Dijon, France
Offenburg, Germany
Filderstadt, Germany
Milan, Italy

Asia

Wuxi, China
Jangan, Korea
Chennai, India

North America

Rohnert Park, California
Irwin, Pennsylvania
Charlotte, North Carolina
New Ulm, Minnesota



Offenburg, Germany

Local Manufacturing and Support in Europe

Parker provides sales assistance and local technical support through a network of dedicated sales teams and authorized technical distributors throughout Europe.

For contact information, please refer to the Sales Offices on the back cover of this document or visit www.parker.com



Milan, Italy



Littlehampton, UK



Filderstadt, Germany



Dijon, France

High Load Rodless Linear Actuator - HLR

Overview

Description

HLR is a linear actuator specially designed for the use in OEM applications.

The HLR is a belt driven/ linear guided drive system offering a very high load capacity with an extremely small form factor.

Its compact outer dimensions and a variety of stroke steps make it ideal for a wide range of automation applications.

With its technical data, the HLR family meets the requirements in industrial applications.

Combined with a wide choice of accessories it offers a very quick and easy way to build multi-axis solutions.

The predefined drive trains simplify the sizing and selection process and reduce development time.

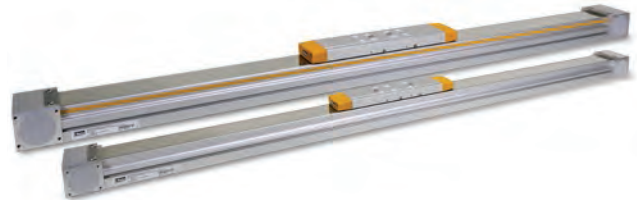

Features

- Compact outside dimensions of 69 x 64 mm and 82 x 76.5 mm
- Rigid aluminum extrusion profile for self-supporting solutions
- High load capacity up to 3847 N (based on a theoretical lifetime of 8.000 km)
- High thrust force up to 900 N
- Motor can be mounted on four sides for highest flexibility
- Acceleration up to 50 m/s²
- Velocity up to 5 m/s
- Last generation linear guide and timing belt for minimised noise emission
- Stainless steel cover as standard for the use in harsh environment
- Easy accessible lubrication bore for reduced maintenance effort
- Extreme straight movement over the complete stroke for building up reliable multi-axis solutions
- High repeatability for highest customer requirements.

Technical Characteristics - Overview

Actuator size	HLR070	HLR080
Drive	Belt drive	
Guiding System	Linear guide	
Width x Height [mm]	69x64	82x76.5
Max. normal load Fz [N]	3847	
Max. thrust force Fx [N]	500	900
Repeatability [mm]	±0.05	
Max. velocity [m/s]	5	
Max. acceleration [m/s ²]	50	
Max. travel length [mm]	2500	3500
Distance [mm/rev]	105	125
Conformity	2011/65/EG: ROHS compliant	
	 RoHS	
Protection class	IP40	

Application

- Material handling and feed systems
- Packaging machines
- General-purpose applications

Product design

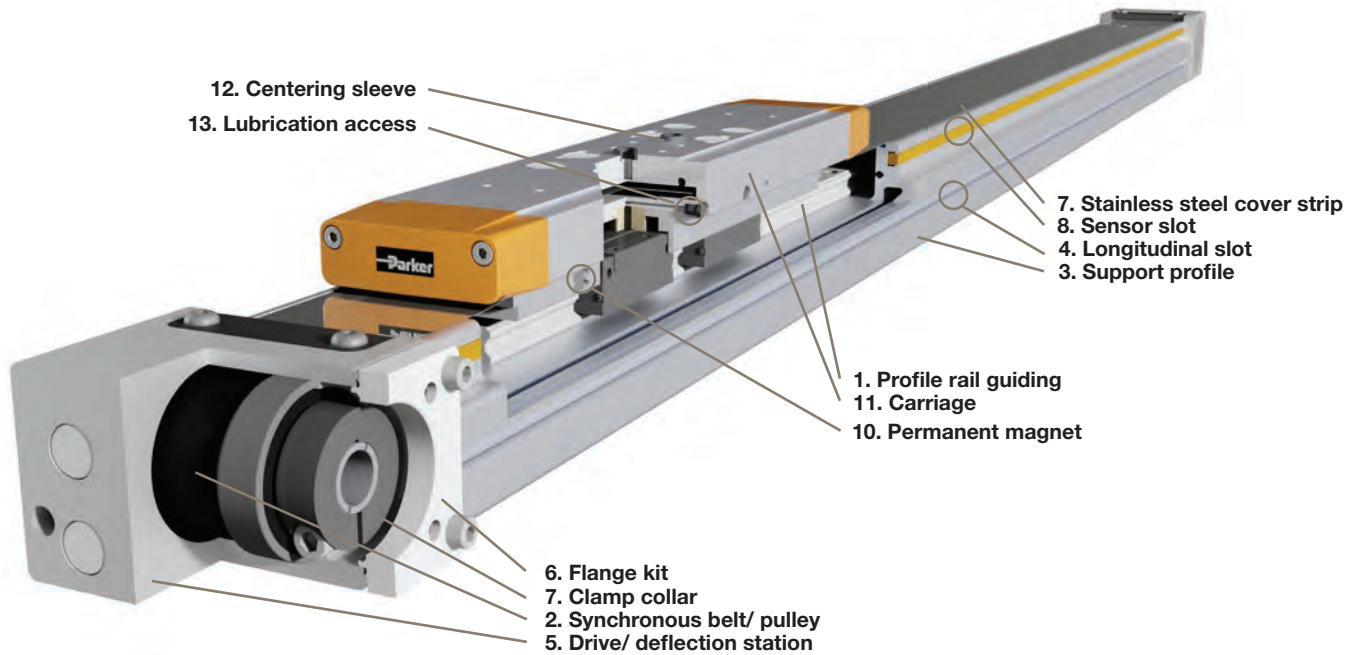

Profile rail guiding (1)

The integrated square rail guide ensures precise and backlash-free linear motion with constant running characteristics and simultaneously high load capacity and travel speed. In conjunction with the synchronous belt (2) and the synchronized pulleys, high feed forces, high repeatability and smoothness are achieved.

Support profile (3)

A lightweight, compact and self-supporting aluminium profile with one longitudinal groove (4) at each side and two at the bottom, which can be used for mounting the linear actuator or other mechanical components.

Drive/ deflection stations (5)

The symmetrically designed drive and deflection stations allow flexible mounting of the drive on each side of the linear actuator. With the optionally available flange kits (6), the drive can be moved to the other station or side at any time by the customer.

The clamping point (7) integrated directly in the drive station enables a direct and very compact connection of the drive to the linear actuator.

Stainless steel cover strip (8)

The stainless steel cover embedded in the support profile is reliably held in place by the magnetic strips integrated in the carrier profile and protects the internal guide against coarse contamination from the outside.

Sensor slot (9)

The sensor slots integrated in the profile on both sides enable the integration of several proximity sensors. These can be attached directly to the support profile at any position and without protruding edges. The sensors are actuated by the permanent magnets (10) integrated in the carriage on both sides. The cables of the sensors can be routed along the linear actuator with the aid of the yellow cover strips.

Carriage (11)

The carriage is available in two standard lengths for each frame size and has several mounting threads for fastening loads. In conjunction with the optionally available toe clamps, the mounting threads allow a cost-effective realisation of a multi-axis system.

The centering sleeves (12) integrated as standard in the carriage allow fast and precise alignment of the load on the carriage.

For relubrication of the internal guide, the carriage has several lubrication accesses (13). These are accessible from both sides of the carriage, making maintenance easier.

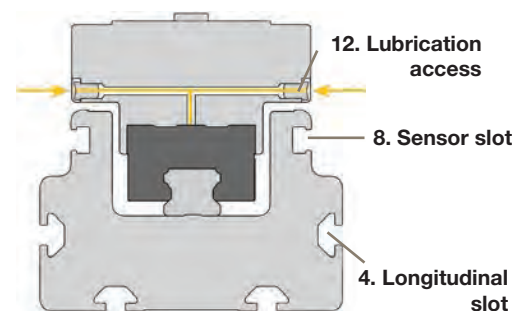

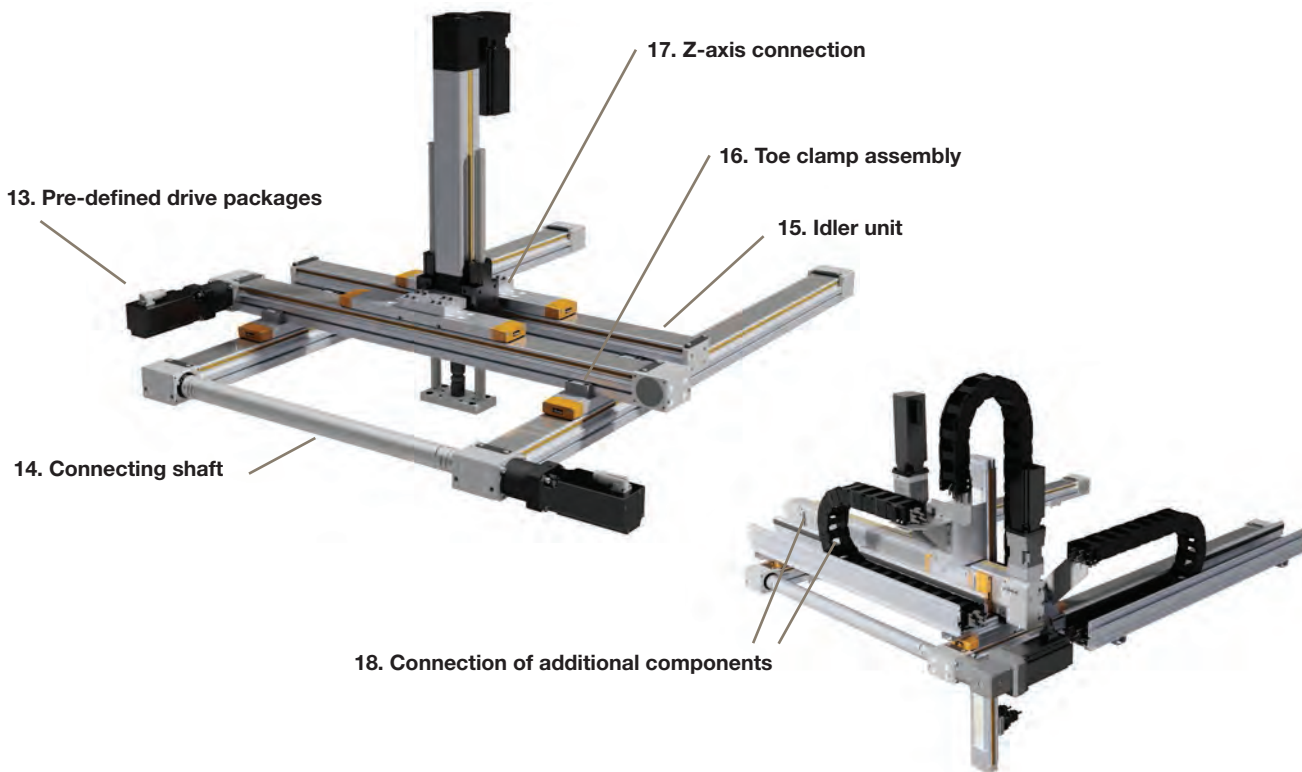

In addition to the two sizes of HLR linear actuators, Parker offers an accessory package not only for single-axis applications, but also for complete double or multi-axis systems.

Pre-defined drive packages (13)

Parker Hannifin also offers the complete drive and control packages for a wide range of applications to match the HLR linear actuators. By using the predefined drive packages, consisting of linear actuator, motor, gearbox and servocontroller, a complete drive train can be quickly selected for the desired application.

Double axis applications

The connecting shaft (14) ensures synchronous and very rigid transmission of the drive torque to a second HLE Linear actuator arranged in parallel. This makes dual axis applications very simple and cost-effective to implement. The connecting shaft is optionally available in different lengths, which allows different center distances to be realized.

For very short centre distances or pure support axes, there is the option of a non-driven, idler axis (15). Here the connecting shaft can be

dispensed with and the load can be mounted directly on the carriage of the driven and the idler axes.

Toe clamp assembly (16)

Toe clamps in different lengths are available for mounting the HLR linear actuators. These grip into the longitudinal slots in the profile and offer a quick and convenient method of fastening. Alternatively, the longitudinal slots in the support profile and slot nuts can also be used. With the toe clamps, one or two cross beams can be fastened directly to the carriage of the HLR linear actuators. This means that no additional connection plates are required and the overall height of the multi-axis system is minimised.

Z-axis connection (17)

With the optionally available mounting plates ETH and ETT can be mounted as z-axis in sizes 032 and 050 as well as the OSP-E20BV directly on the carriage of the HLR linear actuators.

The ETH electric thrust cylinders can also be connected with parallel guidance.

Connection of additional components (18)

Connection of further actuators and energy chains, grippers, etc. is easily possible by the customer by means of the longitudinal slots in the support profile or via the mounting threads in the carriage.

Technical Characteristics

Axis size		HLR070	HLR080
Drive type		Toothed belt drive	
Guiding System		Square rail guide	

Principle dimensions

Axis cross section incl. carriage (width x height)	[mm ²]	69 x 64	82 x 76.5
Max. stroke ¹⁾	[mm]	2500	3500
Carriage A (Standard)	[mm]	372	458
Carriage B (Extended)	[mm]	412	510
Zero stroke with carriage A	[mm]	262	330
Zero stroke with carriage B	[mm]	302	382

Velocity & acceleration

Max. travel speed	[m/s]	5	
Max. acceleration	[m/s ²]	50	

Loads & life times ²⁾

Max. drive torque	[Nm]	8.3	18
Idling torque M_0 ³⁾	[Nm]	0.35	0.55
Max. Thrust force $F_{x,max}$ ⁴⁾	[N]	500	900
Max. Lateral force (Carriage A / Carriage B) $F_{y,max}$	[N]	2 628 / 3 847	3847
Max. load force (carriage A / carriage B) $F_{z,max}$	[N]	2 628 / 3 847	
Max. Tilting torque (carriage A / carriage B) $M_{x,max}$	[Nm]	21 / 30	30
Max. pitching torque (Carriage A / Carriage B) $M_{y,max}$	[Nm]	80 / 164	164 / 262
Max. Yaw torque (Carriage A / Carriage B) $M_{z,max}$	[Nm]	80 / 164	164 / 262

Pulley data

Effective circular diameter	[mm]	33.4	39.8
Feed constant per revolution	[mm]	105	125

Weights

Zero stroke weight with carriage A	[kg]	3.3	5.6
Zero stroke weight with carriage B	[kg]	3.6	5.9
Weight of additional length/ stroke (without carriage)	[kg/m]	4.8	6.6
Zero stroke weight of idler axis with carriage A	[kg]	2.3	3.8
Zero stroke weight of idler axis with carriage B	[kg]	2.7	4.3
Weight of additional length/ stroke of idler axis	[kg/m]	4.6	6.3

Accuracy

Repeatability (according to ISO 230-2)	[mm]	±0.05	±0.05
--	------	-------	-------

Area moment of inertia

Area moment of inertia	[10 ⁴ mm ⁴]	15.7	35.1
------------------------	------------------------------------	------	------

Ambient conditions

Ambient temperature	[°C]	-10...+40	
Storage temperature	[°C]	-20...+40	
Humidity (no condensation)		0...95%	
Protection class		IP40	

Mass moment of inertia relative to the drive shaft

Zero stroke with carriage A	[kgmm ²]	314	752
Zero stroke with carriage B	[kgmm ²]	372	829
Additional length/ stroke (without carriage)	[kgmm ² /m]	53	113
Idler axis with carriage A (stroke independent)	[kgmm ²]	240	554
Idler axis with carriage B (stroke independent)	[kgmm ²]	296	625

- ¹⁾ Min. stroke = 100 mm. Available standard strokes see order code
²⁾ Based on a theoretical lifetime of 8.000 km under ideal conditions
³⁾ Relative to the velocity of 100mm/s with tolerance +/-10%
⁴⁾ Thrust force dependent on travel speed, see diagram2

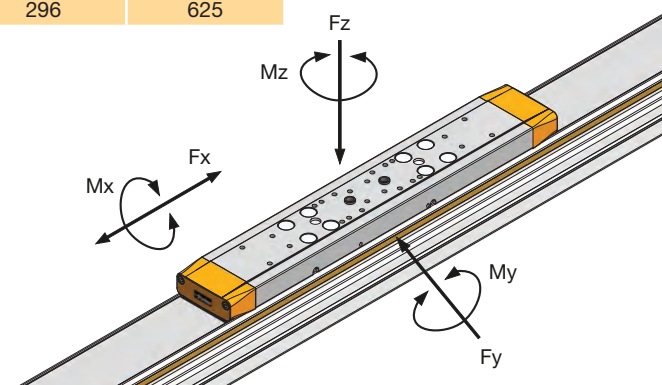

Dimensions

Main dimensions

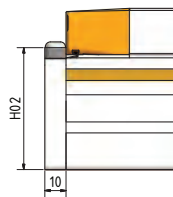
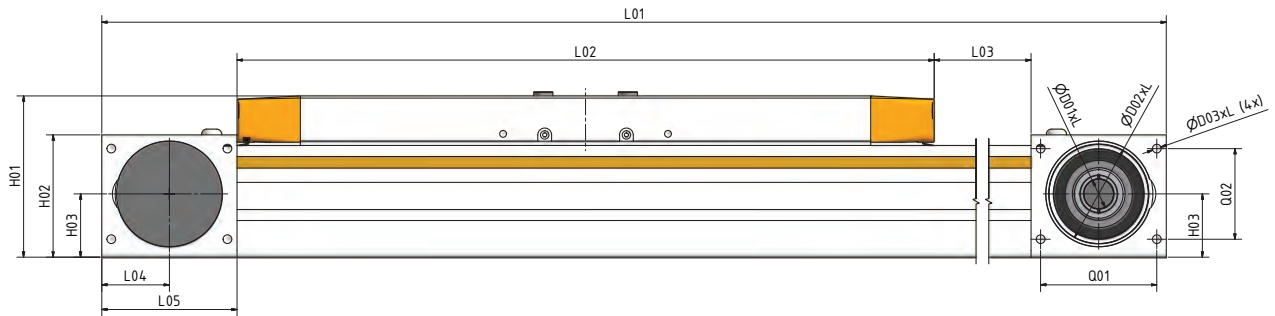

Idler unit ¹⁾

Frame size		HLR070	HLR080
L01	[mm]	L02 + 2 x L05 + stroke	
L02 (carriage A / B)	[mm]	262 / 302	330 / 382
L03	[mm]	Stroke	
L04	[mm]	28	32
L05	[mm]	55	64
H01	[mm]	64	76.5
H02	[mm]	49.3	58
H03	[mm]	22	30
H04	[mm]	20	
H05	[mm]	28.3	35.5
H06	[mm]	²⁾	45
H07	[mm]	44.3	53
B01	[mm]	69	82
B02	[mm]	48.2	63.2
B03	[mm]	30.4	42
B04	[mm]	40	
B05	[mm]	49.8	63.6
B06	[mm]	67	80
Q01	[mm]	42	55
Q02	[mm]	35	43
D01xL	[mm]	10H7 x 10..28	14H7 x 13..34
D02xL	[mm]	40 x 3	47 x 3
D03xL	[mm]	M4 x 12	M5 x 8

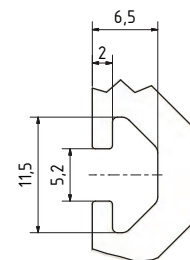
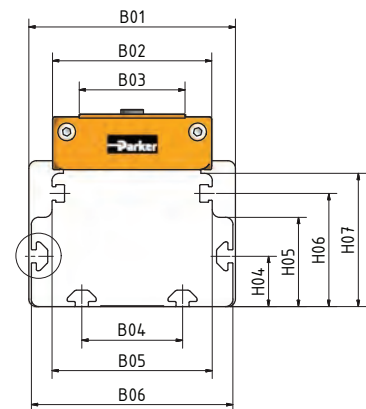

Dimensions in [mm]

¹⁾ Idler axis with end plate on both sides (without drive/ deflection station) for double axis applications with center distances below 200 mm. Example order code for idler axis: **HLR080A1000INNA** (in bold: to be selected)

²⁾ HLR070 has no separate limit switch slot. The limit switches can be mounted in the T-slot.

HLR070 carriage A (short)

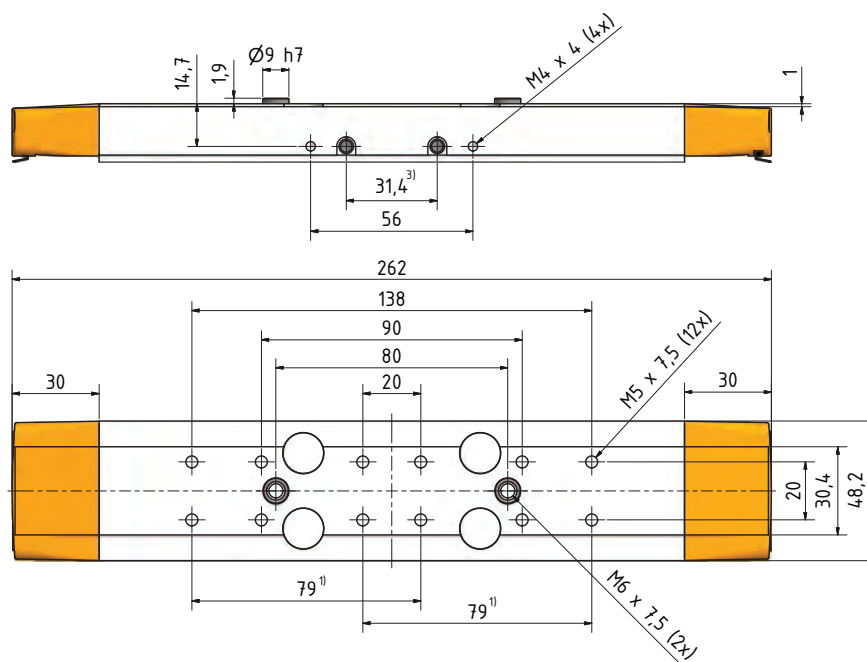

Dimensions in [mm]

HLR070 carriage B (long)

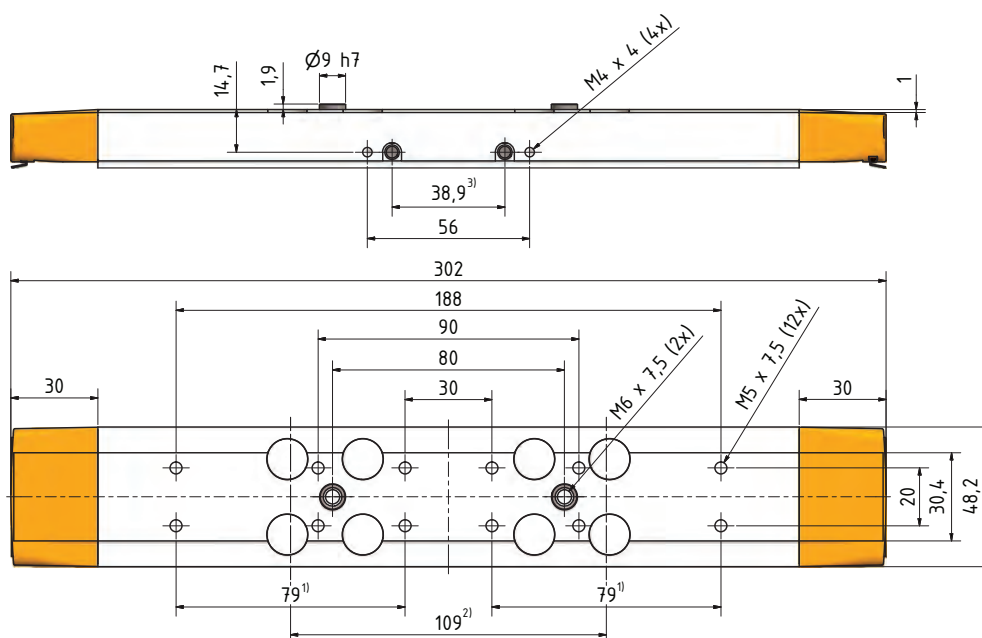

Dimensions in [mm]

¹⁾ Distance for mounting a cross beam (HLR070) directly on the carriage by means of toe clamps

²⁾ Axle distance of double axis suitable for the cross beam for the connection of a Z-axis.

³⁾ Lubrication nipples on both sides of the carriage plate

HLR080 carriage A (short)

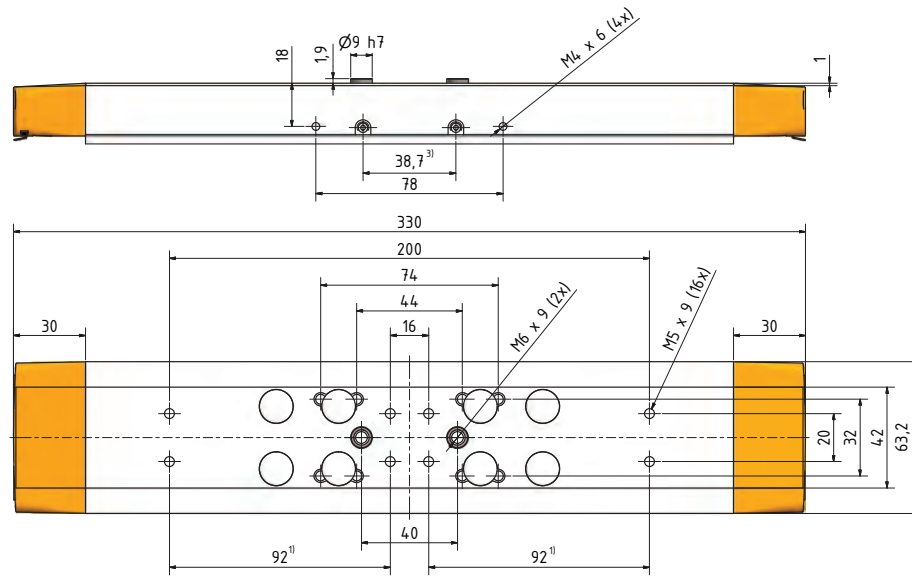

Dimensions in [mm]

HLR080 carriage B (long)

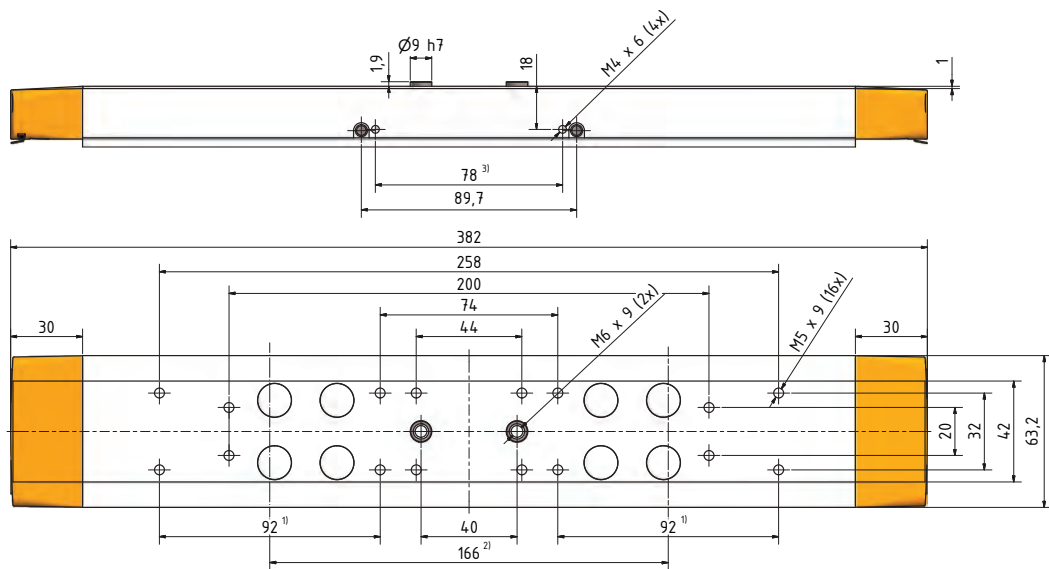

Dimensions in [mm]

- ¹⁾ Distance for mounting a cross axis (HLR080) direct to the carriage by toe clamps
- ²⁾ Axle distance of double axis suitable for the cross beam for the connection of a Z-axis.
- ³⁾ Lubrication nipples on both sides of the carriage plate

Sizing of the Linear actuator

Step 1

Check basic conditions for the use of the HLR axes in the desired application

Before you carry out the detailed sizing of the HLR axis, please first check the general conditions for the use of the axis in the desired application using the technical data on page xx and select one of the HLR sizes:

- Accuracy and ambient conditions (temperature, humidity, protection class)
- Axle cross section and maximum travel range (stroke)
- Maximum velocity and acceleration
- The individual loads on the carriage (Fx, Fy, Fz, Mx, My, Mz)

Step 2

Calculation of the external load and the resulting service life

Load comparison factor f_v

Due to external forces or inertia forces acting on the carriage, the internal guide of the linear actuator is affected by torques around different axes. If different forces and moments occur simultaneously, they are combined in a load comparison factor to determine the service life (Formula 1).

$$f_v = \frac{|F_y|}{F_{y_max}} + \frac{|F_z|}{F_{z_max}} + \frac{|M_x|}{M_{x_max}} + \frac{|M_y|}{M_{y_max}} + \frac{|M_z|}{M_{z_max}} \quad \text{Formula 1}$$

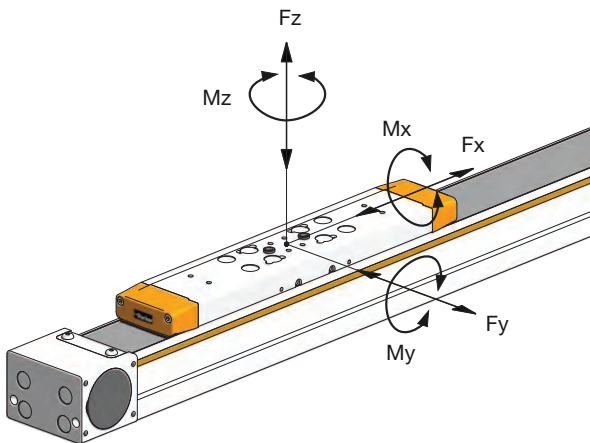

- f_v load comparison factor
- F_y Application-related force in y direction [N]
- F_z Application-related force in z direction [N]
- M_x Application-related torque around the x axis [Nm]
- M_y Application-related torque around the y axis [Nm]
- M_z Application-related torque around the z axis [Nm]
- F_{y_max} Maximum permissible force in y direction [N]
- F_{z_max} Maximum permissible force in z direction [N]
- M_{x_max} Maximum permissible torque around the x axis [Nm]
- M_{y_max} Maximum permissible torque around the y axis [Nm]
- M_{z_max} Maximum permissible torque around the z axis [Nm]

Note: The maximum permissible load characteristics are those specified in the technical data for Fx/y/z and Mx/y/z and must not be exceeded.

When calculating the moments around the x and y axes, observe the force application height HF of the internal guide. Example for the calculation of the torque around the x axis (Formula 2).

$$M_x = F_y * (HF + H_x) \quad \text{Formula 2}$$

- HF Force application height of the guide [mm]
- H_x Force application height of the carriage [mm]

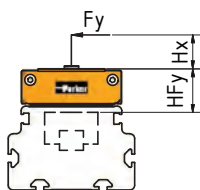

Axis size		HLR070	HLR080
Force application height HF	[mm]	20.8	27.5

Note: The closer the center of gravity of the load is to the center of the rotor plate, the lower are the torque loads around the axes x, y and z, and the higher is the life of the axis. A double axis can be used to compensate for the torque load in the case of heavily cantilevered load connections.

Nominal lifetime L

Now determine the nominal service life ¹ (diagram 1) using the previously calculated load comparison factor f_v .

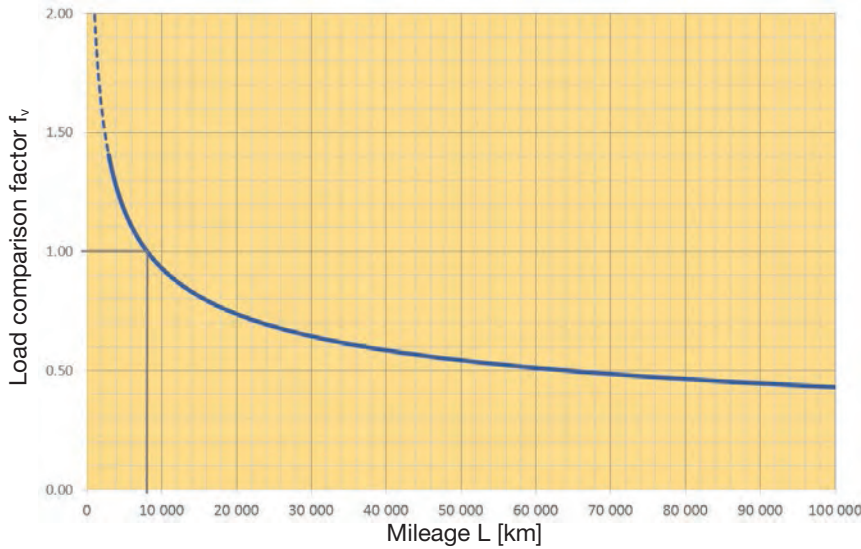

The load comparison factor f_v refers to the nominal service life reference point of 8000 km. With a load of a $f_v < 1$, higher mileages can be reached.

Example: With a load comparison factor of $f_v = 0.5$, the nominal service life is 60,000 km.

Diagram 1: Nominal service life dependence on the load comparison factor

Real service life L_{fw}

The nominal service life L does not take into account increased speeds, inadequate lubrication, shocks or vibrations. These influences can be approximately taken into account by means of the operating coefficient f_w and thus the actual service life can be calculated approximately (formula 3).

$$L_{fw} = \frac{L}{f_w^3} \quad \text{Formula 3}$$

L nominal service life [km] (Diagram 1)
 L_{fw} Service life respecting the operating coefficient [km]
 f_w Operating coefficient

Load type	Velocity [m/s]	Application factor f_w
No shocks/vibrations	< 0.25	1.0 - 1.2
Usual loads	< 1	1.2 - 1.5
Minor shocks	< 2	1.5 - 2.0
Increased shocks/vibrations	> 2	2.0 - 3.5
plus for double axes	-	1.2

¹⁾ Theoretical service life under ideal conditions of use: no shocks and vibrations, no impermissible deflection and tensioning of the axis, compliance with the lubrication intervals.

Calculation of the maximum thrust force

The force acting on the carriage in the x-direction must not exceed the permissible thrust force dependent on the travel speed ¹⁾. Determine the maximum occurring thrust force F_{x_ges} . This must not exceed the thrust force $F_{x_max}(v)$ (diagram 2). If your application has different thrust forces at different travel speeds, each case must be considered separately.

$$F_{x_ges} = F_{x_ext} + F_{x_a} + F_{x_H} = F_{x_ext} + (m_{ext} * a) + (m_{ext} * 9,81m/s^2 * \sin\beta)$$

Formula 4

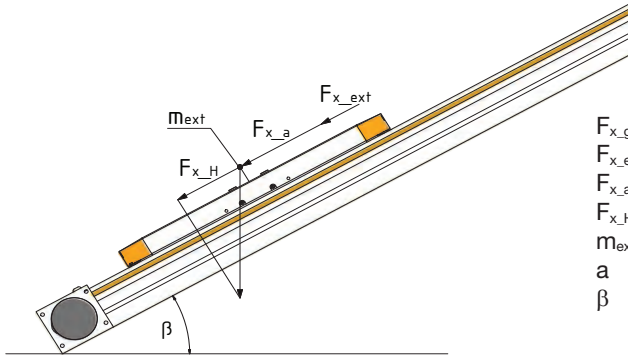

- F_{x_ges} Total thrust force in x direction [N]
- F_{x_ext} Application-dependent thrust force in x direction [N]
- F_{x_a} Application-dependent acceleration force in x direction [N]
- F_{x_H} Downhill force in x direction [N]
- m_{ext} External total load to the carriage [kg]
- a Acceleration [m/s²]
- β Angle of inclination of the axis relative to the horizontal [rad]

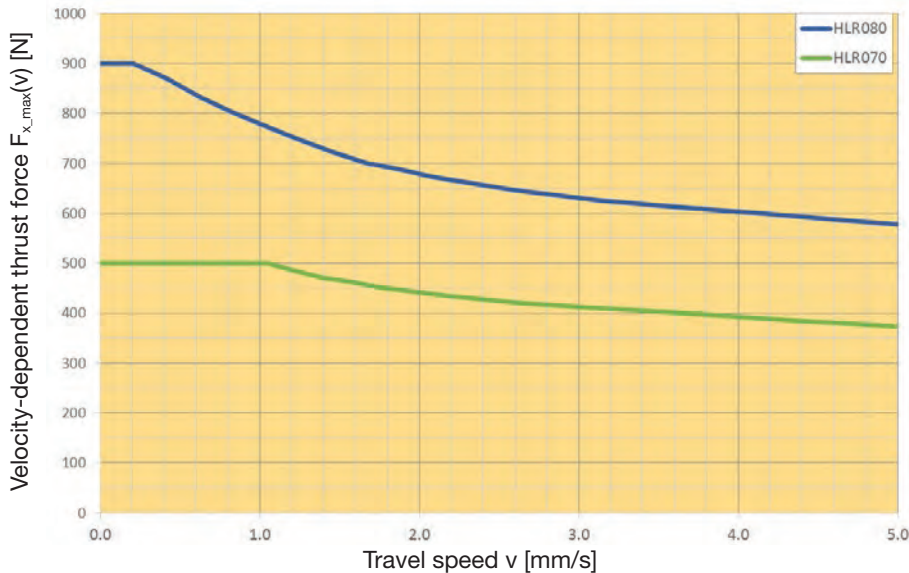

Diagram 2: Velocity-dependent thrust force $F_{x_max}(v)$

Calculation of the required drive torque and the drive speed

To select the correct drive train, calculate the required motor drive torque (formula 5 and 6) and drive speed (formula 7) for your application. The drive torques must be calculated for all segments of the application cycle (represented by index "j") The peak torque of the motor must exceed the maximum drive torque (formula 5). The nominal torque of the motor must exceed the calculated effective torque (formula 6). Provide appropriate safety margins for the drive dimensioning.

$$M_{Aj} = M_{Bj} + M_{Lj} \quad \text{Formula 5}$$

$$M_{Bj} = \left(\left((J_0 + J_{Hub} * Hub) \right) + \left(m_{ext} * \frac{\emptyset Dz^2}{4} \right) \right) * \frac{1}{i_G^2 * \eta_G} + J_G + J_M \Big) * \frac{2*a}{\emptyset Dz} * 10^{-3} \quad \text{Formula 5.1}$$

$$M_{Lj} = M_0 + M_{ext} + M_H = M_0 + \left(\left(F_{x_ext} + \left(m_{ext} * 9,81 \frac{m}{s^2} * \sin\beta \right) \right) * \frac{\emptyset Dz}{2} * 10^{-3} \right) * \frac{1}{i_G * \eta_G} \quad \text{Formula 5.2}$$

¹⁾ The maximum permissible thrust force must not even be exceeded during the acceleration phase.

$$M_{eff} = \sqrt{\frac{1}{t_{total}} * (M_{A1} * t_{B1} + M_{L1} * t_{L1} + \dots)}$$

Formula 6

$$n_A = \frac{v}{k_s/U} * i_G * 6 * 10^4$$

Formula 5

M_{Aj}	Maximum drive torque of the motor [Nm]
M_{Bj}	Application-related acceleration torque (without MLj) [Nm]
M_{Lj}	Application-related motor torque with linear motion [Nm]
M_0	Idle torque of the HLR axis [Nm] (please refer to technical data)
M_{ext}	Application-related load torque due to F_{x_ext} [Nm]
M_H	Application-related load torque due to downhill force [Nm]
M_{eff}	Motor effective torque [Nm]
J_0	Mass moment of inertia with zero stroke [kgmm ²] (please refer to technical data)
J_{stroke}	Mass moment of inertia per mm stroke [kgmm ²] (please refer to technical data)
Stroke	Stroke of the Linear actuator [m]
i_G	Gearbox ratio
η_G	Efficiency of the gearbox (see gearbox manufacturer specifications)
J_G	Mass moment of inertia of the gearbox [kgmm ²] (see gearbox manufacturer specifications)
J_M	Mass moment of inertia of the motor [kgmm ²] (please refer to motor manufacturer specifications)
m_{ext}	External total load to the carriage [kg]
\varnothing_{DZ}	Effective circular diameter of the pulley [mm] (please refer to technical data)
a	acceleration [m/s ²]
F_{x_ext}	Application-related thrust force in x direction [N]
t_{total}	Total cycle time [s]
$t_{B/L}$	Timing components in the cycle (acceleration/deceleration or constant travel) [s]
n_A	Required drive speed of the motor [1/min]
v	Travel speed [m/s]
k_s/U	Feed constant per revolution [mm] (please refer to technical data)

Determine maximum permissible support distances

For unsupported applications, the maximum permissible force F_z depends on the support distance L_s ¹⁾. In order to prevent an inadmissible deflection of the axis, the axis must be fastened to several support points depending on length and load.

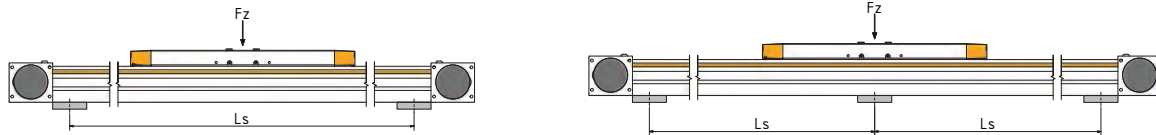

F_{z_max} Application-related force in z direction [N]
 L_s Support distance [mm]

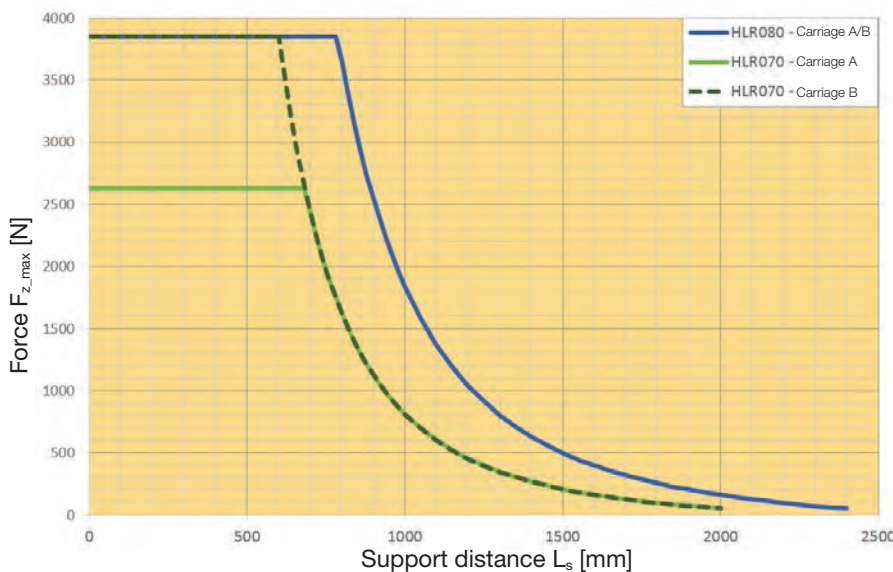

Diagram 3: Permissible support distances

¹⁾ The support profile must be firmly clamped on both sides at all support points, for example by toe clamps (see accessories/toe clamps). If the permissible support distances are adhered to, the deflection of the carrier profile is < 0.5 mm.

Accessories

Flange kits

For the connection of Parker standard gears PE2/PE3. Flange kits consisting of gear flange, clamp collar and fixation screws. Can be mounted on all four sides of the driven HLR linear actuator.

HLR Size		HLR070	HLR080
Gear size		PE2	PE3
Part Number		0232.037	0242.037
L01	[mm]	56	64
L02	[mm]	28	32
H01 ¹⁾	[mm]	44	58
H02 ²⁾	[mm]	49.3	58
H03	[mm]	22	30
ØD01 x L ³⁾	[mm]	10H7 x 17...34	14H7 x 21...40
ØD02 x L ⁴⁾	[mm]	26 x 5	40 x 7
ØD03	[mm]	34	52
ØD04	[mm]	47	61
ØD05 ⁵⁾	[mm]	4.5	5.5

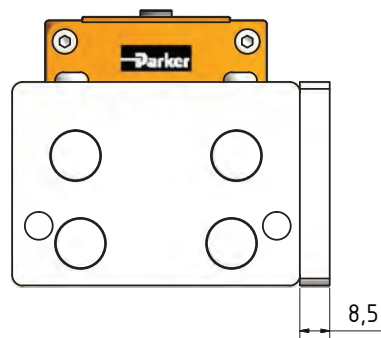
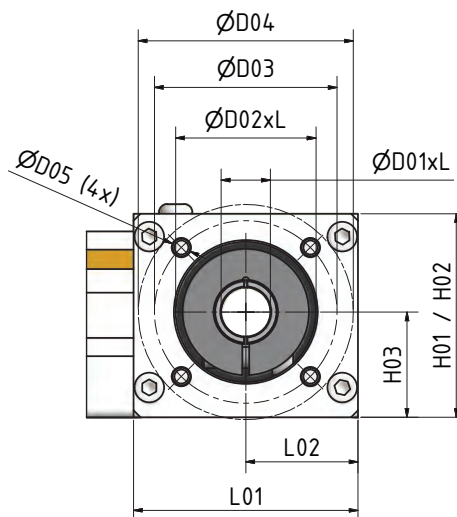

Dimensions in [mm]

¹⁾ Flange height

²⁾ Drive station height

³⁾ Shaft diameter x shaft length

⁴⁾ Pilot diameter x pilot depth

⁵⁾ Through hole for connection flange with gear

Toe clamps

Frame size	HLR070 / HLR080			
Part No.:		0232.901-01 ¹⁾	0232.901-02 ²⁾	0232.901-03
Qty	[Pcs.]	4	4	4
B01	[mm]	67 / 80		
B02	[mm]	79 / 92		
B03	[mm]	91 / 104		
L01	[mm]	20	32	40
L02	[mm]	30	44	52
L03	[mm]	15		
H01	[mm]	19.9		
H02	[mm]	5.4		
ØD01	[mm]	5.5		
ØD02	[mm]	10		

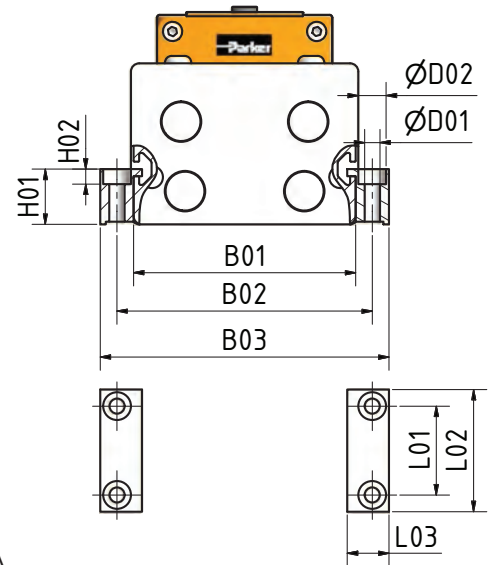

- ¹⁾ Toe clamps for mounting a cross axis directly to the carriage of the HLR070 (carriage A and B) or to the carriage of HLR080 (carriage A)
²⁾ Toe clamps for mounting a cross axis directly to the carriage of the HLR080 (carriage B)

Note: Positioning of the toe clamps and limit switches at the same position on the support profile is not possible with the HLR070 axis. It is possible to position the toe clamps along the limit switch line.

Nuts

Part No.	0232.902
Qty	[Pcs.] 10

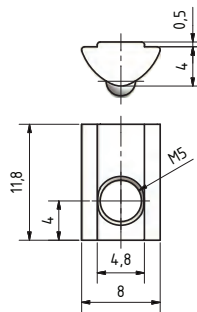

Dimensions in [mm]

External end stops

Functions and advantages

The external end stops can be variably positioned along the support profile and are suitable for limiting the stroke of the HLR axis to protect adjacent machine parts.

Note:

The external end stops are no safety devices, they are not designed to safely decelerate the maximum possible impact energy of the HLR axis. In the event of an unbraked impact against the external or internal end stops of the HLR axis, parts of the axis may be irreparably damaged.

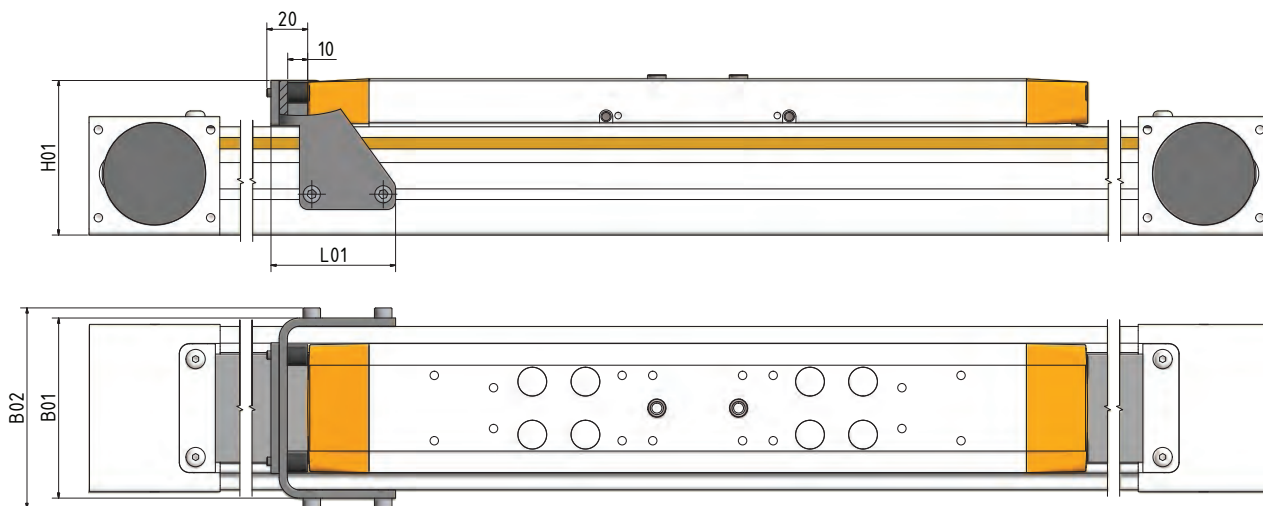

Frame size		HLR070	HLR 080
Part No.:		0232.036	0242.036
Qty	[Pcs.]	1	1
L01	[mm]	56	63
H01 ¹⁾	[mm]	64	76.7
B01	[mm]	75.2	88.2
B02	[mm]	85.2	98.2

Including fixing material in stainless steel

¹⁾ Flush with the carriage plate

Limit switch

The limit switches for position determination can be mounted in the longitudinal slots of the support profile and can be countersunk directly into the profile, so there are no interfering edges. The permanent magnets integrated on both sides of the carriage actuate the sensors. Suitable sensors are optionally available.

Magnetic cylinder sensors

Type	Function	LED	Logic	Cable	Continuous current	Current consumption	Power supply	Switching frequency	compatible with PSD				
P8S-GPFLX	N.O.	yes	PNP	3 m	max. 100 mA	max. 10 mA	10-30 VDC	1 kHz	yes				
P8S-GNFLX			NPN						no				
P8S-GPSHX			PNP	0.3 m cable with M8 connector					yes				
P8S-GNSHX			NPN						no				
P8S-GQFLX	N.C.	yes	PNP	3 m					max. 100 mA	max. 10 mA	10-30 VDC	1 kHz	yes
P8S-GMFLX			NPN	no									
P8S-GQSHX			PNP	0.3 m cable with M8 connector									yes
P8S-GMSHX			NPN	no									

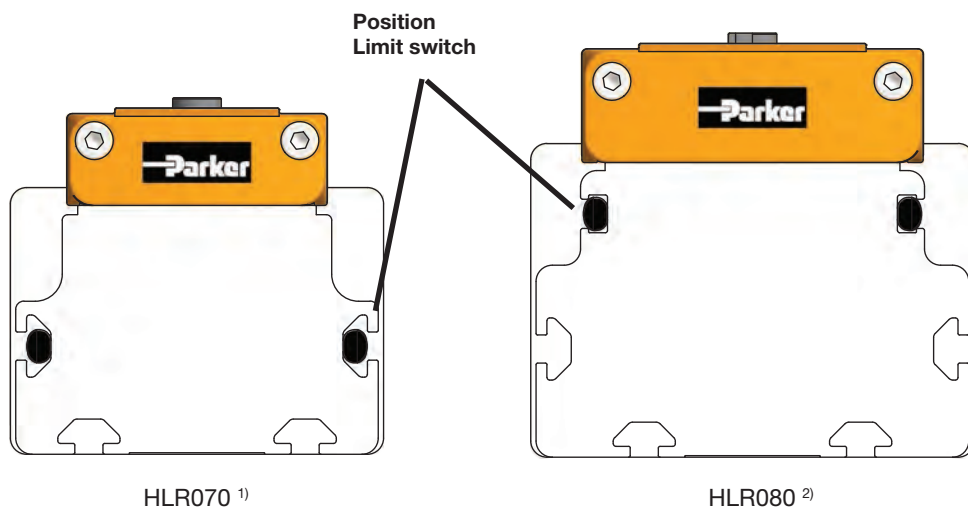

¹⁾ HLR070: Positioning of the toe clamps and limit switches at the same position on the support profile is not possible. It is possible to position the toe clamps along the limit switch line.

²⁾ HLR080: The limit switch cable can be lowered/fixated directly under the yellow cover.

Grease gun

To relubricate ¹⁾ the HLR axis we recommend:

- the lubricant type grease: Klueberplex BEM 34-132
- and the one-handed lubrication press with nozzle attachment type D1a4 (DIN3405)
- The one-handed grease gun with approx. 100 ml capacity, unfilled, including nozzle attachment is available as an accessory
- Part No.: 180-006072



¹⁾ In order to reach the calculated service life, the HLR axis must be lubricated regularly (for lubrication intervals see HLR manual). Independent from the mileage, each axis must be lubricated after 12 months according to the instructions in the manual.

System accessories

Connecting shaft

The connecting shaft is used to transmit the torque of a drive to a second actuator arranged in parallel. Due to the stiffness of the shaft, the drive torque can be transmitted almost synchronously to both linear actuators, even in dynamic applications. This enables a simple design of a very stiff double-axis system.

Note: To prevent an impermissible load on the guide, a connecting shaft is required for double axis systems with centre distances of more than 200 mm.

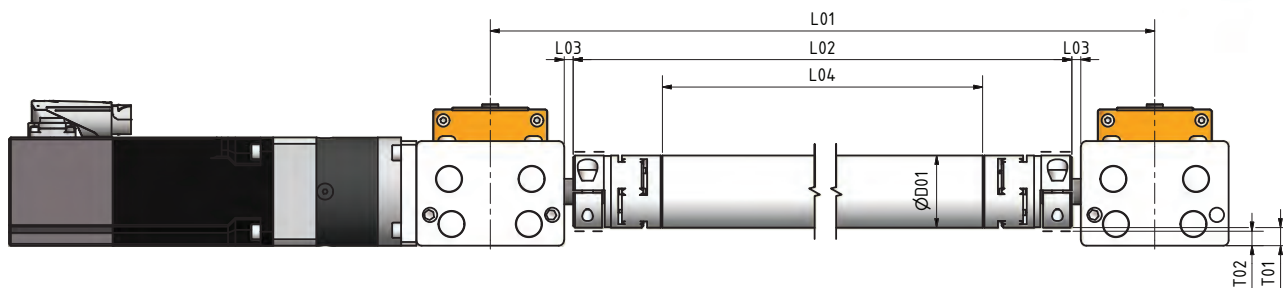
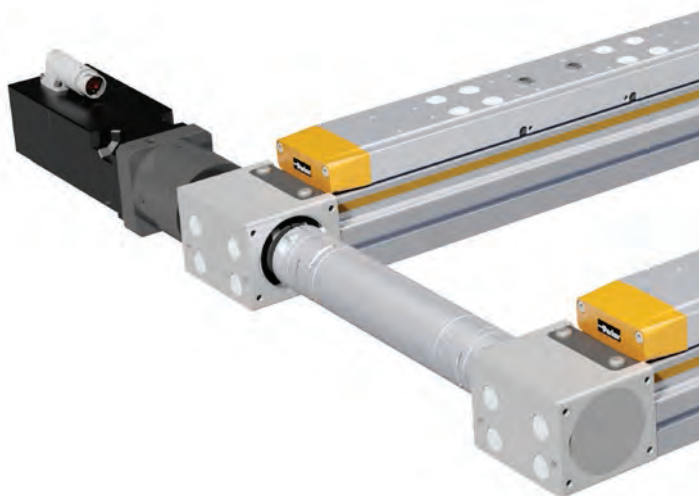

Frame size		HLR070	HLR 080
L01	[mm]	Center distances of 250 to 700 mm in 50 mm steps preferred lengths: 300/400/500/600 mm	
L02	[mm]	L01 - 92	
L03	[mm]	11.5	5
L04	[mm]	L01 - 190	
ØD01	[mm]	40	
T01 ¹⁾	[mm]	2	10
T02 ³⁾	[mm]	-1	7
Moment of inertia zero length	[kgmm ²]	114	207
Moment of inertia length-dependent (for length L04)	[kgmm ² /m]	263	372
Part Number		HLR070	HLR 080
Connecting shaft L01 = 250 mm		0232.910-0250	0242.910-0250
Connecting shaft L01 = 300 mm		0232.910-0300	0242.910-0300
Connecting shaft L01 = 350 mm		0232.910-0350	0242.910-0350
Connecting shaft L01 = 400 mm		0232.910-0400	0242.910-0400
Connecting shaft L01 = 450 mm		0232.910-0450	0242.910-0450
Connecting shaft L01 = 500 mm		0232.910-0400	0242.910-0500
Connecting shaft L01 = 550 mm		0232.910-0550	0242.910-0550
Connecting shaft L01 = 600 mm		0232.910-0600	0242.910-0600
Connecting shaft L01 = 650 mm		0232.910-0650	0242.910-0650
Connecting shaft L01 = 700 mm		0232.910-0700	0242.910-0700

¹⁾ Distance between external diameter of connecting shaft and underside HLR axis

²⁾ Distance between rotation diameter of fixing screws of the connecting shaft and underside HLR axis. HLR070: Due to the compact design of the HLR axis, the rotation diameter of the clamping screws is below the lower edge of the axis.

Bracket plate

Functions and advantages

- Connection to a z axis ETH032 or ETT032 centrally to the carriage of the HLR axis
- Suitable for standard carriage A and B
- With a stepless adjustment range of 50 mm
- Suitable for the connection of the z axis with or without parallel guide (for parallel guide please refer to ETH catalogue)

Versions

0232.034-01 - for ETH032/ETT032 without parallel guide

0232.034-02 - for ETH032/ETT032 with parallel guide

Note:

Dependent on the total load acting the bracket plate and the bracket plate position, an application-specific rolling torque on the guide of the HLR axis results. The maximum permissible rolling torque (see technical data) must not be exceeded.

Depending on the position of the bracket plate and the load connection, it may not be possible to use the complete stroke of the z axis. Consider the height of the HLR axis.

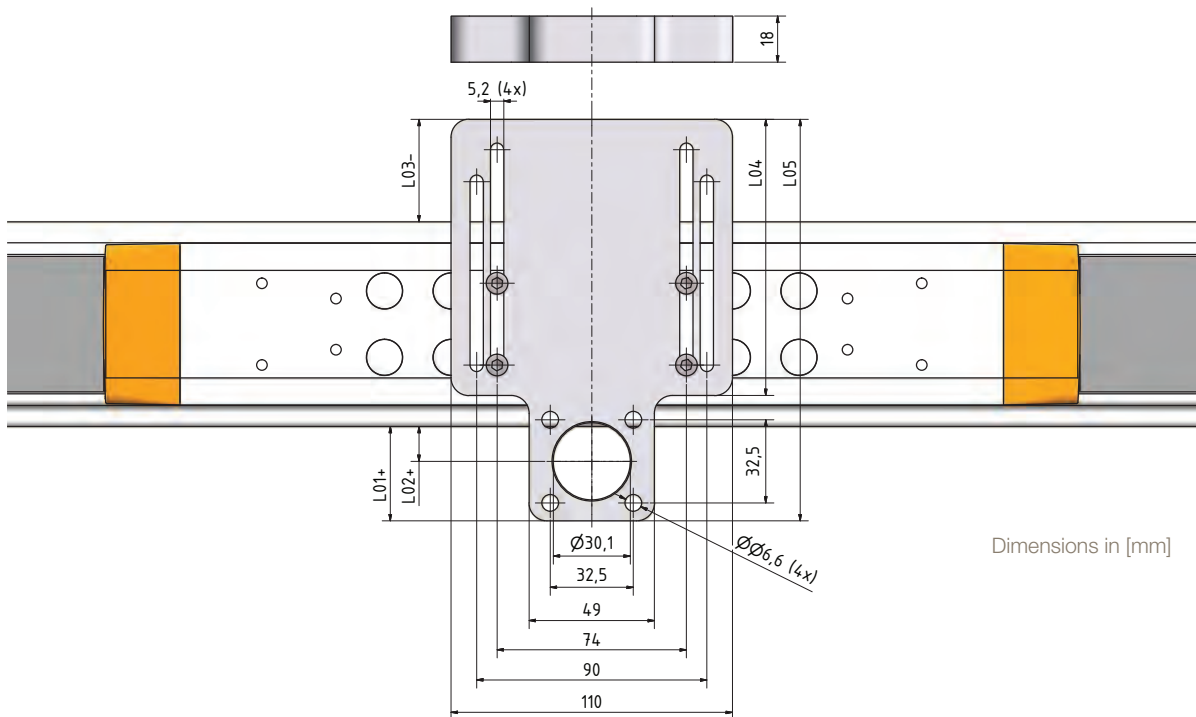

Dimensions in [mm]

Frame size		HLR070		HLR080	
Part No.:		0232.034-01	0232.034-02	0232.034-01	0232.034-02
L01+ ¹⁾	[mm]	37...87	47...87	37...87	47...87
L02+ ¹⁾	[mm]	14...64	24...64	14...64	24...64
L03- ¹⁾	[mm]	53...3	43...3	40...-10	30...-10

Bracket plate including fixing material

¹⁾ Adjustment range of the bracket plate without parallel guide = 50 mm / with parallel guide = 40 mm

Cross beam

Functions and advantages

- Connection of a z-axis ETH/ETT in sizes 032/050 on a HLR double axis for high loads
- Suitable for standard carriage A and B
- Suitable for the connection of the z axis with or without parallel guide (for parallel guide please refer to ETH catalogue)

Versions HLR070

- 0232.035-01 - for ETH032/ETT032 without parallel guide
- 0232.035-02 - for ETH050/ETT050 without parallel guide

Versions HLR080

- 0242.035-01 - for ETH032/ETT032 without parallel guide
- 0242.035-02 - for ETH050/ETT050 without parallel guide
- 0242.035-03 - for ETH032/ETT032 with parallel guide
- 0242.035-04 - for ETH050/ETT050 with parallel guide



Note: The maximum permissible load force of the axes (see technical data) must not be exceeded. Depending on the load applied to the z-axis, it may not be possible to retract the z-axis completely.

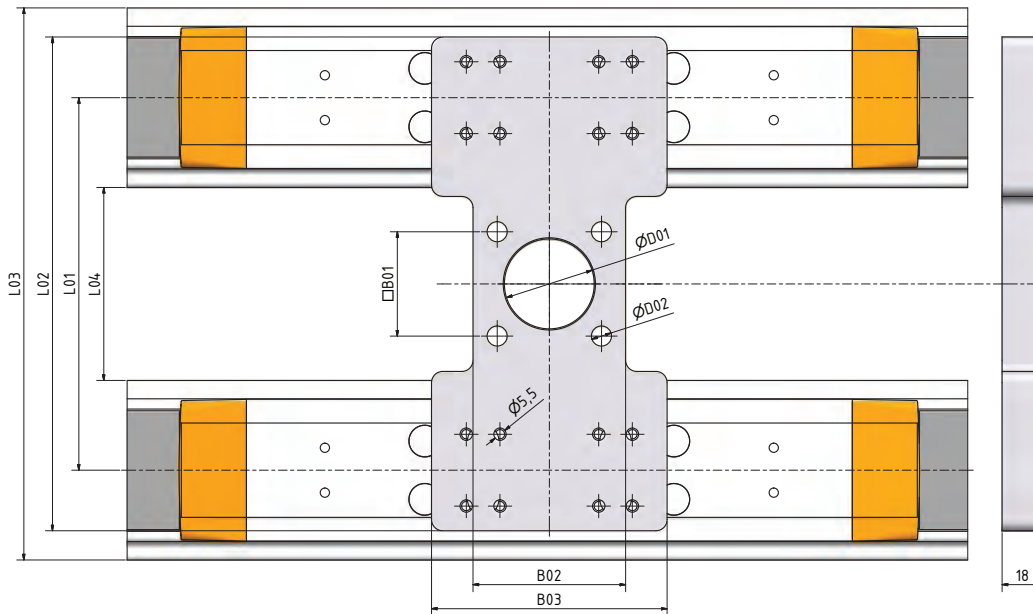

Frame size		HLR070		HLR080			
Part No.:		0232.035-01	0232.035-02	0242.035-01	0242.035-02	0242.035-03	0242.035-04
ØD01	[mm]	30.1	40.1	30.1		40.1	
ØD02	[mm]	6.6	9	6.6		9	
B01	[mm]	32.5	46.5	32.5		46.5	
B02	[mm]	50	105	49		64	
B03	[mm]	50	105	65		105	
L01 ¹⁾	[mm]	109		166			
L02	[mm]	150		220			
L03	[mm]	176		246			

Bracket plate including fixing material

¹⁾ Distance of the double axis results from mounting the double axis as cross axis on the carriage type B

OSP-E20BV

Functions and advantages

- Connection of the z-axis OSP-E20BV, cantilevered on the HLR080 linear axis
- Suitable for standard carriage A and B

Note: The maximum permissible rolling torque of the HLR linear axis (see technical data) must not be exceeded.

Frame size	HLR080
z-axis	OSP-E20BV
Part No.:	0242.034

Bracket plate including fixing material

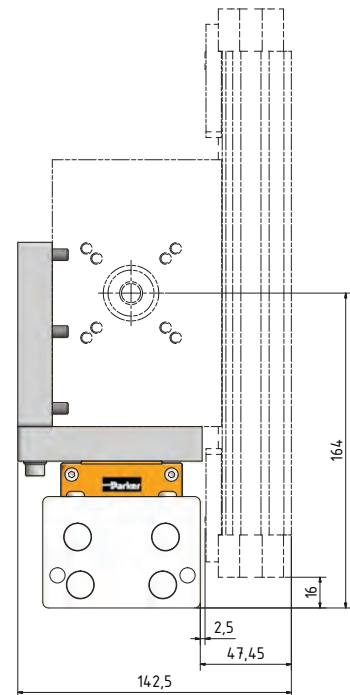
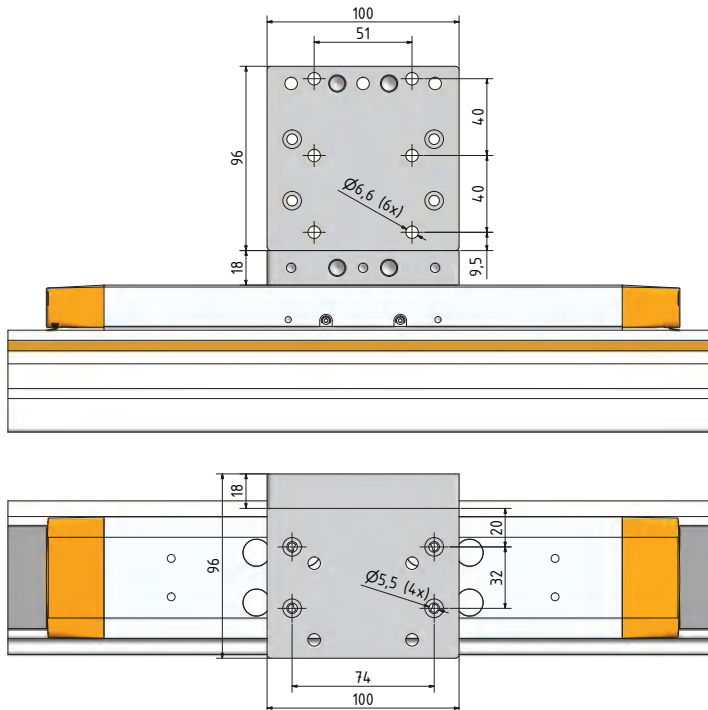

Sizing of drive trains

Predefined drive trains - single axis

Frame size	<div style="border: 1px solid blue; padding: 2px;">Max. load [kg]</div> <div style="border: 1px solid red; padding: 2px; margin-top: 5px;">Max. velocity [m/s]</div> <div style="border: 1px solid green; padding: 2px; margin-top: 5px;">Max. acceleration [m/s²]</div>		Max. Load	Max. Speed	Max. Acceleration	Supply voltage	Lifetime (Carriage A / Carriage B)	Operating coefficient	Linear actuator
			[kg]	[m/s]	[m/s ²]	[V]	[km]		
080		01	10	3.8	25	230	> 43.000 ¹⁾ / >100.000	3.0	HLR080A1200DNN
		02	20	2.4	5	230	> 100.000 / >100.000	2.5	HLR080A1200DNN
		03	50	2.3	10	230	> 5.000 ²⁾ / >13.000 ³⁾	2.5	HLR080A1200DNN
070		04	5	3.3	25	230	> 24.000 ⁴⁾ / >100.000	2.0	HLR070A1200DNN
		05	10	3.3	10	230	> 100.000 / >100.000	2.6	HLR070A1200DNN
		06	25	2	10	230	> 100.000 / >100.000	2.6	HLR070A1200DNN

¹⁾ Reduction of the acceleration to 15 m/s² increases the mileage of the Linear actuator to > 100.000 km

²⁾ Reduction of the acceleration to 2 m/s² increases the mileage of the Linear actuator to > 71.000 km

³⁾ Reduction of the acceleration to 2 m/s² increases the mileage of the Linear actuator to > 100.000 km

⁴⁾ Reduction of the acceleration to 4 m/s² increases the mileage of the Linear actuator to > 100.000 km

Predefined drive trains - Double axis

Frame size	<div style="border: 1px solid blue; padding: 2px;">Max. load [kg]</div> <div style="border: 1px solid red; padding: 2px; margin-top: 5px;">Max. velocity [m/s]</div> <div style="border: 1px solid green; padding: 2px; margin-top: 5px;">Max. acceleration [m/s²]</div>		Max. load	Max. velocity	Max. acceleration	Supply voltage	Lifetime (Carriage A / Carriage B)	Operating coefficient	Linear actuator	
			[kg]	[m/s]	[m/s ²]	[V]	[km]			
080		01	20	3.6	20	230	> 100.000	2.8 x 1.2	HLR080A0800DNN	0242.9
		02	100	2.2	6.5	230	> 11.000 ¹⁾	2.1 x 1.2	HLR080A0800DNN	0242.9
070		03	10	3.3	14	230	> 100.000	2.0 x 1.2	HLR070A0800DNN	0232.9
		04	35	2	8	230	> 100.000	1.2 x 1.2	HLR070A0800DNN	0232.9

¹⁾ Reduction of the acceleration to 2 m/s² increases the mileage of the Linear actuator to > 67.000 km

Boundary conditions of the drive sizing

- Horizontal installation position
- Linear acceleration
- Deceleration = acceleration
- Delta operation Acceleration & deceleration over 100% of the distance
- Ambient temperature = 20°C
- Installation altitude not above 1000m above sea level
- Stall time per cycle 1 second for double axis and 0.2 second for single axis
- Mileage is valid for delta operation In trapezoidal operation with a lower proportion of acceleration and deceleration, the mileage is significantly increased.
- Technical data of the individual components must not be exceeded (e.g. drive torque, ambient conditions, etc.)
- Centre of gravity of the load in the middle, 60 mm (for HLR070) and 80 mm (for HLR080) above the carriage. With double axes load centre of gravity double
- F_y; M_x; M_z = 0
- Load distribution to the double axes 50/50

	Flange kit	Gearboxes	Motor	Servo controller	Braking Resistor
NA	0242.037	PE3-003-16M060/075/14/30	SMH[A]826003714SIZ64S62	PSD1SW1300B1100000	ACB-0005-02
NA	0242.037	PE3-005-16M040/063/11/23	SMH[A]60601,4811SIZ64S62	PSD1SW1200B1100000	--
NA	0242.037	PE3-005-16M060/075/14/30	SMH[A]826003714SIZ64S62	PSD1SW1300B1100000	ACB-0005-02
NA	0232.037	PE2-003-16M040/063/11/23	SMH[A]60601,4811SIZ64S62	PSD1SW1200B1100000	--
NA	0232.037	PE2-003-16M040/063/11/23	SMH[A]60601,4811SIZ64S62	PSD1SW1200B1100000	--
NA	0232.037	PE2-005-16M040/063/11/23	SMH[A]60601,4811SIZ64S62	PSD1SW1200B1100000	--

Connecting shaft	Flange kit	Gearboxes	Motor	Servo controller	Braking Resistor
010-0400	0242.037	PE3-003-16M060/075/14/30	SMH[A]826003714SIZ64S62	PSD1SW1300B1100000	ACB-0005-02
010-0400	0242.037	PE3-005-16M060/075/14/30	SMH[A]826003714SIZ64S62	PSD1SW1300B1100000	ACB-0005-02
010-0300	0232.037	PE2-003-16M040/063/11/23	SMH[A]60601,4811SIZ64S62	PSD1SW1200B1100000	--
010-0300	0232.037	PE2-005-16M040/063/11/23	SMH[A]60601,4811SIZ64S62	PSD1SW1200B1100000	--

Order codes:

bold: mandatory so that the package is combinable

blue: to be selected depending on the requirement

Further information about:

PE Garheads www.parker.com/eme/gear

SMH Motors www.parker.com/eme/smh

PSD Drives www.parker.com/eme/psd

Order Code

	1	2	3	4	5	6	7	8	9
Product Code	HLR	080	A	1000	D	N	N	A	Uxx

1 Series	HLR High Load Rodless
2 Frame size	070 Profile size 67 mm 080 Profile size 80 mm
3 Carriage type	A Standard carriage B Extended carriage
4 Stroke	For stroke 100 mm - 500 mm - in steps of 20 mm For stroke 500 mm - 1000 mm - in steps of 50 mm xxxx For stroke >1000 mm - in steps of 100 mm HLR070 up to 2500mm HLR080 up to 3500 mm
5 Drive option	D Driven axis I Idler axis
6 Option	N Standard
7 Option	N Standard
8 Protection class	A IP40, low corrosion version with stainless steel screws
9 Optional	U x x Customized part No.



Parker's Motion & Control Technologies

At Parker, we're guided by a relentless drive to help our customers become more productive and achieve higher levels of profitability by engineering the best systems for their requirements. It means looking at customer applications from many angles to find new ways to create value. Whatever the motion and control technology need, Parker has the experience, breadth of product and global reach to consistently deliver. No company knows more about motion and control technology than Parker. For further info call 00800 27 27 5374



Aerospace

Key Markets

Aftermarket services
Commercial transports
Engines
General & business aviation
Helicopters
Launch vehicles
Military aircraft
Missiles
Power generation
Regional transports
Unmanned aerial vehicles

Key Products

Control systems & actuation products
Engine systems & components
Fluid conveyance systems & components
Fluid metering, delivery & atomization devices
Fuel systems & components
Fuel tank inerting systems
Hydraulic systems & components
Thermal management
Wheels & brakes



Climate Control

Key Markets

Agriculture
Air conditioning
Construction Machinery
Food & beverage
Industrial machinery
Life sciences
Oil & gas
Precision cooling
Process
Refrigeration
Transportation

Key Products

Accumulators
Advanced actuators
CO₂ controls
Electronic controllers
Filter driers
Hand shut-off valves
Heat exchangers
Hose & fittings
Pressure regulating valves
Refrigerant distributors
Safety relief valves
Smart pumps
Solenoid valves
Thermostatic expansion valves



Electromechanical

Key Markets

Aerospace
Factory automation
Life science & medical
Machine tools
Packaging machinery
Paper machinery
Plastics machinery & converting
Primary metals
Semiconductor & electronics
Textile
Wire & cable

Key Products

AC/DC drives & systems
Electric actuators, gantry robots & slides
Electrohydraulic actuation systems
Electromechanical actuation systems
Human machine interface
Linear motors
Stepper motors, servo motors, drives & controls
Structural extrusions



Filtration

Key Markets

Aerospace
Food & beverage
Industrial plant & equipment
Life sciences
Marine
Mobile equipment
Oil & gas
Power generation & renewable energy
Process
Transportation
Water Purification

Key Products

Analytical gas generators
Compressed air filters & dryers
Engine air, coolant, fuel & oil filtration systems
Fluid condition monitoring systems
Hydraulic & lubrication filters
Hydrogen, nitrogen & zero air generators
Instrumentation filters
Membrane & fiber filters
Microfiltration
Sterile air filtration
Water desalination & purification filters & systems



Fluid & Gas Handling

Key Markets

Aerial lift
Agriculture
Bulk chemical handling
Construction machinery
Food & beverage
Fuel & gas delivery
Industrial machinery
Life sciences
Marine
Mining
Mobile
Oil & gas
Renewable energy
Transportation

Key Products

Check valves
Connectors for low pressure fluid conveyance
Deep sea umbilicals
Diagnostic equipment
Hose couplings
Industrial hose
Mooring systems & power cables
PTFE hose & tubing
Quick couplings
Rubber & thermoplastic hose
Tube fittings & adapters
Tubing & plastic fittings



Hydraulics

Key Markets

Aerial lift
Agriculture
Alternative energy
Construction machinery
Forestry
Industrial machinery
Machine tools
Marine
Material handling
Mining
Oil & gas
Power generation
Refuse vehicles
Renewable energy
Truck hydraulics
Turf equipment

Key Products

Accumulators
Cartridge valves
Electrohydraulic actuators
Human machine interfaces
Hybrid drives
Hydraulic cylinders
Hydraulic motors & pumps
Hydraulic systems
Hydraulic valves & controls
Hydrostatic steering
Integrated hydraulic circuits
Power take-offs
Power units
Rotary actuators
Sensors



Pneumatics

Key Markets

Aerospace
Conveyor & material handling
Factory automation
Life science & medical
Machine tools
Packaging machinery
Transportation & automotive

Key Products

Air preparation
Brass fittings & valves
Manifolds
Pneumatic accessories
Pneumatic actuators & grippers
Pneumatic valves & controls
Quick disconnects
Rotary actuators
Rubber & thermoplastic hose & couplings
Structural extrusions
Thermoplastic tubing & fittings
Vacuum generators, cups & sensors



Process Control

Key Markets

Alternative fuels
Biopharmaceuticals
Chemical & refining
Food & beverage
Marine & shipbuilding
Medical & dental
Microelectronics
Nuclear Power
Offshore oil exploration
Oil & gas
Pharmaceuticals
Power generation
Pulp & paper
Steel
Water/wastewater

Key Products

Analytical Instruments
Analytical sample conditioning products & systems
Chemical injection fittings & valves
Fluoropolymer chemical delivery fittings, valves & pumps
High purity gas delivery fittings, valves, regulators & digital flow controllers
Industrial mass flow meters/controllers
Permanent no-weld tube fittings
Precision industrial regulators & flow controllers
Process control double block & bleeds
Process control fittings, valves, regulators & manifold valves



Sealing & Shielding

Key Markets

Aerospace
Chemical processing
Consumer
Fluid power
General Industrial
Information technology
Life sciences
Microelectronics
Military
Oil & gas
Power generation
Renewable energy
Telecommunications
Transportation

Key Products

Dynamic seals
Elastomeric o-rings
Electro-medical instrument design & assembly
EMI shielding
Extruded & precision-cut, fabricated elastomeric seals
High temperature metal seals
Homogeneous & inserted elastomeric shapes
Medical device fabrication & assembly
Metal & plastic retained composite seals
Shielded optical windows
Silicone tubing & extrusions
Thermal management
Vibration dampening

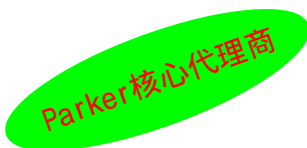

北京润诚时代科技有限公司

自动化事业部

地址：北京市朝阳区汤立路218号C 座968室

邮编：100012

电话：010-84450370

传真：010-84450371

网址：www.runcheng.net

